



I N B O A R D P R O P E L L E R C A T A L O G



Michigan Wheel Marine 





*Michigan Wheel
manufactures propellers
with particular emphasis on
tolerance specifications.*

*Each Propeller meets
exacting tolerances,
and is fully inspected.*

WHO WE ARE

Since 1903, Michigan Wheel Marine has been the world leader in propulsion and marine maneuverability systems.

We are the go-to propeller supplier to custom yacht manufacturers, production boat builders, commercial shipyards and governments around the world. For those that seek to optimize performance and efficiency, Michigan Wheel has the expansive propeller design and analysis capabilities to increase speeds, improve cruising range, and provide exceptional passenger comfort levels.



TABLE OF CONTENTS

Michigan Propellers	04
Pleasure Boat Propellers	06
Sailboat Propellers	10
Mud Boat Propellers	11
Commercial Propellers	12
Federal Propellers	18
Marlin Series	22
"Y" Series	23
"CX" Series	24
"HX" / "X" / Equi-Poise & Equi-Quad	25
HyTorq Propellers	26
MY-T Series	28
Company History	30
Manufacturing Process	32
Propeller Terms & Definitions	34
Inboard Propeller Installation Process	36
Marine Propeller Shaft End Dimensions	37
Prop-It-Right Analysis Form	38

WHAT WE DO

QUALITY.

Michigan Wheel Marine is committed to the pursuit of quality excellence. We have ongoing training for all of our personnel and suppliers.

Engineering support is continually upgraded. Through this effort, we seek to continually reduce product and process variation. Michigan Wheel operates on the philosophy that quality is the cornerstone of economic growth and stability. Therefore, quality is the responsibility of every individual in our organization. With the cooperation and input from our suppliers and customers, we are committed to continuous improvement.

ENGINEERING.

With decades of experience as the Marine Propulsion Industry Leader, the Engineering Department at Michigan Wheel and select Michigan Distributors have the knowledge and experience to suggest propellers for your boat. Our Naval Architects, Engineers, and many of our Distributors are available to review your vessel data and your performance expectations. Specialized proprietary software programs can determine the best propeller match, in size and style, for your boat's engine and gear ratio combination.





FOR THOSE THAT SEEK TO OPTIMIZE PERFORMANCE
AND EFFICIENCY, MICHIGAN WHEEL HAS THE EXPANSIVE
PROPELLER DESIGN AND ANALYSIS CAPABILITIES TO INCREASE
SPEEDS, IMPROVE CRUISING RANGE, AND PROVIDE EXCEPTIONAL
PASSENGER COMFORT LEVELS.

MICHIGAN PROPELLERS



Photo Courtesy of Hatteras Yachts



 **Michigan
propellers**

"X" SERIES

Available Alloys



The "DJX" and "DQX" are evolutions of the classic Dyna-Jet and Dyna-Quad propeller designs, respectively, and are more closely optimized for modern marine craft. "X" Series propellers are the benchmark standard for high quality, performance-oriented propellers.

MICHIGAN PROPELLERS



DJX

Specifications

0.61 E.A.R.
Diameter Range: 12" - 21"
21° of Skew



DQX

Specifications

0.735 E.A.R.
Diameter Range: 17" - 22"
21° of Skew



DQX

Specifications

0.81 E.A.R.
Diameter Range: 23" - 32"
21° of Skew

All "X" Series propellers are designed to efficiently use the higher engine power boating production by modern boat engines, both gas and diesel. With higher blade areas, the "X" propellers can better convert extra power into additional thrust. The increased blade area and refined blade chord distributions help minimize vibration for common high horsepower, limited tip-clearance applications. All "X" Series propellers are manufactured utilizing modern CNC machine finishing technology. This results in high quality propellers meeting stringent tolerance requirements at competitive prices.

Michigan Wheel offers a 4-blade DQX, which will result in smoother operation when compared to a 3-blade DJX. As boat size increases, larger engines will require the DQX to maximize thrust potential. Michigan Wheel also offers a 4-blade DQX with extra blade area (0.81 E.A.R.). This propeller can excel on performance applications where the propulsion system must accommodate various combinations of high engine power, propeller diameter constraints, and high boat speed.

DJX SPECIFICATIONS (0.61 E.A.R.)

DIAMETER		HUB DIMENSIONS (INCHES)			STANDARD TAPER BORE (INCHES)			MAXIMUM BLADE WIDTH (INCHES)	EXPANDED AREA PER BLADE (SQ.IN)	APPROX. NET WEIGHT (LBS.)	*WR ² (LBS.-IN ²)
INCHES	MM	AFT END	FORWARD END	LENGTH	MINIMUM BORE	MAXIMUM BORE	PILOT BORE				
12	305	1-5/8	1-3/4	2-3/8	7/8	1-1/8	7/8	5-7/16	22.7	5	41
13	330	1-5/8	1-7/8	2-3/4	7/8	1-1/8	7/8	6	26.8	6	61
14	356	1-7/8	2	2-3/4	1	1-1/4	1	6-1/2	31	8	90
15	381	1-7/8	2	2-3/4	1	1-1/4	1	6-7/8	35.8	10	126
16	406	2-1/8	2-3/8	3-1/4	1-1/8	1-1/2	1-1/8	7-3/8	40.5	12	172
17	432	2-1/4	2-1/2	3-1/4	1-1/4	1-1/2	1-1/4	7-7/8	45.4	14	232
18	457	2-3/8	2-5/8	3-3/4	1-1/4	1-3/4	1-1/4	8-5/16	51.3	16	307
19	483	2-3/8	2-5/8	3-3/4	1-1/4	1-3/4	1-1/4	8-3/4	57.3	19	401
20	508	2-3/8	2-5/8	3-3/4	1-1/4	2	1-1/4	9-1/4	63.8	21	516
21	533	2-3/4	3	4-1/8	1-3/8	2	1-3/8	9-3/4	69.9	26	660

* WR2 = ±10% in Air (inch squared lbs.)

M.W.R. = 0.37

B.T.F. = 0.048

DQX SPECIFICATIONS (0.735 E.A.R.)

DIAMETER		HUB DIMENSIONS (INCHES)			STANDARD TAPER BORE (INCHES)			MAXIMUM BLADE WIDTH (INCHES)	EXPANDED AREA PER BLADE (SQ.IN)	APPROX. NET WEIGHT (LBS.)	*WR ² (LBS.-IN ²)
INCHES	MM	AFT END	FORWARD END	LENGTH	MINIMUM BORE	MAXIMUM BORE	PILOT BORE				
17	432	2-1/4	2-1/2	3-1/4	1-1/4	1-1/2	1-1/4	7-3/16	41.4	16	279
18	457	2-3/8	2-5/8	3-1/4	1-1/4	1-3/4	1-1/4	7-5/8	46.4	18	370
19	483	2-3/8	2-5/8	3-3/4	1-1/4	1-3/4	1-1/4	8	51.9	21	482
20	508	2-3/8	2-5/8	3-3/4	1-1/4	1-3/4	1-1/4	8-7/16	57.7	24	621
21	533	2-3/4	3	4-1/8	1-3/8	2	1-3/8	8-7/8	63.2	29	794
22	559	2-3/4	3	4-1/8	1-3/8	2	1-3/8	9-5/16	69.6	33	997

* WR2 = ±10% in Air (inch squared lbs.)

M.W.R. = 0.33

B.T.F. = 0.046

DQX SPECIFICATIONS (0.81 E.A.R.)

DIAMETER		HUB DIMENSIONS (INCHES)			STANDARD TAPER BORE (INCHES)			MAXIMUM BLADE WIDTH (INCHES)	EXPANDED AREA PER BLADE (SQ.IN)	APPROX. NET WEIGHT (LBS.)	*WR ² (LBS.-IN ²)
INCHES	MM	AFT END	FORWARD END	LENGTH	MINIMUM BORE	MAXIMUM BORE	PILOT BORE				
23	406	3	3-1/4	FULL TAPER	1-1/2	2	1-1/2	10-5/8	83.7	45	1,392
24	432	3	3-1/4	FULL TAPER	1-1/2	2	1-1/2	11-1/16	91.4	50	1,714
25	457	3-3/8	3-3/4	FULL TAPER	1-3/4	2-1/4	1-3/4	11-9/16	98.6	60	2,111
26	483	3-3/8	3-3/4	FULL TAPER	1-3/4	2-1/4	1-3/4	12	106.9	65	2,557
27	508	3-3/4	4-1/8	FULL TAPER	2	2-1/2	2	12-1/2	114.8	77	3,099
28	533	3-3/4	4-1/8	FULL TAPER	2	2-1/2	2	12-15/16	123.8	83	3,700
30	559	4-1/4	4-5/8	FULL TAPER	2	3	2	13-7/8	141.5	110	5,240
32	584	4-1/4	4-5/8	FULL TAPER	2	3	2	14-3/4	161.8	126	7,176

* WR2 = ±10% in Air (inch squared lbs.)

M.W.R. = 0.37

B.T.F. = 0.046



Photo Courtesy of Sea Ray Corporation



Photo Courtesy of Tiara Yachts



Photo Courtesy of Silverton Marine Corp.

PLEASURE BOAT PROPELLERS

Available Alloys



Designed for the pleasure craft owner who looks for the ultimate performance and speed. The Dyna-Jet and Dyna-Quad are the most popular propeller series in the world for pleasure boat applications.

MICHIGAN PROPELLERS

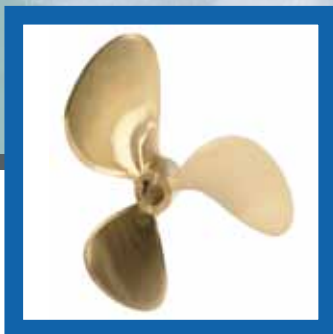

DYNA-JET

Specifications

0.56 E.A.R.

Diameter Range: 9" - 46"

Pitch Range: 0.7 - 1.1
(Pitch/Diameter Ratio)

The 3-blade Dyna-Jet provides outstanding speed and performance for moderately-sized boats. It has been the most popular propeller in the world for the past 50 years, and is still a standard for many 3-blade uses. Each Dyna-Jet is carefully hand-crafted and inspected to meet today's performance demands.

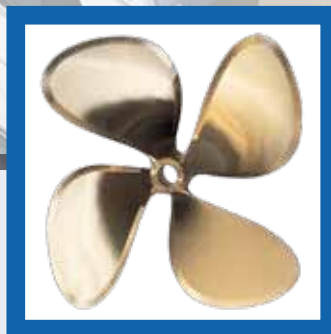

DYNA-QUAD

Specifications

0.69 E.A.R.

Diameter Range: 17" - 46"

Pitch Range: 0.7 - 1.1
(Pitch/Diameter Ratio)

As popular as the Dyna-Jet model, the Dyna-Quad may offer a more comfortable ride, reducing the vibrations of a 3-blade, while providing more thrust via greater blade area. This makes the Dyna-Quad an excellent choice for the performance-minded commercial boat operator.

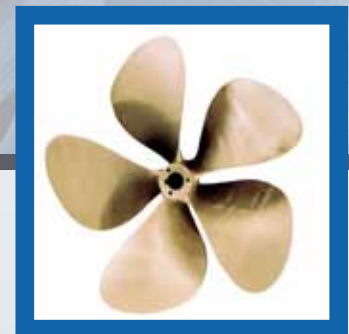

M-500

Specifications

0.86 E.A.R.

Diameter Range: 22" - 46"

Pitch Range: 0.75 - 1.3
(Pitch/Diameter Ratio)

For new construction, re-powers, and upgrading propellers, the 5-blade M-500 is the right choice. Its excellent design and increased blade area provide superior performance without increasing diameter, and may be the solution to problems such as: clearance or tip speed considerations; heavy vee-struts, dead wood or other hull appendages agitating the flow of water; vibration caused by resonance.

DYNA-JET & DYNA-QUAD SPECIFICATIONS								DYNA-JET (0.56 E.A.R.)				DYNA-QUAD (0.69 E.A.R.)			
DIAMETER		HUB DIMENSIONS (INCHES)			STANDARD TAPER BORE (INCHES)			MAXIMUM BLADE WIDTH (INCHES)	EXPANDED AREA PER BLADE (SQ.IN)	APPROX. NET WEIGHT (LBS.)	*WR ² (LBS.-IN ²)	MAXIMUM BLADE WIDTH (INCHES)	EXPANDED AREA PER BLADE (SQ.IN)	APPROX. NET WEIGHT (LBS.)	*WR ² (LBS.-IN ²)
INCHES	MM	AFT END	FORWARD END	LENGTH	MINIMUM BORE	MAXIMUM BORE	PILOT BORE								
9	229	1-3/8	1-1/2	2-1/8	3/4	7/8	3/4	3-7/8	11.7	2.5	10	-	-	-	-
10	254	1-1/2	1-5/8	2-1/4	3/4	1	3/4	4-5/16	14.5	3	17	-	-	-	-
11	279	1-1/2	1-5/8	2-1/4	3/4	1	3/4	4-3/4	17.7	4	26	-	-	-	-
12	305	1-5/8	1-3/4	2-3/8	7/8	1-1/8	7/8	5-3/16	21.1	5	40	-	-	-	-
13	330	1-5/8	1-13/16	2-3/4	1	1-1/8	1	5-5/8	24.8	6	60	-	-	-	-
14	356	1-7/8	2	2-3/4	1	1-1/4	1	6	28.7	8	86	-	-	-	-
15	381	1-7/8	2	2-3/4	1	1-1/4	1	6-7/16	33.1	9	120	-	-	-	-
16	406	2-1/8	2-3/8	3-1/4	1-1/8	1-3/8	1-1/8	6-7/8	37.5	11	167	-	-	-	-
17	432	2-1/8	2-3/8	3-1/4	1-1/4	1-3/8	1-1/4	7-5/16	42.8	13	224	6-3/4	38.7	14	257
17**	432	2-3/8	2-5/8	3-3/4	1-1/4	1-1/2	1-1/4	7-5/16	42.8	13	224	-	-	-	-
18	457	2-3/8	2-5/8	3-3/4	1-1/4	1-1/2	1-1/4	7-3/4	47.4	16	298	7-1/8	43.2	17	341
19	483	2-3/8	2-5/8	3-3/4	1-1/4	1-1/2	1-1/4	8-3/16	53.1	18	388	7-1/2	48.3	20	445
20	508	2-3/8	2-5/8	3-3/4	1-1/4	1-1/2	1-1/4	8-5/8	59.0	20	500	7-15/16	53.7	23	573
21	533	2-3/4	3	4-1/8	1-3/8	1-3/4	1-3/8	9-1/16	64.6	25	640	8-5/16	58.8	28	733
22	559	2-3/4	3	4-1/8	1-3/8	1-3/4	1-3/8	9-1/2	71.2	28	803	8-11/16	64.8	31	920
23	584	3	3-1/4	4-1/2	1-1/2	2	1-1/2	9-7/8	77.6	33	1,004	9-1/16	70.6	36	1,150
24	610	3	3-1/4	4-1/2	1-1/2	2	1-1/2	10-3/8	84.7	36	1,237	9-1/2	77.1	40	1,216
26	660	3-3/8	3-3/4	4-7/8	1-3/4	2-1/4	1-3/4	11-1/4	99.1	46	1,844	10-1/4	90.2	52	2,110
28	711	3-3/4	4-1/8	5-3/4	2	2-1/2	2	12-1/16	114.7	60	2,671	11-1/16	104.4	66	3,056
30	762	4-1/4	4-5/8	6	2	3	2	12-15/16	131.1	76	3,775	11-7/8	119.3	84	4,316
32	813	4-1/4	4-5/8	6	2	3	2	13-3/4	150.0	88	5,172	12-5/8	136.5	97	5,917
34	864	4-1/4	4-5/8	6-1/2	2-1/4	3	2-1/4	14-5/8	170.0	101	6,973	13-7/16	154.7	112	7,978
36	914	4-5/8	5-1/8	8	2-3/4	3-1/2	2-3/4	15-1/2	190.1	124	9,289	14-1/4	173.0	138	10,622
38	965	4-5/8	5-1/8	8	2-3/4	3-1/2	2-3/4	16-3/8	212.7	140	12,108	15	193.5	156	13,851
40	1,016	5	5-1/2	9	3	3-3/4	3	17-1/4	235.3	168	15,646	15-13/16	214.1	186	17,892
42	1,067	5-3/8	6	10-7/16	3	4	3	18-1/8	258.8	205	20,016	16-5/8	235.5	226	22,878
44	1,118	5-7/16	6-3/16	11	3	4	3	19	284.5	233	25,187	17-3/8	258.9	258	28,790
46	1,168	5-5/8	6-1/4	11-7/8	3	4	3	19-7/8	311.5	266	31,385	18-3/16	283.5	293	35,376

* WR2 = ±10% in Air (inch squared lbs.)

For Dyna-Jet M.W.R. = 0.33 B.T.F. = 0.050
 For Dyna-Quad M.W.R. = 0.33 B.T.F. = 0.047

** For Dyna-Jet Series propellers only - Sizes (Dia. x Pitch) 17x16, 17x17 & 17x18 maximum bore is 1-1/2". All other 17" diameter sizes - maximum bore is 1-3/8".

M-500 SPECIFICATIONS (0.86 E.A.R.)												
DIAMETER		HUB DIMENSIONS (INCHES)			STANDARD TAPER BORE (INCHES)			MAXIMUM BLADE WIDTH (INCHES)	EXPANDED AREA PER BLADE (SQ.IN)	APPROX. NET WEIGHT (LBS.)	*WR ² (LBS.-IN ²)	
INCHES	MM	AFT END	FORWARD END	LENGTH	MINIMUM BORE	MAXIMUM BORE	PILOT BORE					
22	356	2-3/4	3	4-1/8	1-3/8	1-3/4	1-3/8	8-11/16	64.9	37	1,150	
23	381	3	3-1/4	4-1/2	1-1/2	2	1-1/2	9-1/16	70.6	43	1,430	
24	406	3	3-1/4	4-1/2	1-1/2	2	1-1/2	9-1/2	77.1	48	1,770	
26	432	3-3/8	3-3/4	4-7/8	1-3/4	2-1/4	1-3/4	10-1/2	90.2	62	2,630	
28	457	3-3/4	4-1/8	5-3/4	2	2-1/2	2	11-1/16	104.4	79	3,810	
30	483	4-1/4	4-5/8	6	2	3	2	11-7/8	119.3	99	5,380	
32	508	4-1/4	4-5/8	6	2	3	2	12-5/8	136.5	115	7,380	
34	533	4-1/4	4-5/8	6-1/2	2-1/4	3	2-1/4	13-7/16	154.7	134	9,960	
36	559	4-5/8	5-1/8	8	2-3/4	3-1/2	2-3/4	14-1/4	173.0	164	13,250	
38	584	4-5/8	5-1/8	8	2-3/4	3-1/2	2-3/4	15	193.5	186	17,280	
40	610	5	5-1/2	9	3	3-3/4	3	15-7/8	214.1	221	22,320	
42	660	5-3/8	6	10-7/16	3	4	3	16-9/16	235.5	267	28,520	
44	711	5-7/16	6-3/16	11	3	4	3	17-3/8	258.9	305	35,900	
46	762	5-5/8	6-1/4	11-7/8	3	4	3	18-3/16	283.5	347	44,740	

* WR2 = ±10% in Air (inch squared lbs.)

M.W.R. = 0.37

B.T.F. = 0.046

SAILBOAT PROPELLERS

Available Alloys



Michigan fixed pitch propellers are designed to produce performance - with or without wind.

SAILBOAT PROPELLERS



SAILER 2-BLADE

Specifications

0.31 E.A.R.

Diameter Range: 10" - 20"

The 2-Blade Sailer fixed pitch propeller is the popular choice for sailboaters seeking to maximize speed. It offers minimum drag while under sail and the power to get you where you're going when the wind stops blowing.

SAILER 3-BLADE

Specifications

0.46 E.A.R.

Diameter Range: 10" - 20"

The 3-Blade Sailer is the propeller of choice for the cruising sailboats. It offers superior dock handling maneuverability and the power to maintain speed in wind and waves when the weather gets nasty with a minimum increase in drag under sail.



SAILER 2 & 3 BLADE SPECIFICATIONS

DIAMETER		HUB DIMENSIONS (INCHES)			STANDARD TAPER BORE (INCHES)		
INCHES	MM	AFT END	FORWARD END	LENGTH	MINIMUM BORE	MAXIMUM BORE	PILOT BORE
10	254	1-7/16	1-5/8	2-1/4	3/4	7/8	3/4
11	280	1-7/16	1-5/8	2-1/4	3/4	7/8	3/4
12	305	1-9/16	1-3/4	2-3/8	7/8	1-1/8	7/8
13	330	1-9/16	1-3/4	2-3/4	1	1-1/8	1
14	356	1-3/4	2	2-3/4	1	1-1/8	1
15	381	1-3/4	2	2-3/4	1	1-1/8	1
16	406	1-15/16	2-3/16	3-1/4	1-1/8	1-1/4	1-1/8
17	432	2	2-5/16	3-1/4	1-1/8	1-3/8	1-1/8
18	457	2	2-5/16	3-1/4	1-1/8	1-3/8	1-1/8
19	483	2-1/8	2-7/16	3-3/4	1-1/4	1-3/8	1-1/4
20	508	2-1/8	2-7/16	3-3/4	1-1/4	1-3/8	1-1/4

MUD BOAT PROPELLERS

Available Alloys



WEEDLESS A-C SPECIFICATIONS

DIAMETER		AVAILABLE PITCH	HUB DIMENSIONS (INCHES)			MAXIMUM STRAIGHT BORE (INCHES)	MAXIMUM BLADE WIDTH (INCHES)	EXPANDED AREA PER BLADE (SQ. IN)	APPROX. NET WEIGHT (LBS.)	B.T.F.
INCHES	MM		AFT END	FORWARD END	LENGTH					
6	152		1	1-11/32	1-3/8	1/2	2-5/8	6.2	1	.042
7	178	4L	1-1/16	1-1/2	1-1/2	5/8	3-1/8	8.5	1.5	.042
8	203	6L	1-1/8	1-1/2	1-1/2	5/8	3-9/16	10.8	2	.042
9	229	6L, 7L, 8L	1-1/4	1-11/16	1-7/8	3/4	4-1/8	13.7	3	.042
10	254	6L, 10L	1-7/16	1-3/4	2-1/4	3/4	4-11/16	14.7	3.5	.042

WEEDLESS W-C SPECIFICATIONS

DIAMETER		AVAILABLE PITCH	HUB DIMENSIONS (INCHES)			MAXIMUM STRAIGHT BORE (INCHES)	MAXIMUM BLADE WIDTH (INCHES)	EXPANDED AREA PER BLADE (SQ. IN)	APPROX. NET WEIGHT (LBS.)	B.T.F.
INCHES	MM		AFT END	FORWARD END	LENGTH					
6	152	4L, 5L	1	1-11/32	1-3/8	1/2" Straight No Keyway	2-5/8	6.2	1	.042
7	178	4L, 5L, 8L, 10L	1-1/16	1-1/2	1-1/2	1/2" Straight No Keyway	3-1/8	8.5	1.5	.042
8	203	4L, 5L	1-1/8	1-1/2	1-1/2	5/8" Straight No Keyway	3-9/16	10.8	2	.042
9	229	5L, 6L	1-1/4	1-11/16	1-7/8	5/8" or 3/4" Straight & Slot	4-1/8	13.7	3	.042
10	254	5L, 9L	1-7/16	1-3/4	2-1/4	3/4" Taper & Keyway	4-11/16	14.7	3.5	.042

WEEDLESS H-D SPECIFICATIONS

DIAMETER		AVAILABLE PITCH	HUB DIMENSIONS (INCHES)			MAXIMUM STANDARD TAPER BORE (INCHES)	MAXIMUM STRAIGHT BORE (INCHES)	MAXIMUM BLADE WIDTH (INCHES)	EXPANDED AREA PER BLADE (SQ. IN)	APPROX. NET WEIGHT (LBS.)	B.T.F.
INCHES	MM		AFT END	FORWARD END	LENGTH						
10	254	6R, 8, 10, 12	1-7/16	1-5/8	2-1/4	1	1	6-11/16	21	5	.058
11	279	8, 10, 12	1-7/16	1-5/8	2-1/4	1	1	7-7/16	25	6	.058
12	305	10, 12, 14	1-9/16	1-3/4	2-5/8	1-1/8	1-1/4	8	30	7.5	.058
13	330	8, 10, 12, 14	1-9/16	1-3/4	2-5/8	1-1/8	1-1/4	8-13/16	36	9	.058
14	356	8, 10, 12L, 14, 16	1-3/4	2	3	1-1/8	1-1/4	9-7/16	41	12	.058
15	381	8, 10, 12, 13L, 14, 16	1-3/4	2	3	1-1/8	1-1/4	10	47	14	.058
16	406	8-16 Even	1-15/16	2-3/16	3-3/8	1-1/4	1-3/8	10-11/16	55	16	.058



WEEDLESS A-C Specifications

Diameter Range: 6" - 10"
Straight Bore

The Weedless A-C Series is primarily for smaller air-cooled inboard engines.



WEEDLESS W-C Specifications

Diameter Range: 6" - 10"
Tapered Bore

The Weedless W-C Series offers heavier blades and a larger hub for water cooled engines.



WEEDLESS H-D Specifications

Diameter Range: 10" - 16"
Standard Taper Bores

The Weedless H-D (Heavy Duty) is designed for maximum strength and durability in weed infested waters. It is designed to take on the heaviest of weeds.

COMMERCIAL BOAT PROPELLERS

Commercial propellers that are modeled after the popular Dyna-Quad pleasure series.

COMMERCIAL PROPELLERS

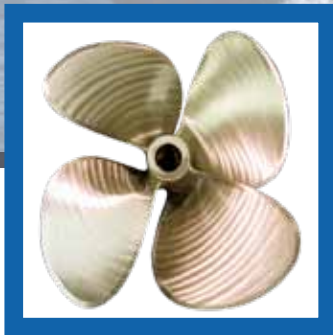

DQ SPECIAL

Specifications

0.76 - 0.91 E.A.R.

Diameter Range: 32" - 56"

The DQ Special is an authoritative extension of the traditional Dyna-Quad design, boasting more muscle through more blade area. It is available in larger diameters, with area ratios suitable for today's high-powered vessels. It makes for an ideal option for large super yachts, as well as commercial boats operating at higher speeds.

Available Alloys

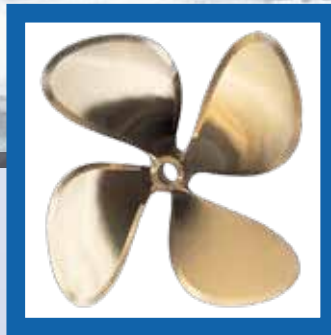

DURA-QUAD

Specifications

0.76 E.A.R.

Diameter Range: 24" - 36"

The Dura-Quad is ideal for applications where more durability and/or blade area is required. Dura-Quad propellers have the skewed and highly efficient blade design of the traditional Dyna-Quad series. The added blade thickness optimizes speed on high-powered commercial applications, without sacrificing durability.

Available Alloys



PAC-MASTER

Specifications

0.69 E.A.R.

Even Diameters: 20" - 30"

Pac-Master features a durable design to ensure long running life. The increased blade-root thickness gives extra durability for any and all applications. CF3 Stainless Steel is used to ensure rugged, dependable operation. The Pac-Master is available in select even-diameters. Odd-diameters and pitch combinations are available upon request.

Available Alloys



DQ SPECIAL SPECIFICATIONS (0.86 E.A.R.)

DIAMETER		HUB DIMENSIONS (INCHES)			STANDARD TAPER BORE (INCHES)			MAXIMUM BLADE WIDTH (INCHES)	EXPANDED AREA PER BLADE (SQ.IN)	APPROX. NET WEIGHT (LBS.)	*WR ² (LBS.-IN ²)
INCHES	MM	AFT END	FORWARD END	LENGTH	MINIMUM BORE	MAXIMUM BORE	PILOT BORE				
32	813	4-1/4	4-7/8	FULL TAPER	2	3	2	15-11/16	173.1	128	8,250
34	864	4-1/2	5-1/8	FULL TAPER	2-1/4	3	2-1/4	16-11/16	196.3	152	11,150
36	914	4-7/8	5-9/16	FULL TAPER	2-3/4	3-1/2	2-3/4	17-11/16	219.5	184	14,850
38	965	4-7/8	5-9/16	FULL TAPER	2-3/4	3-1/2	2-3/4	18-5/8	245.5	207	19,270
40	1,016	4-7/8	5-11/16	FULL TAPER	3	3-3/4	3	19-5/8	271.6	233	24,710
42	1,067	5-3/8	6	FULL TAPER	3	4	3	20-5/8	298.8	275	31,620
44	1,118	5-3/8	6	FULL TAPER	3	4-1/4	3	21-9/16	328.5	300	39,630
46	1,168	6	6-3/4	FULL TAPER	3	4-1/2	3	22-9/16	359.6	352	46,690
48	1,219	6	6-3/4	FULL TAPER	3	4-1/2	3	23-3/8	387.5	390	61,190
50	1,270	6-3/4	7-1/2	FULL TAPER	3	5	3	24-7/16	420.5	460	75,570
52	1,321	6-3/4	7-1/2	FULL TAPER	3	5	3	25-7/16	456.2	505	91,460
54	1,372	6-3/4	7-1/2	FULL TAPER	3	5	3	26-7/16	493.3	552	109,740
56	1,422	6-3/4	7-1/2	FULL TAPER	3	5	3	27-3/8	531.9	604	131,130

* WR2 = ±10% in Air (inch squared lbs.)

Notes:

1. Mass moment of inertia properties calculated using minimum standard bore.
2. Mass moment of inertia properties calculated using bronze.
3. Some DQ Specials have blade area other than 0.86.

DURA-QUAD SPECIFICATIONS (0.76 E.A.R.)

DIAMETER		HUB DIMENSIONS (INCHES)			STANDARD TAPER BORE (INCHES)				MAXIMUM BLADE WIDTH (INCHES)	EXPANDED AREA PER BLADE (SQ.IN)	APPROX. NET WEIGHT (LBS.)	*WR ² (LBS.-IN ²)
INCHES	MM	AFT END	FORWARD END	LENGTH	MINIMUM BORE	MAXIMUM BORE	PILOT BORE	PILOT S. E. BORE				
24	610	3	3-3/8	6	1-1/2	2	1-1/2	1.172	10-7/16	85.5	52	1,780
26	660	3-3/8	3-7/8	6-3/4	1-3/4	2-1/4	1-3/4	1.375	11-5/16	99.9	67	2,650
28	711	3-3/4	4-1/4	7-1/2	2	2-1/2	2	1.578	12-3/16	115.7	85	3,830
30	762	4-1/4	4-7/8	9	2	3	2	1.531	13-1/16	132.1	113	5,420
32	813	4-1/4	4-7/8	9	2	3	2	1.531	13-15/16	151.1	129	7,420
34	864	4-1/4	4-7/8	9	2	3	2	1.531	14-13/16	171.4	148	9,980
36	914	4-5/8	5-1/4	10-1/2	2-3/4	3-1/2	2-3/4	2.164	15-5/8	191.8	176	13,260

* WR2 = ±10% in Air (inch squared lbs.)

PAC-MASTER SPECIFICATIONS (0.69 E.A.R.)

DIAMETER		ROTATION	HUB DIMENSIONS (INCHES)			STANDARD TAPER BORE (INCHES)			MAXIMUM BLADE WIDTH (INCHES)	EXPANDED AREA PER BLADE (SQ.IN)	APPROX. NET WEIGHT (LBS.)	*WR ² (LBS.-IN ²)
INCHES			AFT END	FORWARD END	LENGTH	MINIMUM BORE	MAXIMUM BORE	PILOT BORE				
20 x 18		R	2-3/4	3	4-1/2	1-1/2	1-3/4	1-1/2	8-1/16	54.2	26	627
20 x 20		R	2-3/4	3	4-1/2	1-1/2	1-3/4	1-1/2	8-1/16	54.2	26	627
22 x 18		R	3	3-1/4	4-7/8	1-3/4	2	1-3/4	8-7/8	65.5	34	1,003
22 x 20		R	3	3-1/4	4-7/8	1-3/4	2	1-3/4	8-7/8	65.5	34	1,003
22 x 22		R	3	3-1/4	4-7/8	1-3/4	2	1-3/4	8-7/8	65.5	34	1,003
24 x 20		R & L	3-3/8	3-3/4	5-3/4	2	2-1/4	2	9-11/16	77.8	46	1,545
24 x 22		R & L	3-3/8	3-3/4	5-3/4	2	2-1/4	2	9-11/16	77.8	46	1,545
24 x 24		R & L	3-3/8	3-3/4	5-3/4	2	2-1/4	2	9-11/16	77.8	46	1,545
26 x 20		R & L	3-7/8	4-1/4	6	2	2-1/2	2	10-1/2	90.9	61	2,302
26 x 22		R & L	3-7/8	4-1/4	6	2	2-1/2	2	10-1/2	90.9	61	2,302
26 x 24		R & L	3-7/8	4-1/4	6	2	2-1/2	2	10-1/2	90.9	61	2,302
26 x 26		R & L	3-7/8	4-1/4	6	2	2-1/2	2	10-1/2	90.9	61	2,302
26 x 30		R & L	3-7/8	4-1/4	6	2	2-1/2	2	10-1/2	90.9	61	2,302
28 x 26		R & L	3-7/8	4-1/4	6	2	2-1/2	2	11-1/4	106.2	72	3,303
28 x 28		R & L	3-7/8	4-1/4	6	2	2-1/2	2	11-1/4	106.2	72	3,303
30 x 20		R	3-7/8	4-1/4	6-1/2	2	2-1/2	2	12-1/16	122.5	85	4,633
30 x 28		R & L	3-7/8	4-1/4	6-1/2	2	2-1/2	2	12-1/16	122.5	85	4,633
30 x 30		R	3-7/8	4-1/4	6-1/2	2	2-1/2	2	12-1/16	122.5	85	4,633

* WR2 = ±10% in Air (inch squared lbs.)

M.W.R. = 0.326

B.T.F. = 0.060

Odd diameter & pitch within 2" of listed are quoted on request.

MACHINE PITCH

Specifications

0.51 E.A.R. - Diameter Range: 9" - 60"

0.47 E.A.R. - Diameter Range: 62" - 96"

The most well-known, finest crafted 3-blade propeller for all purpose use. This style and design is primarily used on vessels with speeds less than 15 knots. The design of MP-style propellers include: semi-elliptical shape; constant pitch; and ogival blade sections.

The Heavy Duty (HD) is identical in design to the Machine Pitch, but incorporates thicker blade edges, engineered specifically for severe conditions. These edges resist abrasion and blade fracture.

Available Alloys



WORK HORSE

Specifications

0.71 E.A.R. - Diameter Range: 18" - 60"

0.622 E.A.R. - Diameter Range: 62" - 96"

The Work Horse is the best known commercial propeller in the world. Tug and push boat operators choose the Work Horse for its semi-elliptical shape, excellent reverse-thrust performance and ability to push hard-working boats.

Available Alloys

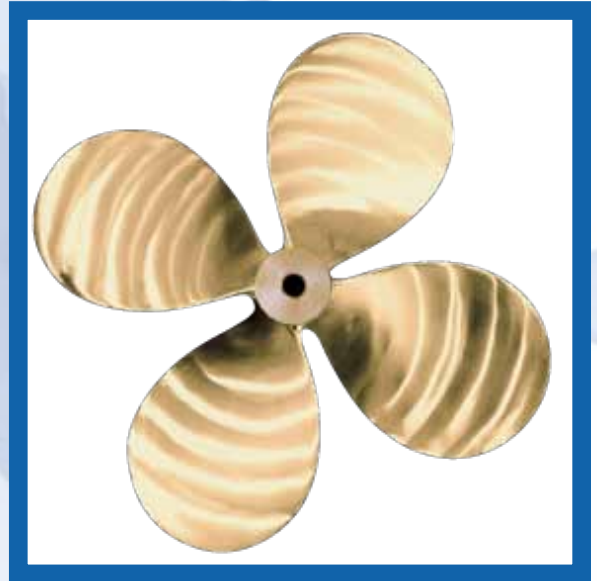

WORK HORSE 5

Specifications

0.8875 E.A.R.

Diameter Range: 30" x 60"

The Work Horse 5 propeller is a recent evolution of the traditional Work Horse propeller. The increased blade number provides additional blade area for commercial applications with higher horsepower and thrust requirements. Additionally, the Work Horse 5 will help to reduce vibration levels on vessels where non-uniform water flow or propeller tip clearance limitations exist.

Available Alloys

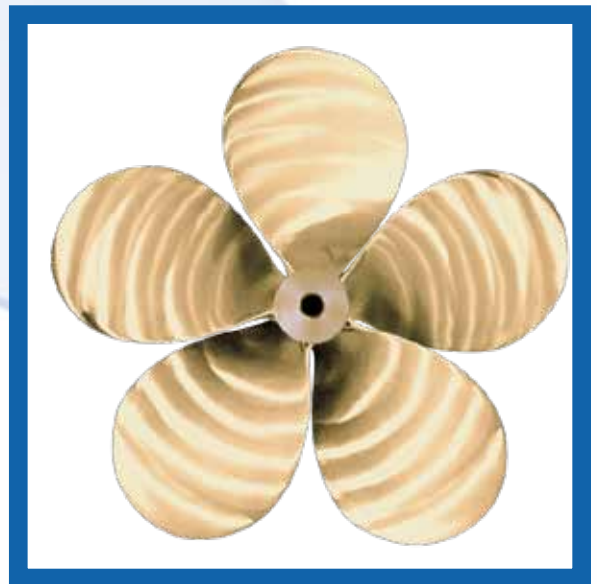

MACHINE PITCH & WORK HORSE SPECIFICATIONS										MACHINE PITCH		WORK HORSE		WORK HORSE 5	
DIAMETER		HUB DIMENSIONS (INCHES)			STANDARD TAPER BORE (INCHES)			MAXIMUM BLADE WIDTH (INCHES)	EXPANDED AREA PER BLADE (SQ.IN)	APPROX. NET WEIGHT (LBS.)	*WR ² (LBS.-IN ²)	APPROX. NET WEIGHT (LBS.)	*WR ² (LBS.-IN ²)	APPROX. NET WEIGHT (LBS.)	*WR ² (LBS.-IN ²)
INCHES	MM	AFT END	FORWARD END	LENGTH	MINIMUM BORE	MAXIMUM BORE	PILOT BORE								
9	229	1-5/16	1-7/16	2-1/8	3/4	3/4	3/4	3-7/8	11.8	2.5	13	-	-	-	-
10	254	1-7/16	1-5/8	2-1/8	3/4	7/8	3/4	4-5/16	14.5	3.5	21	-	-	-	-
11	279	1-7/16	1-5/8	2-1/8	3/4	7/8	3/4	4-5/8	17.6	4	34	-	-	-	-
12	305	1-9/16	1-3/4	2-5/8	7/8	1-1/8	7/8	5-1/16	20.9	5	50	-	-	-	-
13	330	1-9/16	1-3/4	2-3/4	1	1-1/8	1	4-15/16	22.7	6	65	-	-	-	-
14	356	1-3/4	2	3	1	1-1/8	1	5-5/16	26.4	8	90	-	-	-	-
15	381	1-3/4	2	3	1	1-1/8	1	5-5/8	30.3	9	120	-	-	-	-
16	406	1-15/16	2-3/16	3-3/8	1-1/8	1-1/4	1-1/8	6-15/16	34.5	11	160	-	-	-	-
17	432	2	2-5/16	3-3/8	1-1/8	1-3/8	1-1/8	6-7/16	38.9	12	210	-	-	-	-
18	457	2	2-5/16	3-3/8	1-1/8	1-3/8	1-1/8	6-7/8	43.6	14	280	17	370	-	-
19	483	2-1/8	2-7/16	3-3/4	1-1/4	1-3/8	1-1/4	7-1/4	48.6	16	350	20	480	-	-
20	508	2-1/8	2-7/16	3-3/4	1-1/4	1-3/8	1-1/4	7-1/2	53.8	18	470	23	630	-	-
21	533	2-7/16	2-13/16	4-1/8	1-3/8	1-1/2	1-3/8	8	59.4	22	590	28	790	-	-
22	559	2-7/16	2-13/16	4-1/8	1-3/8	1-1/2	1-3/8	8-3/8	65.1	25	760	32	1,020	-	-
23	584	2-13/16	3-3/16	4-1/2	1-1/2	1-3/4	1-1/2	8-7/8	71.2	30	940	38	1,250	-	-
24	610	2-13/16	3-3/16	4-1/2	1-1/2	1-3/4	1-1/2	9-1/8	77.5	33	1,140	41	1,510	-	-
26	660	3-3/16	3-5/8	5-1/4	1-3/4	2	1-3/4	9-7/8	91	44	1,710	54	2,280	-	-
28	711	3-1/2	4	5-1/4	1-3/4	2-1/4	1-3/4	10-5/8	105.5	55	2,490	68	3,320	-	-
30	762	3-13/16	4-3/8	6	2	2-1/2	2	11-3/8	124.7	70	3,460	87	4,590	108	6,100
32	813	4-1/4	4-13/16	6	2	3	2	12-3/16	141.8	97	5,960	121	7,920	150	10,526
34	864	4-7/16	5-1/16	6-3/4	2-1/4	3-1/4	2-1/4	12-7/8	160.1	114	7,810	142	10,380	177	13,795
36	914	4-3/4	5-1/2	7	2-1/2	3-1/2	2-1/2	13-5/8	179.5	136	10,350	170	13,750	211	18,274
38	965	5-1/16	5-13/16	7-1/4	2-1/2	3-3/4	2-1/2	14-7/16	200	159	13,200	198	17,540	246	23,311
40	1,016	5-1/16	5-13/16	7-3/4	2-3/4	3-3/4	2-3/4	15-3/16	221.6	177	16,600	221	22,070	275	29,331
42	1,067	5-1/4	6	8	2-3/4	3-3/4	2-3/4	15-15/16	244.3	211	22,620	265	30,090	329	39,990
44	1,118	5-1/4	6	8	2-3/4	3-3/4	2-3/4	16-3/4	268.1	232	27,820	293	37,010	364	49,186
46	1,168	6	6-3/4	10	3	4	3	17-7/16	293.1	285	34,170	354	45,400	440	60,337
48	1,219	6	6-3/4	10	3	4	3	18-1/4	319.1	309	41,290	386	54,900	480	72,962
50	1,270	6-9/16	7-3/8	10-3/4	3	4-1/2	3	19	346.2	362	49,820	447	66,190	556	87,967
52	1,320	6-9/16	7-3/8	10-3/4	3	4-1/2	3	19-3/4	374.5	390	59,370	485	78,900	603	104,858
54	1,371	6-9/16	7-3/8	10-3/4	3	4-1/2	3	20-1/2	408.8	420	70,320	526	93,510	654	124,275
56	1,422	7-5/8	8-3/8	11-1/2	3-1/4	5	3-1/4	21-1/4	434.3	498	83,470	615	110,830	764	147,293
58	1,473	7-5/8	8-3/8	11-1/2	3-1/4	5	3-1/4	21-7/8	465.9	533	97,700	661	129,810	822	172,517
60	1,524	7-5/8	8-3/8	12	3-1/2	5	3-1/2	22-3/4	498.6	572	113,880	713	151,360	886	201,157
62	1,575	9	10	13-1/4	4	6	4	22-1/2	492.8	737	143,870	902	190,790	-	-
64	1,625	9	10	13-1/4	4	6	4	23-1/8	525.1	781	165,830	961	220,060	-	-
66	1,676	9	10	13-1/4	4	6	4	23-15/16	558.4	828	190,420	1,024	252,850	-	-
68	1,727	10-1/2	11-3/4	14-1/2	5	7	5	24-5/8	592.8	987	221,140	1,199	292,710	-	-
70	1,778	10-1/2	11-3/4	14-1/2	5	7	5	25-3/8	628.1	1,039	251,690	1,269	333,450	-	-
72	1,823	10-1/2	11-3/4	14-1/2	5	7	5	26-1/8	664.5	1,094	285,590	1,342	378,650	-	-
74	1,879	10-1/2	11-3/4	14-1/2	6	7	6	26-7/8	702	1,159	340,800	1,436	452,320	-	-
76	1,930	10-1/2	11-3/4	14-1/2	6	7	6	27-9/16	740.4	1,228	388,680	1,529	516,160	-	-
78	1,981	10-1/2	11-3/4	14-1/2	6	7	6	28-1/4	779.9	1,301	441,530	1,626	586,630	-	-
80	2,032	11-1/8	12-1/2	17	6	7-1/2	6	29	820.4	1,493	503,610	1,844	668,350	-	-
82	2,083	11-1/8	12-1/2	17	6	7-1/2	6	29-3/4	862	1,574	568,320	1,952	754,640	-	-
84	2,134	11-1/8	12-1/2	17	6	7-1/2	6	30-7/16	904.5	1,659	639,650	2,064	849,740	-	-
86	2,184	11-1/8	12-1/2	17	6	7-1/2	6	31-3/16	948.1	1,748	718,600	2,183	955,010	-	-
88	2,235	11-1/8	12-1/2	17	6	7-1/2	6	31-15/16	992.7	1,842	805,280	2,308	1,070,600	-	-
90	2,286	11-7/8	13-1/4	18-1/4	6	8	6	32-5/8	1,038.3	2,048	903,200	2,547	1,199,900	-	-
92	2,337	11-7/8	13-1/4	18-1/4	6	8	6	33-3/8	1,085.0	2,150	1,003,950	2,683	1,338,260	-	-
94	2,388	11-7/8	13-1/4	18-1/4	6	8	6	34-1/16	1,132.7	2,256	1,119,400	2,825	1,488,200	-	-
96	2,438	11-7/8	13-1/4	18-1/4	6	8	6	34-13/16	1,181.4	2,263	1,238,750	2,869	1,648,600	-	-



TRAWLER

Specifications

0.44 E.A.R. - Diameter Range: 36" - 72"

The Trawler series gives four blade performance without reduced diameter, and is primarily used on shrimp boats, trawlers and similar vessels that need thrust and smooth running performance.

Available Alloys

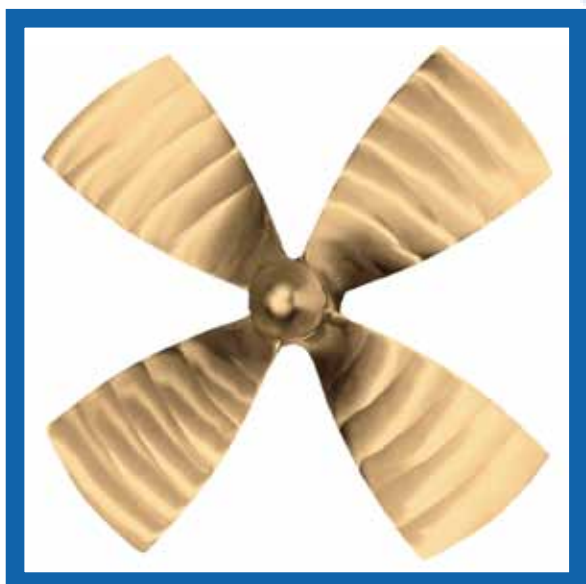

KAPLAN

Specifications

Standard 0.56 E.A.R.; 0.71 E.A.R.

Diameter Range: 35" - 95"

Custom & Skewed Configurations Available

The Kaplan propeller is designed for hard-working trawlers, druggers and tugs. The Kaplan is manufactured to operate in a nozzle and the design includes air foil sections at inner radii, and flat face ogival sections at outer radii.

Available Alloys

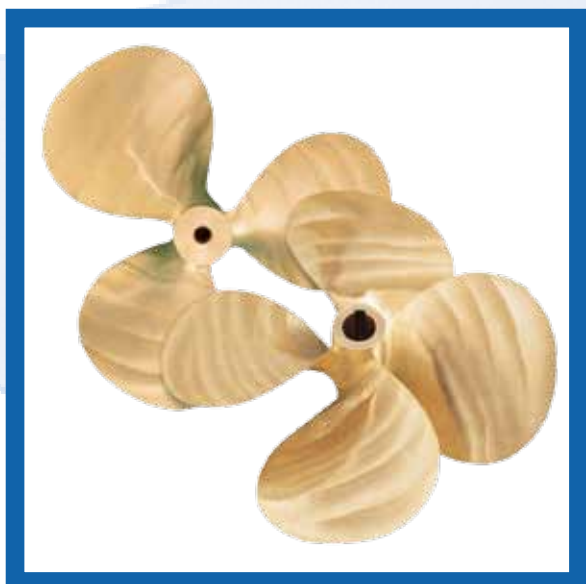

MAXIMA

Specifications

0.63 E.A.R. - 3 Blade

0.836 E.A.R. - 4 Blade

Diameter Range: 32" x 50"

The heavy-duty blade thickness distribution makes the Maxima the most durable commercial offering. The blade design is wider than the standard for applications that require maximum thrust, including: moderate-speed crew supply; high horsepower applications; and passenger boats requiring maximum thrust.

Available Alloys



TRAWLER SPECIFICATIONS (0.44 E.A.R.)

DIAMETER		HUB DIMENSIONS (INCHES)			STANDARD TAPER BORE (INCHES)			MAXIMUM BLADE WIDTH (INCHES)	EXPANDED AREA PER BLADE (SQ.IN)	APPROX. NET WEIGHT (LBS.)	*WR ² (LBS.-IN ²)
INCHES	MM	AFT END	FORWARD END	LENGTH	MINIMUM BORE	MAXIMUM BORE	PILOT BORE				
36	914	4-7/16	5-1/16	7	2-1/2	3-1/4	2-1/2	8-1/2	108.8	145	9,900
38	965	4-7/16	5-1/16	7	2-1/2	3-1/4	2-1/2	9	121.2	160	12,200
40	1,016	4-7/16	5-1/16	7	2-1/2	3-1/4	2-1/2	9-1/2	134.4	187	15,800
42	1,067	4-3/4	5-1/2	8	2-3/4	3-1/2	2-3/4	10	148.2	221	20,600
44	1,118	4-3/4	5-1/2	8	2-3/4	3-1/2	2-3/4	10-3/8	162.6	248	25,400
46	1,168	4-3/4	5-1/2	8	2-3/4	3-1/2	2-3/4	11	177.6	284	31,700
48	1,219	6	6-3/4	9	3	4	3	11-3/8	193.6	322	39,300
50	1,270	6	6-3/4	9	3	4	3	11-7/8	210.0	370	49,000
52	1,321	6	6-3/4	9	3	4	3	12-3/8	227.4	402	57,500
54	1,372	6-9/16	7-3/8	10-3/4	3-1/2	4-1/2	3-1/2	12-3/4	244.8	451	69,500
56	1,422	6-9/16	7-3/8	10-3/4	3-1/2	4-1/2	3-1/2	13-1/4	273.2	496	82,000
58	1,473	6-9/16	7-3/8	10-3/4	3-1/2	4-1/2	3-1/2	13-3/4	282.8	546	97,000
60	1,524	6-9/16	7-3/8	10-3/4	3-1/2	4-1/2	3-1/2	14-1/4	302.2	587	112,000
62	1,575	7-5/8	8-3/8	11-1/2	4	5	4	14-5/8	322.4	642	130,500
64	1,626	7-5/8	8-3/8	11-1/2	4	5	4	15-1/8	343.9	693	150,000
66	1,676	7-5/8	8-3/8	11-1/2	4	5	4	15-5/8	365.8	783	181,000
68	1,727	8	9	13-1/4	4	5-1/2	4	16-1/8	388.0	887	217,800
70	1,778	8	9	13-1/4	4	5-1/2	4	16-5/8	411.8	991	257,000
72	1,828	8	9	13-1/4	4	5-1/2	4	17	434.9	1,110	302,000

*WR2 = ±10% in Air (inch squared lbs.)

M.W.R. = 0.21

B.T.F. =
 32" - 34" Dia = 0.036
 36" - 60" Dia = 0.038
 62" - 70" Dia = 0.042

KAPLAN SPECIFICATIONS (0.56 E.A.R.)

DIAMETER		HUB DIMENSIONS (INCHES)			STANDARD TAPER BORE (INCHES)			MAXIMUM BLADE WIDTH (INCHES)	EXPANDED AREA PER BLADE (SQ.IN)	APPROX. NET WEIGHT (LBS.)	*WR ² (LBS.-IN ²)
INCHES	MM	AFT END	FORWARD END	LENGTH	MINIMUM BORE	MAXIMUM BORE	PILOT BORE				
35	889	4-3/4	5-1/2	7-1/2	2-1/2	3-1/2	2-1/2	10-9/16	135	117	6,650
39	991	5-1/16	5-13/16	8	2-3/4	3-3/4	2-3/4	11-3/4	167	154	11,300
43	1,090	5-1/4	6	8-1/4	2-3/4	3-3/4	2-3/4	12-7/8	203	196	18,240
45	1,140	6	6-3/4	10	3	4	3	13-9/16	222	246	23,220
47	1,190	6	6-3/4	10	3	4	3	14-3/16	243	269	28,650
51	1,300	6-9/16	7-3/8	10-3/4	3-1/2	4-1/2	3-1/2	15-3/8	286	341	43,110
53	1,350	6-9/16	7-3/8	10-3/4	3-1/2	4-1/2	3-1/2	15-7/8	309	371	51,920
55	1,400	7-5/8	8-3/8	11-1/2	4	5	4	16-5/8	333	445	63,600
59	1,500	7-5/8	8-3/8	12	4	5	4	17-3/4	383	521	89,230
63	1,600	9	10	13-1/4	4	6	4	19-3/16	436	701	126,330
67	1,700	10-1/2	11-3/4	14-1/2	5	7	5	20-5/8	494	907	175,980
71	1,800	10-1/2	11-3/4	14-1/2	5	7	5	21-11/16	554	1,011	231,530
75	1,905	10-1/2	11-3/4	14-1/2	5	7	5	22-3/4	618	1,128	300,500
79	2,006	11-1/8	12-1/2	17	6	7-1/2	6	24	687	1,350	391,360
83	2,108	11-1/8	12-1/2	17	6	7-1/2	6	25-1/16	758	1,493	495,870
87	2,209	11-1/8	12-1/2	17	6	7-1/2	6	26-1/8	832	1,650	621,740
91	2,311	11-7/8	13-1/4	18-1/4	6-1/2	8	6-1/2	27-7/16	911	1,915	780,850
95	2,413	11-7/8	13-1/4	18-1/4	6-1/2	8	6-1/2	28-1/2	993	2,104	961,860

*WR2 = ±10% in Air (inch squared lbs.)

Greater area ratios available and quoted upon request.

For use in commercial Kort Nozzle applications, resulting in 25-50% increased thrust compared to an open wheel, on low speed trawlers, draggers, and harbor tugs.

MAXIMA SPECIFICATIONS 3-BLADE (0.63 E.A.R.)

DIAMETER		HUB DIMENSIONS (INCHES)			STANDARD TAPER BORE (INCHES)			EXPANDED AREA PER BLADE (SQ.IN)	APPROX. NET WEIGHT (LBS.)	*WR ² (LBS.-IN ²)
INCHES	MM	AFT END	FORWARD END	LENGTH	MINIMUM BORE	MAXIMUM BORE	PILOT BORE			
32	813	4-1/4	4-7/8	9	2-1/4	3	2-1/4	166	107	5,672
34	864	4-5/8	5-3/8	10-1/2	2-1/2	3-1/2	2-1/2	188	130	7,716
36	914	4-5/8	5-3/8	10-1/2	2-1/2	3-1/2	2-1/2	210	149	10,200
38	965	4-7/8	5-5/8	11-1/4	2-3/4	3-3/4	2-3/4	234	174	13,354
40	1,016	5-1/8	5-7/8	12	3	4	3	260	202	17,248
42	1,067	5-1/8	5-7/8	12	3	4	3	286	229	21,917
44	1,118	5-1/8	5-7/8	12	3	4	3	314	258	27,560
46	1,168	5-1/8	5-7/8	12	3	4	3	343	290	34,324
48	1,219	6	6-7/8	11-1/4	3-1/2	4-1/2	3-1/2	374	343	42,804
50	1,270	6	6-7/8	11-1/4	3-1/2	4-1/2	3-1/2	406	381	52,323

*WR2 = ±10% in Air (inch squared lbs.)

MAXIMA SPECIFICATIONS 4-BLADE (0.836 E.A.R.)

DIAMETER		HUB DIMENSIONS (INCHES)			STANDARD TAPER BORE (INCHES)			EXPANDED AREA PER BLADE (SQ.IN)	APPROX. NET WEIGHT (LBS.)	*WR ² (LBS.-IN ²)
INCHES	MM	AFT END	FORWARD END	LENGTH	MINIMUM BORE	MAXIMUM BORE	PILOT BORE			
32	813	4-1/4	4-7/8	9	2-1/4	3	2-1/4	166	133	7,525
34	864	4-5/8	5-3/8	10-1/2	2-1/2	3-1/2	2-1/2	188	162	10,228
36	914	4-5/8	5-3/8	10-1/2	2-1/2	3-1/2	2-1/2	210	187	13,537
38	965	4-7/8	5-5/8	11-1/4	2-3/4	3-3/4	2-3/4	234	219	17,726
40	1,016	5-1/8	5-7/8	12	3	4	3	260	254	22,896
42	1,067	5-1/8	5-7/8	12	3	4	3	286	289	29,117
44	1,118	5-1/8	5-7/8	12	3	4	3	314	328	36,635
46	1,168	5-1/8	5-7/8	12	3	4	3	343	371	45,646
48	1,219	6	6-7/8	11-1/4	3-1/2	4-1/2	3-1/2	374	433	56,850
50	1,270	6	6-7/8	11-1/4	3-1/2	4-1/2	3-1/2	406	484	69,532

*WR2 = ±10% in Air (inch squared lbs.)



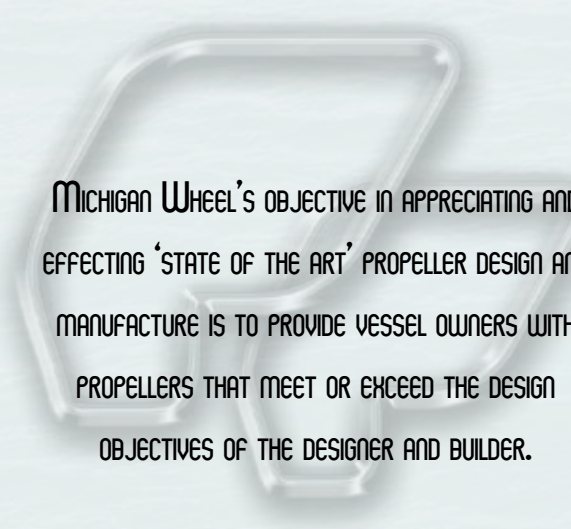

MICHIGAN WHEEL'S OBJECTIVE IN APPRECIATING AND EFFECTING 'STATE OF THE ART' PROPELLER DESIGN AND MANUFACTURE IS TO PROVIDE VESSEL OWNERS WITH PROPELLERS THAT MEET OR EXCEED THE DESIGN OBJECTIVES OF THE DESIGNER AND BUILDER.





**FEDERAL
PROPELLERS**



FEDERAL MANUFACTURING

ENGINEERED MANUFACTURING PROCESSES ARE EMPLOYED IN MANUFACTURING FEDERAL PROPELLERS TO SPECIFIC TOLERANCES.

PROCESS

Control

Each segment of manufacture has strict control and documentation. This control assures that the end product will result in close interpretation of design. The specific design and tolerance level created for the propellers on a particular application is determined by design expectations and analytical modeling of those expectations. The control level of manufacture, particularly in the NC machine finished propeller product, calls into question the use of gages to verify aspects that are programmed into the manufacture.

Tolerance

Federal Propellers are manufactured to close tolerance. Aspects of the manufacture meet the recognizable standard of ISO-484/2, Class 1 and Class S. The intent of establishing tolerance on Federal Propellers is to address the features most critical to end performance. 100% compliance with ISO standards, including development of specific thickness and edge gages, is exceptional.

Certifications



| ABS Certification



| Lloyd's Register





DESIGN CONSIDERATIONS

In working with builders, the Federal design team utilizes a number of tools and programs to optimize suggested propeller design.

Hull and Engine characteristics are plotted against data provided by the builder/boat designer and the engine companies:

Hull Characteristic

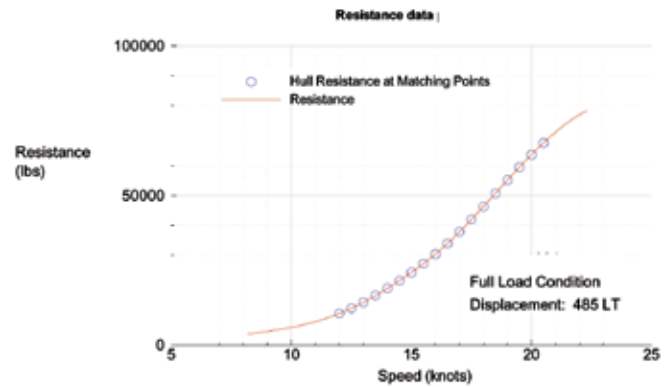

Engine Characteristic

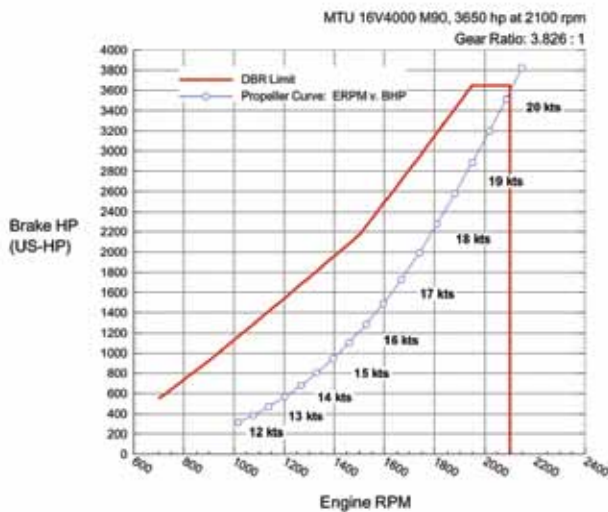

Consideration is given to the stresses on the propeller, in design:

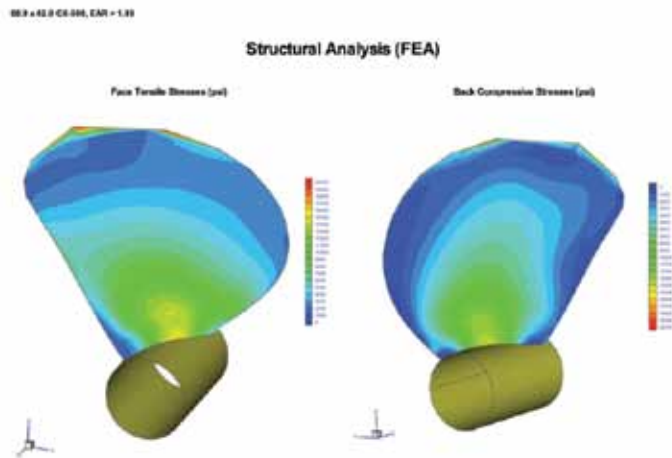



“MARLIN” SERIES

The result of major research and development undertaken with Maritime Research Associates LLC (MRA), MTU Detroit Diesel, and the Maritime Research Institute of the Netherlands (MARIN). Marlin propellers are for high power / high speed Sportfish and Sportcruiser models that are capable of speeds into the high 40 knot range.

GENERAL PROPELLERS



MARLIN 4

Specifications

0.825 - 0.90 E.A.R.



MARLIN 5

Specifications

0.90 - 1.05 E.A.R.

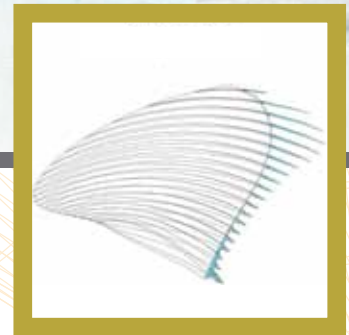

DESIGN CAVITATION PATTERN

(Looking Spanwise: Hub to Tip)

The Marlin Series is the result of a major research and development program undertaken with the Maritime Research Associates LLC (MRA), MTU Detroit Diesel, and the Maritime Research Institute of the Netherlands (MARIN). The applications are for high power / high speed Sportfish and Sportcruiser models that are capable of speeds into the high 40 knot range.

This series is primarily for new construction, involving Michigan Wheel at design, where consideration can be given to best appreciate of MARLIN configuration. The Marlin propellers in 4-blade will range from 0.825 to 0.90 E.A.R., and 0.90 to 1.05 E.A.R. in 5-blade.

The Marlin Series design features variable pitch, camber, skew, and a degree of rake. All Marlin propellers are fully CNC machine finished to high tolerance. The purpose of the series, beyond optimizing performance, is to manage cavitation.

“Y” SERIES

Available Alloys



Semi-custom series that offers many features and benefits of a full-custom propeller with the economics of series manufacture.

The “Y” is evolved from years of custom propeller design experiences. All “Y” propellers are fully CNC machine finished.

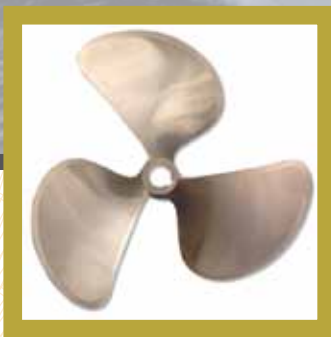

EPY

Specifications

0.66 E.A.R.



EQY

Specifications

0.835 E.A.R.



CY5

Specifications

0.935 E.A.R.

The chosen combination of blade area and skew in this series, along with variable pitch and camber, make for a close efficiency match throughout the entire engine power curves. Years of propeller design experience have allowed Michigan Wheel naval architects to optimize the “Y” design to maximize the performance of virtually all planing hulls. Increasingly, boat builders are choosing to install the “Y” series as standard equipment after appreciating the difference in sea trials compared to less sophisticated product.

Each EPY, EQY, and CY5 propeller is manufactured to exacting specifications, and inspected using the latest digital technology. Each propeller is given a serial number, permitting design and inspection data to be retrieved and reviewed for field service.

“CX” SERIES

Available Alloys



The best possible choice for propeller performance - Better cruise speed, better acceleration, improved fuel economy, and smoother, quieter operation.

The use of CNC machining and inspection technology ensures that every CX propeller is manufactured as designed. This process results in consistent and repeatable propeller manufacture, so replacement sets or spares will match the original.

GENERAL PROPELLERS

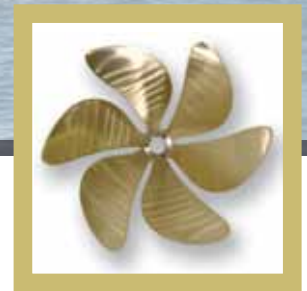
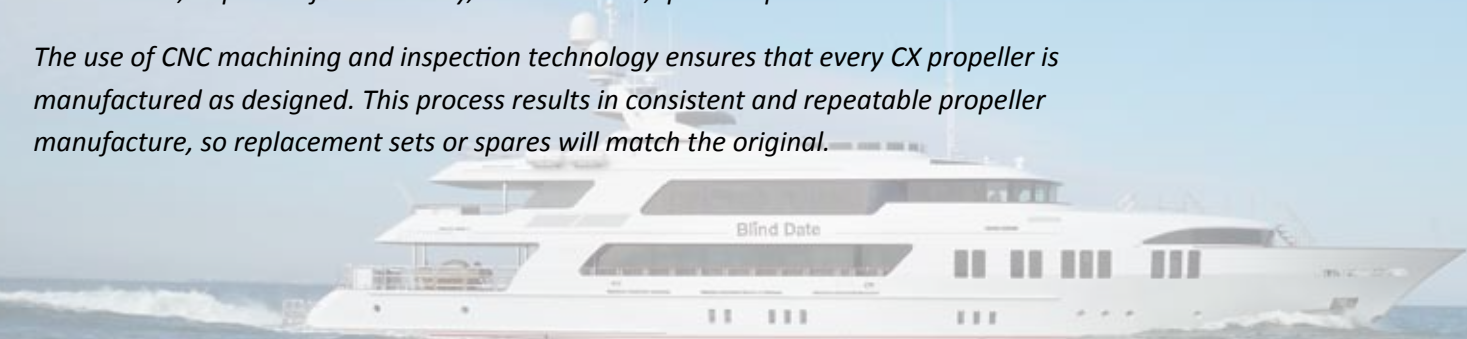

Michigan Wheel naval architects can design a custom propeller for your specific application. Using vessel data and performance targets provided by the customer, a propeller with the optimum combination of diameter, pitch, blade count, blade area, and camber is designed to maximize the performance of each yacht that is evaluated. All CX propellers are completely CNC machined to exacting specifications.

Michigan Wheel design and sales teams work closely with designers, yacht builders, propeller shops and owners to qualify optimal propellers for any given application. Michigan Wheel engineers use the latest in propeller design technology to design each propeller, including custom propeller geometry design code and sophisticated hydrodynamic analysis software. This allows the designer to maximize propeller efficiency while minimizing the performance robbing effects of cavitation. This is particularly important as engine horsepower and boat speeds continue to increase.



Every new CX Series propeller is given a 5-digit serial number, which gives customer service and repair agents a detailed history for a particular propeller. Field service requires sophisticated computerized propeller measurement equipment, i.e. Hale MRI, which can appreciate the original design and apply to any rework necessary. Michigan Wheel representatives work with repair facilities providing the necessary assistance to resolve propeller related issues.



“HX” SERIES

The Federal HX Series offers high tolerance hand finished propeller manufacture in a variety of design configurations. This series is primarily constant pitch, with expanded area ratios. High horsepower pleasure and commercial applications require specific propellers to achieve maximum thrust, speed, and smoothness. The proven pitch geometry yields exceptional performance without the additional cost associated with custom, CNC machined propellers.



“X” SERIES

EPX and EQX are an evolution of the tried and true Equi-Poise and Equi-Quad Series propellers. The designs have been modified to be better suited to highly loaded, limited tip clearance applications. New manufacturing technologies, such as machine finishing, are utilized in manufacture to facilitate accurate and repeatable product. Availability will be size specific, in a range of bores, without or with all degrees of cup.



EQUI-POISE & EQUI-QUAD

The Federal Equi-Poise three blade and Equi-Quad four blade propeller series are for applications that benefit from traditional propeller geometry held to a close tolerance. The proven performance of these designs is enhanced through strict manufacturing controls. Those controls result in closely matched sets that are a step above standard line series propellers. By utilizing a traditional design, Michigan Wheel can supply a vast range of sizes, at good value, with a minimal lead time.



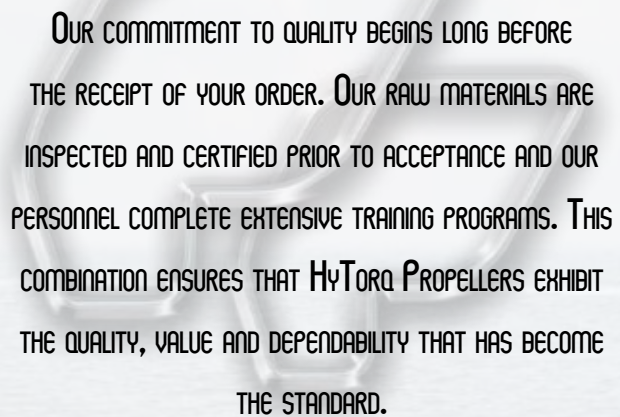

OUR COMMITMENT TO QUALITY BEGINS LONG BEFORE THE RECEIPT OF YOUR ORDER. OUR RAW MATERIALS ARE INSPECTED AND CERTIFIED PRIOR TO ACCEPTANCE AND OUR PERSONNEL COMPLETE EXTENSIVE TRAINING PROGRAMS. THIS COMBINATION ENSURES THAT **HyTORQ** PROPELLERS EXHIBIT THE QUALITY, VALUE AND DEPENDABILITY THAT HAS BECOME THE STANDARD.

HYTORQ PROPELLERS



Hy Torq 
Propellers

HYTORQ PROPELLERS

Available Alloys



In some engineering applications, there are times when standard product lines do not do the job. For these situations, Michigan Wheel Marine offers a complete custom design and manufacturing service. Whether or not your resulting propeller is CNC Machined or of our standard high quality hand finish, we will ensure you have a propeller suiting your needs.

HYTORQ PROPELLERS



MY-T3

The HyTorq MY-T3 is designed for both hard-working fishing boats and pleasure craft captains. Designed to handle today's high-powered engines with ease, the MY-T3 has a large blade area to enhance performance and maneuverability.



MY-T4

Manufactured to the same high quality standard as the HyTorq MY-T3, the MY-T4 is the right choice where greater blade area and super smooth operation are desired.



MY-T5

Many operators are selecting the HyTorq MY-T5 propellers for new construction, repowering, and propeller upgrading. The main reason is to employ more blade area without having to increase propeller diameter, which may not be possible due to clearance or tip speed considerations. Another common reason is to improve propeller performance in installations where heavy vee struts, dead wood, or other hull appendages are agitating the water flow to the propeller.

HyTORQ SPECIFICATIONS							HyTORQ MY-T3			HyTORQ MY-T4		
PROPELLER DIAMETER	AFT HUB DIAMETER	FORWARD HUB DIAMETER	HUB LENGTH	STANDARD TAPER BORE (INCHES)			WEIGHT (LB.)**	DEVELOPED AREA (IN ²)	WR ^{2**} (LB-IN ²)	WEIGHT (LB.)**	DEVELOPED AREA (IN ²)	WR ^{2**} (LB-IN ²)
				MINIMUM BORE	MAXIMUM BORE	PILOT BORE						
17	2-1/4	2-1/2	3-1/2	1-1/4	1-1/2	1-1/4	16	126.6	333	19	153.1	366
18	2-3/8	2-5/8	3-1/2	1-1/4	1-3/4	1-1/4	17	141.9	392	19	171.7	429
19	2-3/8	2-5/8	3-7/8	1-1/4	1-3/4	1-1/4	19	166.2	478	21	202.7	499
20	2-3/8	2-5/8	4	1-1/4	1-3/4	1-1/4	21	175.3	553	23	212.1	622
21	2-3/4	3	4-1/8	1-3/8	2	1-3/8	27	202.4	680	28	238.6	790
22	2-3/4	3	4-1/4	1-3/8	2	1-3/8	30	212.1	810	31	256.9	940
23	3-1/8	3-1/4	4-1/4	1-1/2	2	1-3/8	35	240.6	1,070	39	288.4	1,300
24	3-1/8	3-1/4	4-5/8	1-1/2	2	1-3/8	35	252.4	1,220	41	305.4	1,450
26	3-3/8	3-5/8	5	1-3/4	2-1/4	1-1/2	50	296.3	1,770	53	358.4	2,150
28	3-3/4	4	5-3/4	1-3/4	2-1/2	1-3/4	57	343.6	2,630	66	415.6	3,240
30	4	4-1/4	6	1-3/4	2-3/4	1-3/4	78	394.4	3,520	82	477.1	4,230
32	4-1/4	4-1/2	6	2	3	2	94	448.8	4,810	100	542.9	5,960
34	4-1/4	4-1/2	6-1/2	2	3	2	107	506.6	6,460	140	612.8	8,020
36	4-3/4	5-1/4	8-1/4	2-3/4	3-1/2	2-1/2	130	567.7	8,910	146	686.7	11,230
38	5-1/4	5-1/2	8-1/4	2-3/4	3-1/2	2-1/2	-	-	-	172	765.2	13,750
40	5-1/4	5-1/2	9	3	3-3/4	3	-	-	-	192	847.8	17,180
42	5-1/2	6	10-1/2	3	4	3	-	-	-	240	930.2	24,400
44	5-1/2	6-1/4	10-1/2	3	4	3	-	-	-	282	1,025.8	31,500
46	5-1/2	6-1/4	10-1/2	3	4	3	-	-	-	304	1,121.0	37,000
48	5-1/2	6-1/4	10-1/2	3	4	3	-	-	-	340	1,121.0	45,800

HyTORQ SPECIFICATIONS							HyTORQ MY-T5			
PROPELLER DIAMETER	AFT HUB DIAMETER	FORWARD HUB DIAMETER	HUB LENGTH	STANDARD TAPER BORE (INCHES)			WEIGHT (LB.)**	DEVELOPED AREA (IN ²)	WR ^{2**} (LB-IN ²)	
				MINIMUM BORE	MAXIMUM BORE	PILOT BORE				
24	3-1/8	3-1/4	4-5/8	1-1/2	2	1-3/8	57	384	1,990	
26	3-3/8	3-5/8	5	1-3/4	2-1/4	1-1/2	72	451	3,115	
28	3-3/4	4	5-3/4	1-3/4	2-1/2	1-3/4	79	523	3,967	
30	4	4-1/4	6	1-3/4	2-3/4	1-3/4	109	601	6,480	
32	4-1/4	4-1/2	6	2	3	2	150	683	8,847	
34	4-1/4	4-1/2	6-1/2	2	3	2	180	772	11,985	
36	4-3/4	5-1/4	8-1/4	2-3/4	3-1/2	2-1/2	210	864	15,676	
38	5-1/4	5-1/2	8-1/4	2-3/4	3-1/2	2-1/2	240	964	19,961	
40	5-1/4	5-1/2	9	3	3-3/4	3	260	1,068	23,961	
42	5-1/2	6	10-1/2	3	4	3	325	1,177	33,022	
44	5-1/2	6-1/4	10-1/2	3	4	3	370	1,291	41,260	
46	5-1/2	6-1/4	10-1/2	3	4	3	410	1,412	49,975	

EVOLUTION OF THE WHEEL

With over a century of history, despite several ownership and name changes, despite industry downturns and upturns, Michigan Wheel Marine has remained a reliable and dedicated supplier of marine propellers to the recreational and commercial marine industry.

Today, Michigan Wheel Marine offers tens of thousands of variations of propellers, and still retains its leadership position in original equipment and aftermarket propeller supply. The "Michigan" and "Federal" names are recognized and demanded world wide. Much credit goes to its loyal and supportive distributor and builder base, and its own dedicated employees. Our extensive history with marine propulsion has provided Michigan Wheel Marine with a solid foundation from which to continue meeting marine industry demands in the future.

HISTORY

Michigan Wheel Founded 1903
Michigan Wheel organized as a machine shop for the production of a variety of items, including marine propellers.



Propeller Concentration 1934
By 1934 the company's main activity was concentrated on the marine propeller field, concentrating on commercial vessel and industrial activity.



Hall & Stavert Founded 1934
Founded in 1934 as a two-man partnership, Hall & Stavert would grow to become the largest propeller manufacturer in Canada.



Federal Propellers 1949

Michigan Wheel Company purchased Federal Propellers, uniting the primary suppliers of recreational propellers. With a combined volume in production, Michigan Wheel Company is able to incorporate efficient manufacturing process.



War Years Growth 1940s

Real growth began with the war years, when military requirements demanded the "know-how" that Michigan Wheel had developed. After the war, recreational boating grew by leaps and bounds, and the Michigan Wheel Company was among the leaders in supplying propellers for a growth industry.



1900

1910

1920

1930

1940

1950





International Presence
1950s

Michigan Wheel expands marketing globally. Further develop international distributor network.



Michigan Wheel Corp.
1970s

In the 1970's, the Michigan Wheel Company becomes Michigan Wheel Corporation, and enters a period of acquisition to enhance the range of propeller product offered.



HyTorq Propellers
1997

Michigan Wheel acquires Canadian propeller competitor Hall & Stavert, manufacturer of the HyTorq Propeller line.



Michigan Wheel Marine
2009

Michigan Wheel Corporation is reorganized under new ownership as Michigan Wheel Marine.

Expansion
2010-2011

Michigan Wheel opens wholly owned facility in Dubai, United Arab Emirates. Acquires UK bearing manufacturer, Shearwater Marine, and introduces Aqualube to the American marketplace.



Sterndrive Propulsion
1960s

In the 1960's, Michigan Wheel Company kept pace with the industry in offering propellers for the then new sterndrive propulsion packages.



Automated Finishing
1980s

Automated finishing equipment for stainless steel propellers, and computer controlled milling machines gained favor, and Michigan Wheel Corporation is among the first to take advantage of such new technologies. Michigan's CAD-CAM abilities are unsurpassed in the ranks of propeller manufacturers.



GOLD Line
2005

Michigan Wheel - Europe launches a new range of quality inboard propellers - GOLD Line.

GOLD LINE

1960 1970 1980 1990 2000 2010



MANUFACTURING PROCESS

MICHIGAN WHEEL MARINE HAS ONE GOAL - TO PRODUCE THE FINEST PROPELLERS POSSIBLE, WHILE MAINTAINING THE HIGHEST STANDARDS OF QUALITY.

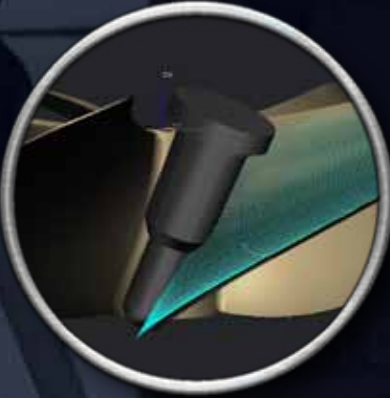

Michigan Propeller standard series offerings are available, affordable, and readily repairable. Stocking distributors throughout North American and Europe carry a wide variety of diameter and pitch ranges.



For immediate availability worldwide, Michigan Propellers a highly successful “field needs” service at no charge. This service locates a propeller in our distributors’ stock to meet a customer’s needs. Michigan Wheel Marine also has extensive experience in handling custom orders and in product export.



No matter the desired propeller, Michigan Wheel either has an existing design and casting pattern in its extensive inventory, or is able to design a brand new propeller and tooling needed, with custom specifications if necessary. High quality propeller castings are produced in Michigan Wheel special alloys by rigorously controlling the sand molding and metal melting processes. Propeller finishing is done by CNC high speed machining and experienced hand craftsmanship.

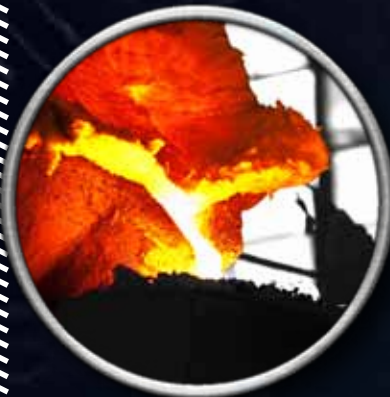

Modern, high quality, and specially designed equipment is used throughout the machining and finishing processes of Michigan Propellers. Through every step of the propeller manufacturing process, a variety of modern inspection equipment is used to carefully measure aspects of pitch, spacing and track. All propellers receive a final inspection to insure complete compliance with Michigan Wheel’s high tolerance specifications.





For decades, propeller repair facilities throughout North America, Europe, and other areas of the world have worked on Michigan Propellers. Authorized repair facilities have extensive knowledge on Michigan Wheel Marine's propeller designs and are experts at reconditioning and repair of Michigan Wheel Propellers. For your propeller service, be sure that the shop you choose is Michigan Wheel authorized; contact Michigan Wheel Marine for the location nearest you.



Photo Courtesy of Westport Yachts

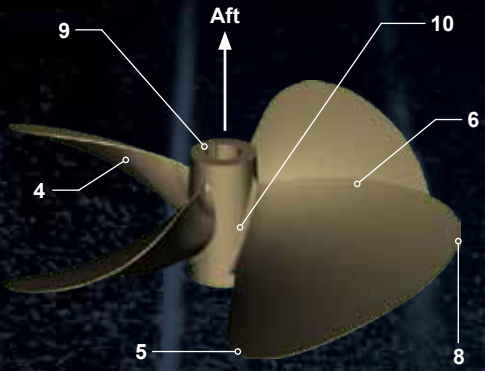

Photo Courtesy of Trinity Yachts LLC



Propeller Terms & Definitions

NO.	TERM	DEFINITION
1.	Diameter	The diameter of the imaginary circle scribed by the blade tips as the propeller rotates.
2.	Radius	The distance from the axis of rotation to the blade tip. The radius multiplied by two is equal to the diameter.
3.	Blade Face	Pressure side; Pitch side. Aft side of the blade (surface facing the stern).
4.	Blade Back	Suction side. Forward side of the blade (surface facing the bow).
5.	Leading Edge	The edge of the propeller blade adjacent to the forward end of the hub. When viewing the propeller from astern, this edge is furthest away. The leading edge leads into the flow when providing forward thrust.
6.	Trailing Edge	The edge of the propeller adjacent to the aft end of the hub. When viewing the propeller from astern, this edge is closest. The trailing edge retreats from the flow when providing forward thrust.
7.	Blade Number	Equal to the number of blades on the propeller.
8.	Blade Tip	Maximum reach of the blade from the center of the hub. Separates the leading and trailing edges.
9.	Hub	Solid cylinder located at the center of the propeller. Bored to accommodate the engine shaft. Hub shapes include cylindrical, conical, radius & barreled.
10.	Blade Root	Fillet area. The region of transition from the blade surfaces and edges to the hub periphery. The area where the blade attaches to the hub.
11.	Rotation	When viewed from the stern (facing forward): Right-Hand propellers rotate clockwise to provide forward thrust. Left-Hand propellers rotate counter-clockwise to provide forward thrust. (Right-Hand shown.)
12.	Pitch	The linear distance that a propeller would move in one revolution with no slippage.
13.	Cylindrical Section	A cross section of a blade cut by a circular cylinder whose centerline is the propeller axis of rotation.
14.	Pitch Reference Line	Reference line used to establish the geometric pitch angle for the section. This line may pass through the leading and trailing edges of the section and may be equivalent to the chord line.
15.	Geometric Pitch Angle	The angle between the pitch reference line and a line perpendicular to the propeller axis of rotation.
16.	Controllable Pitch Propeller	The propeller blades mount separately to the hub, each on an axis of rotation, allowing a change of pitch in the blades and thus the propeller.
17.	Fixed Pitch Propeller	The propeller blades are permanently mounted and do not allow a change in the propeller pitch.
18.	Constant Pitch Propeller	The propeller blades have the same value of pitch from root to tip and from leading edge to trailing edge.
19.	Variable Pitch Propeller	The propeller blades have sections designed with varying values of local face pitch to pitch.
20.	Rake	The fore or aft slant of a blade with respect to a line perpendicular to the propeller axis of rotation.
20a.	Aft Rake	Positive rake. Blade slants toward aft end of hub.
20b.	Forward Rake	Negative rake. Blade slants towards forward end of hub.
21.	Track	The absolute difference of the actual individual blade height distributions to the other blade height distributions. Always a positive value and represents the spread between individual blade height distributions.
22.	Skew	The transverse sweeping of a blade such that viewing the blades from fore or aft shows an asymmetrical shape.
22a.	Aft Skew	Positive skew. Blade sweep in direction opposite of rotation.
22b.	Forward Skew	Negative skew. Blade sweep in same direction as rotation.
23.	Cup	Small radius of curvature located on the trailing edge of blade.



7. Blade Number = 4

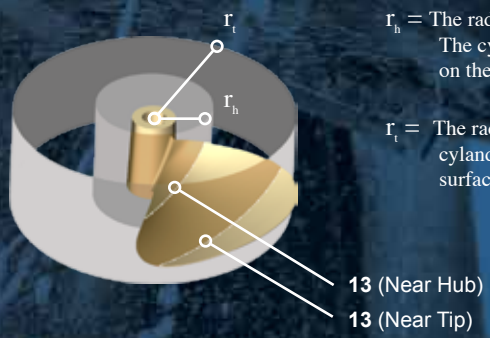
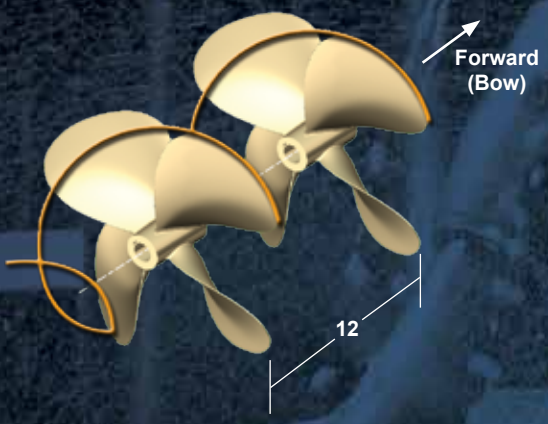
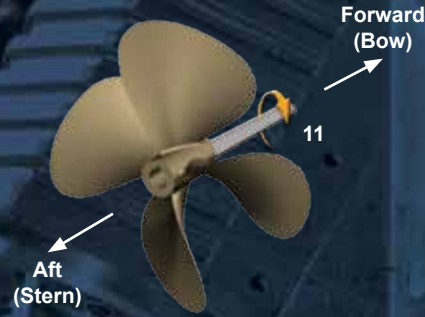

r_h = The radius of a cutting cylinder near the hub. The cylindrical section near the hub is located on the surface of this cylinder.

r_t = The radius of a cutting cylinder near the tip. The cylindrical section near the tip is located on the surface of this cylinder.

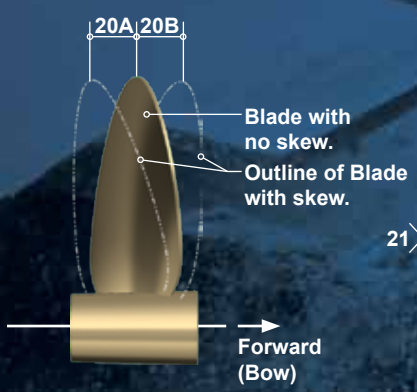
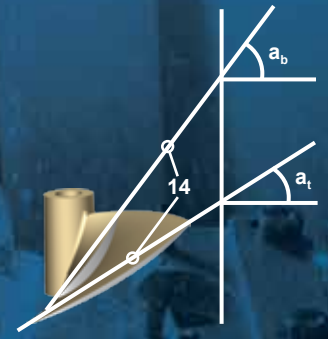
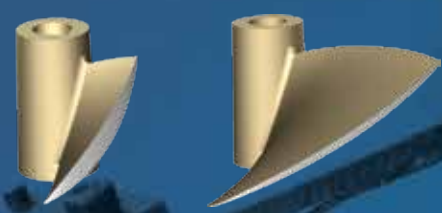
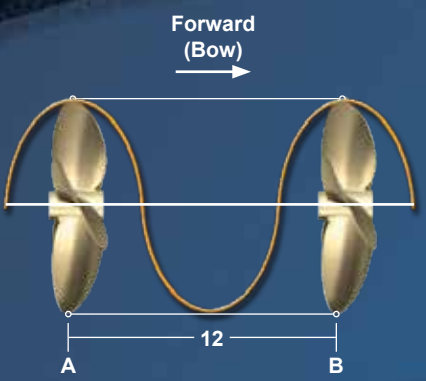

Blade with no skew.
Outline of Blade with skew.

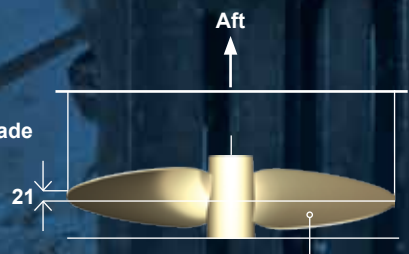

Blade with rake equal to the design rake

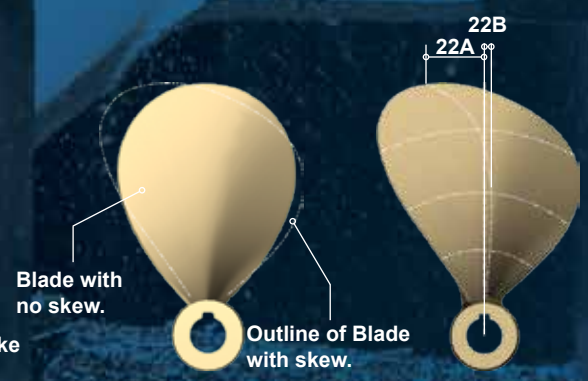

Blade with no skew.
Outline of Blade with skew.

INBOARD PROPELLER INSTALLATION PROCEDURES

1. Push propeller snugly onto shaft taper WITHOUT key in either keyway (propeller or shaft).
 2. Make sure the propeller is snug and there is no side to side movement by gently moving propeller back and forth.
 3. Make a line on the shaft with a non-graphite marker at the forward end of the propeller where it stops up against the shaft taper.
 4. Remove propeller.
 5. Put key into keyway on shaft taper with radiused or chamfered corners (down) in shaft keyway (if propeller shaft keyway has radiused corners.)
 6. Put propeller onto shaft taper.
 7. Check to see that the propeller moves back to the forward line made in Step 3. If it does, skip to Step 8. If not, perform the following:
 - a. Remove propeller from shaft.
 - b. Place a file on a flat surface area or work bench.
 - c. Run opposite end of chamfered key back and forth over file (to remove any burrs) with a downward pressure on key until side being filed is clean.
 - d. Install cleaned key in shaft keyway with chamfered corner side down in shaft (the cleaned, filed side up in keyway).
 - e. Replace the propeller on the shaft and fit snugly on taper. Check to see if it reaches the line made as in Step 7. If it does not line up, repeat Steps 7a through 7e.
- Note: A vise can be used to hold key and then filed, but care must be taken not to tighten too much, causing burrs and irregularities on key.**
8. When propeller hub moves to correct position, install propeller nut on shaft and torque to seat the propeller. Install the torque jam nut also, if your shaft is so equipped.
 9. Install cotter pin at end of the shaft.

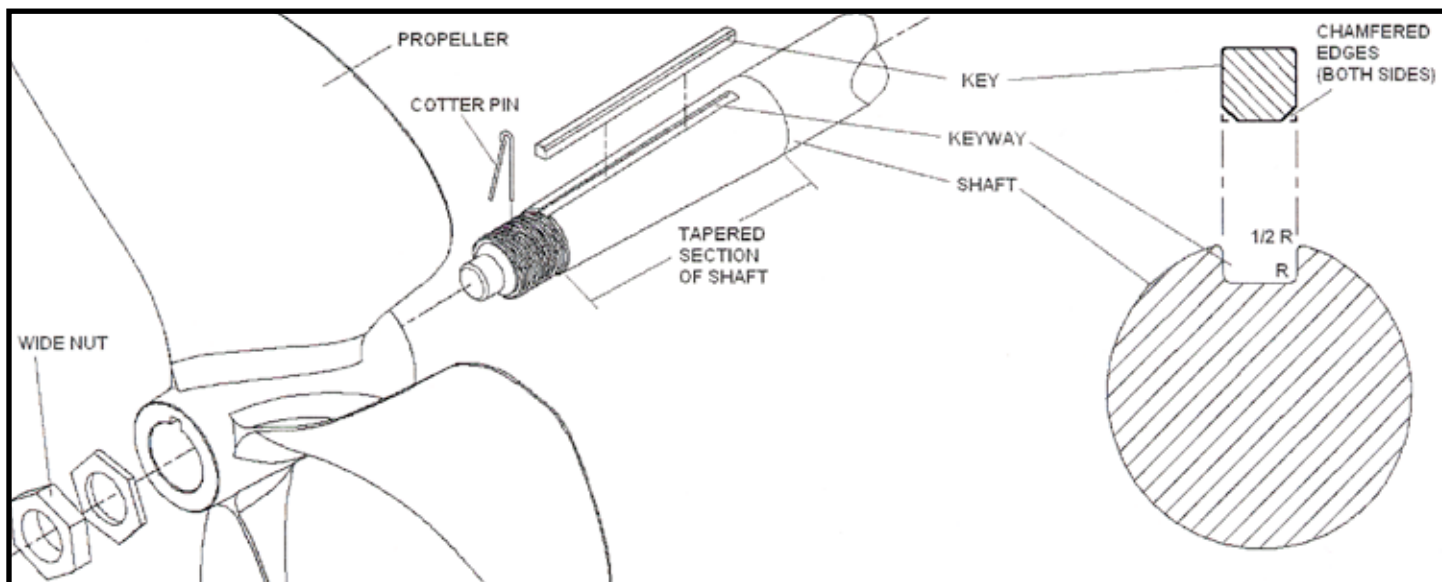

APPROVED S.A.E. STANDARD DIMENSIONS FOR SHAFTS 3/4 TO 3 INCHES IN DIAMETER

MARINE PROPELLER SHAFT END DIMENSIONS

Nom Shaft Diameter	Diameter Small End		Taper Length	Keyway Width			Keyway Side Depth			Keyway Fillet Radius (ii)	Thread (iii)		End of Taper to End of Thread	Ext. Beyond Taper	Undercut		Dia. of Pin End	Length of Pin End	Cotter-Pin Hole		Cotter-Pin		Nuts (iv)		Keyway Length		
	Min.	Max.		Min.	Max.	Min.	Max.	Min.	Max.		Min.	Max.			F	Tpi			J	K	Min.	Max.	N	(Drill) P		Q	Length
3/4	0.624	0.626	2	0.1865	0.1875	3/32	0.095	0.127	1/32	1/32	13	1-1/16	1-5/16	1/8	25/64	3/8	1/4	9/64	1/8	1/8	3/4	1/2	5/16	1/2	1-1/2	1-1/2	1-25/32
7/8	0.726	0.728	2	0.249	0.250	1/8	0.125	0.127	1/32	1/32	11	1-1/4	1-3/4	1/8	19/32	3/8	1/4	9/64	1/8	1/8	3/4	1/2	7/16	1/2	1-1/2	1-1/2	2-1/8
1	0.827	0.829	2-3/4	0.249	0.250	1/8	0.125	0.127	1/32	1/32	10	1-7/16	1-3/4	1/8	19/32	3/8	5/16	9/64	1/8	1/8	1	1/2	1-3/64	1/2	1-1/2	1-1/2	2-1/8
1-1/8	0.929	0.931	3-1/8	0.249	0.250	1/8	0.125	0.127	1/32	1/32	9	1-7/16	1-3/4	1/8	19/32	3/8	5/16	9/64	1/8	1/8	1	1/2	1-3/64	1/2	1-1/2	1-1/2	2-1/8
1-1/4	1.030	1.032	3-1/2	0.3115	0.3125	5/32	0.157	0.160	1/16	1/16	8	1-3/8	1-5/8	1/8	13/16	3/8	3/4	11/64	1/8	1/8	1	1/2	1-23/32	1/2	1-1/2	1-1/2	2-1/8
1-3/8	1.132	1.134	3-7/8	0.3115	0.3125	5/32	0.157	0.160	1/16	1/16	7	1-13/16	1-5/8	1/8	13/16	3/8	3/4	11/64	1/8	1/8	1	1/2	1-23/32	1/2	1-1/2	1-1/2	2-1/8
1-1/2	1.233	1.235	4-1/4	0.374	0.375	3/16	0.189	0.192	1/16	1/16	8	1-13/16	1-5/8	1/8	13/16	3/8	3/4	11/64	1/8	1/8	1	1/2	1-23/32	1/2	1-1/2	1-1/2	2-1/8
1-3/4	1.437	1.439	5	0.4365	0.4375	7/32	0.219	0.222	1/16	1/16	7	1-1/2	1-5/8	1/8	1-1/32	3/16	1/2	1-33/64	1/8	1/8	1	1/2	2-23/64	1/2	1-1/2	1-1/2	2-1/8
2	1.640	1.642	5-3/4	0.499	0.500	1/4	0.251	0.254	1/16	1/16	6	1-5/8	1-3/4	1/8	1-1/4	1/4	1/2	1-3/64	1/8	1/8	1	1/2	2-47/64	1/2	1-1/2	1-1/2	2-1/8
2-1/4	1.843	1.845	6-1/2	0.5610	0.5625	9/32	0.281	0.284	3/32	3/32	5	1-3/4	1-5/8	1/8	1-3/8	3/16	1/2	1-3/8	1/8	1/8	1	1/2	3-9/64	1/2	1-1/2	1-1/2	2-1/8
2-1/2	2.046	2.048	7-1/4	0.6235	0.625	5/16	0.312	0.315	3/32	3/32	5	1-3/4	1-5/8	1/8	1-3/8	3/16	1/2	1-3/8	1/8	1/8	1	1/2	3-9/64	1/2	1-1/2	1-1/2	2-1/8
2-3/4	2.254	2.259	7-7/8	0.6235	0.625	5/16	0.312	0.315	3/32	3/32	2	1-1/2	1-3/4	1/8	1-1/16	1/4	1/2	1-1/16	1/8	1/8	1	1/2	3-41/64	1/2	1-1/2	1-1/2	2-1/8
3	2.460	2.462	8-5/8	0.7485	0.750	3/16	0.311	0.314	3/32	3/32	2	1-1/2	1-3/4	1/8	1-1/16	1/4	1/2	1-1/16	1/8	1/8	1	1/2	3-41/64	1/2	1-1/2	1-1/2	2-1/8

DIMENSIONS OF SHAFTS FROM 3-1/4 TO 8 INCHES IN DIAMETER

Nom Shaft Diameter	Diameter Small End		Taper Length	Keyway Width			Keyway Side Depth			Keyway Fillet Radius	Thread		Ext. Beyond Taper	Undercut		Dia. of Pin End	Length of Pin End	Cotter-Pin Hole		Nuts		Sleeve Drive (v)	Clearance	Keyway Length	
	Min.	Max.		Min.	Max.	Min.	Max.	Min.	Max.		Min.	Max.		N	(Drill) P			Q	Length	Nom Dia.	Plain Thick				Jamb Thick
3-1/4	2.663	2.665	9-3/8	0.7185	0.750	5/16	0.311	0.314	1/8	1/8	4	4-3/8	5-1/8	2-1/8	3/8	3/4	3/8	3	2-1/2-4	2-1/2	2-1/2	1-1/2	3/8	3/8	8 1/2
3-1/2	2.866	2.868	10-1/8	0.8735	0.875	5/16	0.310	0.313	1/8	1/8	4	4-3/8	5-1/8	2-1/8	3/8	3/4	3/8	3	2-1/2-4	2-1/2	2-1/2	1-1/2	3/8	3/8	9 1/4
3-3/4	3.069	3.071	10-7/8	0.8735	0.875	5/16	0.310	0.313	1/8	1/8	4	4-3/4	5-1/2	2-3/8	3/8	3/4	3/8	3	2-3/4-4	2-3/4	2-3/4	1-5/8	3/8	3/8	10
4	3.272	3.274	11-5/8	0.9985	1.000	5/16	0.309	0.312	1/8	1/8	4	5-1/8	5-7/8	2-1/2	3/8	3/4	3/8	3	3-4	3-4	3-4	1-3/4	3/8	3/8	10 1/2
4-1/2	3.877	3.879	13-3/4	1.123	1.125	3/8	0.373	0.376	5/32	5/32	4	6-3/8	6-3/8	3-1/4	3/8	3/4	3/4	4	3-1/4-4	3-1/4	3-1/4	1-7/8	3/8	3/8	11 1/2
5	4.249	4.251	12	1.124	1.125	3/8	0.373	0.376	5/32	5/32	4	6-3/8	6-3/8	3-1/4	3/8	3/4	3/4	4	3-3/4-4	3-3/4	3-3/4	2-1/8	3/8	3/8	12 1/2
5-1/2	4.671	4.673	13-1/4	1.248	1.250	7/16	0.435	0.438	3/16	3/16	4	6-3/4	7-3/4	3-1/2	1/2	1/2	1/2	1/2	4-4	4-4	4-4	2-1/4	3/8	3/8	13 1/4
*6	4.791	4.793	14-1/2	1.373	1.375	1/2	0.493	0.496	7/32	7/32	4	7-1/2	8-1/2	3-7/8	1/2	1/2	1/2	1/2	4-1/4-4	4-1/4	4-1/4	2-1/4	3/8	3/8	14 1/4
*6 1/2	5.187	5.189	15-3/4	1.373	1.375	1/2	0.494	0.497	7/32	7/32	4	8-1/4	9-1/4	4-3/8	1/2	1/2	1/2	1/2	4-1/2-4	4-1/2	4-1/2	2-1/2	3/8	3/8	14 3/8
*7	5.582	5.584	17	1.498	1.500	9/16	0.555	0.558	1/4	1/4	5	9	10	4-7/8	1/2	1/2	1/2	1/2	5-4	5	5	2-3/4	3/8	3/8	15 5/8
*7 1/2	5.978	5.980	18-1/4	1.498	1.500	9/16	0.556	0.559	1/4	1/4	4	9-3/8	10-3/8	5-1/8	1/2	1/2	1/2	1/2	5-1/2-4	5-1/2	5-1/2	3-1/8	3/8	3/8	16 1/8
*8	6.374	6.376	19-1/2	1.748	1.750	9/16	0.555	0.556	1/4	1/4	4	9-3/4	10-3/4	5-3/8	1/2	1/2	1/2	1/2	5-3/4-4	5-3/4	5-3/4	3-1/8	3/8	3/8	18-1/8

* 6" through 8" shaft has 1 inch per foot taper; 1/12" per inch taper. Angle with centerline is 2° 23' 9".

(i) Fillets are recommended for keyways in shafts through 2" in diameter. Fillets are mandatory for shafts above 2" in diameter.

(ii) Keyway shall be cut parallel to taper.

(iii) Threads are Unified and American Standard, Class 3A.

(iv) Nuts are to be semi-finished stock, American Standard B18.2.

(v) The shaft sleeve shown is recommended practice, but the use of a sleeve is optional.

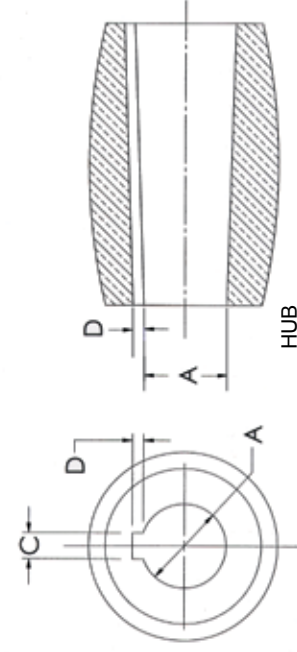

PROPELLER BORING
To insure retention of inherent factory accuracy, order your propeller factory-bored whenever possible. When bored in the field, propellers should be bored to the pilot hole, NOT to the hub or blade edges.

*6" through 8" shaft has 1 inch per foot taper, 1/12" per inch taper. Angle with centerline is 2° 23' 9". Overseas specifications on request.

Std. Taper	Dia. Small End		Keyway Width		Keyway Side Depth	
	Min.	Max.	Min.	Max.	Min.	Max.
3/4	0.608	0.610	0.1865	0.1875	3/32	0.098
7/8	0.710	0.712	0.249	0.250	1/8	0.130
1	0.812	0.814	0.249	0.250	1/8	0.130
1-1/8	0.914	0.915	0.249	0.250	1/8	0.130
1-1/4	1.015	1.017	0.3115	0.3125	5/32	0.165
1-3/8	1.118	1.118	0.3115	0.3125	5/32	0.165
1-1/2	1.218	1.220	0.374	0.375	3/16	0.195
1-3/4	1.421	1.423	0.4365	0.4375	7/32	0.226
2	1.624	1.626	0.499	0.500	1/4	0.259
2-1/2	1.827	1.829	0.561	0.5625	9/32	0.291
2-3/4	2.030	2.032	0.6235	0.625	5/16	0.322
3	2.233	2.235	0.6855	0.6875	3/8	0.353
3-1/4	2.437	2.439	0.7485	0.750	7/16	0.384
3-1/2	2.640	2.642	0.8115	0.8125	1/2	0.415
3-3/4	2.843	2.845	0.8735	0.875	5/16	0.446
4	3.046	3.048	0.9355	0.9375	3/8	0.477
4-1/2	3.249	3.251	1.0975	1.099	7/16	0.508
5	3.452	3.454	1.2595	1.261	1/2	0.539
5-1/2	3.655	3.657	1.4215	1.423	9/16	0.570
*6 1/2	3.858	3.860	1.5835	1.585	5/8	0.601
*7	4.061	4.063	1.7455	1.747	3/4	0.632
*7 1/2	4.264	4.266	1.9075	1.909	7/8	0.663
*8	4.467	4.469	2.0695	2.071	1	0.694

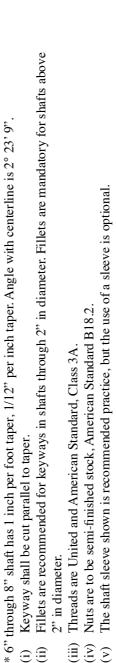

0.03 X 45°
P DRILL
HUB
COTTER PIN
F Thd

PROP-IT-RIGHT ANALYSIS

Type of Analysis: <input type="checkbox"/> New Construction <input type="checkbox"/> Evaluation <input type="checkbox"/> Repower	Name: _____ Company: _____ Address: _____ City/State: _____ Zip/Country: _____ Phone: _____ Fax: _____ E-mail: _____ Date: _____
VESSEL INFORMATION	
Manufacturer: _____ Model: _____ Year: _____ Boat Use: <input type="checkbox"/> Work/Commercial <input type="checkbox"/> Towing <input type="checkbox"/> Pleasure Hull Type: <input type="checkbox"/> Semi-Displacement <input type="checkbox"/> Displacement <input type="checkbox"/> Planing Bottom Design: <input type="checkbox"/> Open <input type="checkbox"/> Tunnel <input type="checkbox"/> Pocket Hull Material: <input type="checkbox"/> Fiberglass <input type="checkbox"/> Wood <input type="checkbox"/> Aluminum	

1. Vessel Data

Overall Length: _____ Loaded Weight: _____ Expected Top Speed: _____
 Waterline Length: _____ Beam: _____ Draft: _____

All Engine Data Must Be Completed.

2. Current or New Engine Data*

Manufacturer: _____ Model: _____ Year: _____
 Maximum Engine Rating: Brake _____ HP @ _____ RPM or Shaft _____ HP @ _____ RPM
 Gear Reduction Ratio: _____ :1 Fuel Type: Gas Diesel Other _____
 Number of Engines: Single Twin Triple Other _____

If no propeller size or performance data available, section 1 must be completed in detail.

Current Performance: Full Throttle (Wide-open) Engine RPM _____ RPM (Actual tachometer reading)
 Full Throttle (Wide-open) Vessel Speed _____ MPH Knots (Actual speedometer/GPS reading)

* If re-power, fill in the above with **NEW** engine data. Refer to the Section 3 for current propeller data and Section 4 for **OLD** engine information.

3. Current Propeller Data

Manufacturer: _____ Model/Style: _____ Material: Bronze Nibral Stainless Steel
 Propeller Size: Diameter _____ x Pitch _____ Number of Blades: _____

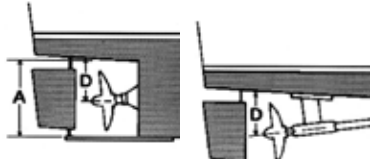

Maximum Propeller Diameter: _____
 OR
 Shaft to Hull Distance: D = _____

Shaft: SAE Metric Size: _____

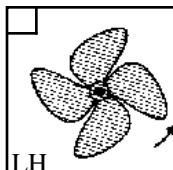

LH

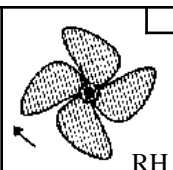

RH

Rotation:
Check one or both.

*Viewed from
behind the boat.*

4. Re-power Data (Old Engine Information)

Manufacturer: _____ Model: _____ Year: _____
 Maximum Engine Rating: Brake _____ HP @ _____ RPM or Shaft _____ HP @ _____ RPM
 Gear Reduction Ratio: _____ :1 Fuel Type: Gas Diesel Other _____
 Number of Engines: Single Twin Triple Other _____
 Old Performance: Full Throttle (Wide-open) Engine RPM _____ RPM (Actual tachometer reading)
 Full Throttle (Wide-open) Vessel Speed _____ MPH Knots (Actual speedometer/GPS reading)

5. Vessel/Propeller/Nozzle Certification Required

ABS Lloyds DNV Other

Propeller Application: Open Nozzle

If nozzle, please fill in this section.
 Write in your dimensions here:

A. _____
 B. _____
 C. _____
 D. _____

Comments: _____

Note: The propeller suggestion can only be as accurate as the information that you provide.

ALSO AVAILABLE FROM MICHIGAN WHEEL

FOR MORE INFORMATION, VISIT WWW.MIWHEEL.COM.

HIGH PERFORMANCE WATER-LUBRICATED BEARINGS

High quality rubber sleeved bearings designed for marine and industrial applications, with tolerance suited for American shaft and strut standards.

www.miwheel.com/propellers/inboard/aqualube-bearings



ECONOMICALLY ADVANTAGEOUS STANDARD SERIES

Globally sourced, economically advantageous standard series propeller line, manufactured to Michigan Wheel tolerance and hub dimensional standards.

www.miwheel.com/propellers/inboard/michigan-propellers

COMPUTERIZED 3D PROP MEASUREMENT DEVICE

Provides absolute recognition of propeller condition and extremely precise 3D data, including measurements of: pitch; rake; track; spacing; geometry and camber of any propeller.

www.miwheel.com/propellers/inboard/hale-mri



Michigan Wheel Marine

World Headquarters
1501 Buchanan Avenue Southwest
Grand Rapids, MI 49507
United States

Toll-Free: 1-800-369-4335
Phone: 1-616-452-6941
Fax: 1-616-247-0227

info@miwheel.com
www.miwheel.com



Europe Headquarters
Unit C1 B, Pottery Road
Newton Abbot, Devon TQ12 3BN
United Kingdom

Phone: +44 1626 351723
Fax: +44 1626 351724

sales@miwheel-europe.com
www.miwheel-europe.com



Middle East • Africa • Asia Headquarters
P.O. Box 54805, DY-1, Show Room No. 7
Al Jadaf Ship Docking Yard, Dubai
United Arab Emirates

Phone: +971 4 3243867
Fax: +971 4 3243868

sales@miwheel-meaa.com
www.miwheel-meaa.com



© 2012 MICHIGAN WHEEL MARINE
PRINTED IN THE USA. JANUARY 2012
ALL RIGHTS RESERVED.

PART NUMBER 99022512
REV G (6-14-13)