



THE ROPE HANDLING
REVOLUTION

2020



OUR PHILOSOPHY: SAFER, LIGHTER, MORE EFFICIENT

Harken Industrial's sailing heritage is key to our load handling and rope access innovations. Other manufacturers typically increase load-bearing capacity and safety by adding more and heavier materials. Redundancy increases this weight even more. Workers take risks and expend energy just to move, deploy, and operate oversized equipment.

This strategy is impossible in sailing. Faster speeds and larger sails have exponentially increased the loads on modern yachts, but users still demand products that are safe, lightweight, resistant to UV light and corrosive conditions, and easy to use. Friction reduction is critical when small teams need to move huge loads. Wire rope has almost disappeared from the modern yacht, now replaced with fiber ropes that are 15 times stronger than steel wire by weight.

Harken Industrial's kindred approach of taking the weight, friction, and effort out of operations means equipment is more mobile, workers are safer and more agile, and companies can complete jobs with smaller teams. Fiber rope is far easier to carry and far easier to handle for both humans and equipment. Lighter and more efficient equipment reduces strain on anchor points and improves alignment with loads. These advantages translate into huge safety increases and major benefits to the bottom line for industrial riggers, utility companies, and teams that work at height.

The ease of handling and elegant simplicity also lends an incredible amount of flexibility to our products. Harken Industrial has designed pulleys for hauling aircraft, and a winch system for handling heavy loads at height to eliminate the need for a crane. Even our gas-powered Harken PowerSeat® ascender is light enough to carry for rescue applications, yet robust enough to handle everyday utility maintenance with ease. We are always up for a challenge, looking for ways to improve working conditions, and pushing ourselves as hard as we push our products.

A Lasting Partnership

At Harken Industrial, we build more than products, we build relationships. When you partner with us you gain access to world-renowned service, two state-of-the-art manufacturing facilities in the US and Italy, in-house testing facilities for loads up to 100 tons, and professionals with decades of experience designing products that stand up to the harshest conditions. Our team offers sales and support from 11 offices around the world and is backed by a wide distributor network. At Harken Industrial, we value our next project with you as much as our first, so we dedicate ourselves to making sure you are satisfied with both the process and the end product.

Contact us today to create a solution together.

APPLICATIONS

TABLE OF CONTENTS

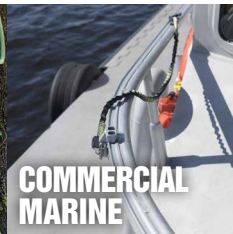

4 Materials & Properties

6 Testing & Manufacturing

7 Training & Support

8 Rope Travel Devices

Clutch Descender	●		●	
Ninja Foot Ascender	●		●	
PowerSeat Ascenders	●	●	●	

18 Powered & Manual Winches

LokHead Winches	●	●	●	●
LokHead Power Haulers (PowerSeat-Compact)	●	●	●	
Rigging Winches	●	●	●	●
High Capacity Drum Rigging Winches			●	

30 Rails & Trolleys

Access Rail	●	●		●
Long Span Access Rail	●	●		●
TR31 Tight Radius System				●
Trolley & Rail Systems				●
Adjustable Seat Rail Systems				●

50 Pulleys

EN13157 Pulleys	●		●	●
Purchase Systems	●	●		●
Oceanic Cable Blocks				●

58 Marine Rescue Systems

C-Hero Rescue Davit & Pole System				●
C-Hero VR-12 Pole with Recovery Strap				●

63 Accessories

Static Attachments		●		●
Ball Bearing Cam Cleats				●

66 Professional Warranty

68 Contacts

MATERIALS & PROPERTIES

Aluminum

6061-T6: an aluminum alloy that has excellent corrosion resistance to air and salt water. It is an easily welded, tough alloy that responds well to anodizing.

Bearings

Bearing properties are functions of contact area, material type, bearing cages, and whether the bearing rolls or slides.

Types: Ball bearings: very low-friction; low/medium-load capacity.

Roller bearings: low-friction; high-load capacity.

Sleeve bearings: medium/high-friction; extremely high-load capacity.

Materials: Stainless steel is stronger than Torlon® thermoplastic and Torlon is stronger than Delrin® acetal resin. Because stainless is heavier and usually higher maintenance, Torlon is used in most high-load applications.

Contact Area: More contact between the bearing and the race increases friction, but also increases load capacity. Balls are loaded on small points, cylindrical rollers are loaded along their length, and sleeve bearings are curved around the shaft so a large portion is in contact. Unlike balls and cylinders, sleeves are not prone to being flattened by extreme or static loads because they already conform to the curvature of the shaft.

Motion (rolling, caged rolling, or sliding): Sliding bearings (known as sleeve, plain, full-contact, bushing, or journal bearings) are very high strength but have nothing to reduce friction between contact areas. At most, they have a low-friction sleeve between the surfaces. Rollers and balls avoid almost all of this friction because they do not slide against the race, though they can come in contact with each other. Caged roller bearings are separated from each other to avoid this.

Caged bearings

Caged bearings are roller bearings held in a cage that keeps them separated from each other and parallel to reduce friction. Caged bearings are used in winches and Black Magic pulleys.

Captive bearings

Captive bearings are ball bearings that are contained so they won't spill during product maintenance. Black Magic pulleys have ball bearings held captive by the lip of the sheave. CB trolleys feature ball bearings held captive by a wire guide.

Carbo

Carbo® Air® pulleys feature lightweight, fiber-reinforced, nylon-resin sideplates with a 60% higher MWL than stainless-reinforced Classic pulleys. Lightweight fiber-reinforced Carbo-Cams are ideal for applications where weight is critical. The Carbo name comes from an additive that gives pulleys their color and UV-resistance.

Carbon black

Carbon black is a color additive used in black Delrin ball bearings, block sheaves, and sideplates to protect against UV exposure.

Delrin is a registered trademark of E. I. du Pont de Nemours and Company or its affiliates.

Torlon is a registered trademark of Solvay Advanced Polymers, L.C.C.

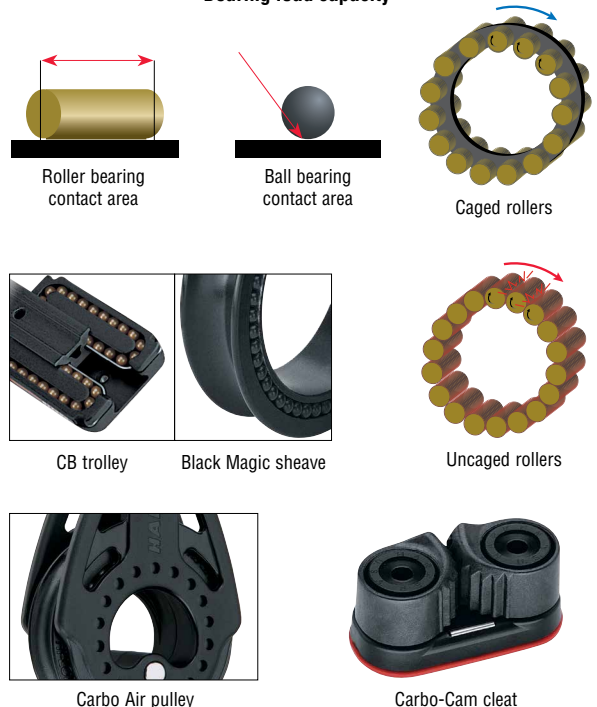
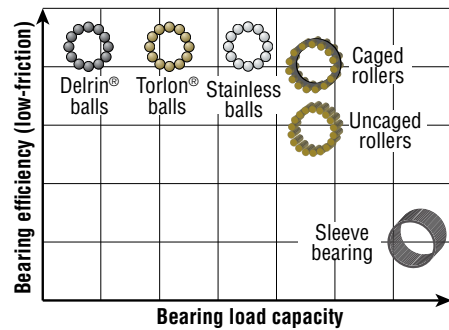



Clear-anodized

Clear aluminum anodizing is an electrochemical process that produces a corrosion-resistant finish. It also hardens the surface, making components less prone to scratches and dents. It is “clear” because the protective layer isn’t thick enough to change the color of the component (though dye can be added). More rigorous anodizing, such as hardcoat, can give components a black or colored hue.

Delrin® acetal resin

Delrin® acetal resin excels in low to moderate-load applications. It is used for bearings, sheaves, and sideplates in smaller pulleys.

Hardcoat-anodized

Hardcoat aluminum anodizing is an electrochemical process that produces a corrosion-resistant finish with hardness characteristics second only to diamonds. Harken Industrial’s hardcoating process is twice as thick as black anodizing to provide extra protection against scratches, dents, superficial deformation, and corrosion.

Hard lube-anodized

Hard Lube-anodized aluminum includes all the corrosion-resistant properties of hardcoat-anodized aluminum with the additional benefits of a PTFE coating for a smoother surface and reduced friction.

Nylatron® nylon

Durable, lightweight composite material that has high mechanical strength and stiffness, resists static electricity, and has excellent wear resistance.

PTFE-coated

PTFE-coating, along with anodizing, protects aluminum against corrosion by sealing the surface from moisture. It also minimizes friction and gives the component better wear resistance.

Stainless steel

17-4 PH Stainless Steel: this alloy is used in gears because it is hardenable to extremely high strengths. 17-4 PH is more corrosion-resistant than any other standard hardenable stainless steel.

316 Stainless Steel: this is a nonhardenable alloy with high corrosion resistance in freshwater and saltwater.

Torlon® thermoplastic

Exceptionally strong crush/impact-resistant bearing material that withstands heavy long-term use and shock loading. Most Harken Industrial hardware that sees extreme loads uses greenish-brown Torlon® bearings.

UV-stabilized

UV light photo-degrades composites by breaking their chemical bonds, leaving them weak, brittle, and discolored. This is common in equipment with white bearings. All Harken Industrial composites and bearings are naturally UV-resistant or use stabilizers like carbon black.

Delrin is a registered trademark of E. I. du Pont de Nemours and Company or its affiliates.
 Nylatron is a registered trademark of Quadrant EPP USA Inc.
 Torlon is a registered trademark of Solvay Advanced Polymers, L.C.C.

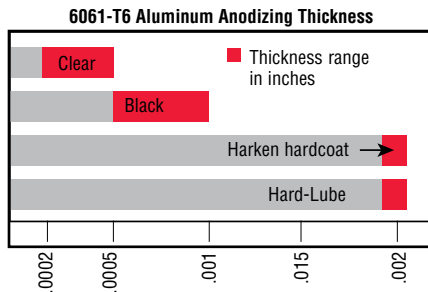

TESTING & MANUFACTURING

Working with Harken Industrial...

puts over 80,000 square meters of manufacturing capacity and a commitment to our own product testing to work for you. Harken Industrial products are designed to perform and reduce your risk while on the job.

Testing

Harken Industrial prides itself on delivering products that offer unprecedented performance with appropriate safety margins. Prior to delivery, these products must be tested to meet regulatory standards set by product type.

Harken Industrial has built comprehensive in-house testing capabilities into both our major manufacturing facilities— one in Pewaukee, Wisconsin, USA and one in Limido Comasco, Italy. Using industry-standard software, we perform relevant product cycling tests for durability. We routinely load-capacity test our industrial pulleys. We execute fall-arrest testing on our human suspension working-at-height products to meet applicable EN regulations today and ANSI in the future.

Our testing capabilities evolve as new products are developed. In response to the design of a new fiber rope captive winch with a 686 kN working load, we built a 20-meter, 25,000 kg test bench to test that winch, and winches we anticipate will have capacities up to 100 tons.

Manufacturing

Our manufacturing facilities in USA and Italy total approximately 80,000 sq. m (250,000 sq. ft.) and produce a substantial majority of all the products we sell. Here you'll find industrial-scale metal stamping, lathing, milling, cutting, and injection-molding machinery. We have advanced composite and carbon-fiber capabilities, welding expertise in stainless steel, aluminum, and titanium, and have invested in scalable hydraulics production. In addition, our U.S. industrial fabric cutting and sewing team creates seating for our human-suspension products, and cuts prepreg carbon fiber for some high-performance pulleys. Our product assembly, packaging, and shipping functions are only steps from production for increased speed and inventory efficiency. Our U.S. Headquarters and Harken Italy are ISO 9001:2015 Certified.



TRAINING & SUPPORT

Our Global Network...

provides service and support before and after each sale. We also provide training and consulting in application, safety and equipment usage to help ensure jobs are done safely and efficiently.

Training

Harken Industrial™ ensures its products are correctly specified and safely installed by an international network of trained distributors. This team is regularly updated on new product capabilities, capacities, and safety requirements. They are also involved in solving installation challenges and product maintenance issues.

Elevated Safety (elevatedsafety.com), a Harken Industrial company, provides training and consulting services in industrial rope access and rescue. Those services include training in working at height, confined space access and rescue, fire rescue and SPRAT certification. In addition to Elevated Safety, Harken Industrial has a growing network of official training partners around the world including Safety Work Services (safetyworkservices.com) in Peschiera Borromeo, Italy.

The result is an experienced and informed team of product and training experts prepared to transfer knowledge and skills to our customers.

Service & support

The professionals on the Harken Industrial Customer Service and Technical Support teams pride themselves on their high levels of preparedness and experience. It takes almost a full year before a Technical Support Specialist is allowed to take the lead on a customer's request unsupervised.

Beyond the human component in our support structure, you'll find a rich assortment of product manuals/drawing files, and application templates on our website, harkenindustrial.com.

Product Certifications

PRODUCT	CERTIFICATION	APPLICATION
Access Rail Long Span Access Rail	CE EN795:2012 Type B certified (trolleys); EN795:2012 Type D and CEN/TS 16415:2013 compliant (rails) UNI11578:2015 certified	Fall arrest/Fall restraint Human suspension
CLUTCH	EN 12841:2006/C certified EN 341:2001/2A certified EN 15151-1: 2012/8 certified ANSI/ASSE Z359.4-2013 NFPA 1983 (2017 ED)	Lifting persons + Lifting objects
LokHead Winch Kit	CE EN 13157:2009 certified CE EN 1496:2007 class B compliant	Lifting persons + Lifting objects
LokHead Winch Kit Fire/Rescue	Meets the NFPA Standard on Life Safety Rope and Equipment for Emergency Services NFPA 1983 (2017 ED) "T"	Lifting persons + Lifting objects
PowerSeat LokHead Power Hauler (PowerSeat Compact)	CE 2006/42/CE Machine Directive certified Independently verified by Bureau Veritas	Lifting persons + Lifting objects
Pulleys/Purchase Systems	CE EN13157:2009 certified	Lifting objects
Rigging Winch 500	CE EN 13157:2009 certified	Lifting objects
Padeyes	CE EN 795:2012 Type A compliant ANSI Z359.1	Fall arrest/Fall restraint Human suspension
TR31	EN795:2012 Type D compliant ANSI Z359 OSHA compliant	Fall arrest/Fall restraint

ROPE TRAVEL DEVICES



Rope-access and load-handling equipment from Harken Industrial has been designed in collaboration with field-experienced experts to improve safety and enhance productivity.



“ **THE CLUTCH HAS ALLOWED OUR TEAM TO REPLACE THREE DEVICES WITH ONE** by its ability to lower and raise heavy loads along with its comparatively smaller size. It has reduced our

financial expenditures in equipment and training time. CLUTCH’s ability to be used in both Rope Access and Rescue has simplified and streamlined our training and operational programs.

— Mark Pfeifer, President & CEO, Ronin Safety & Rescue ”

XCMC™ CLUTCH™

by **HARKEN** INDUSTRIAL

A multi-purpose rope travel device engineered to assure rescuers and access professionals are prepared for the most situations possible

CLUTCH reduces the effort required for hauling, descent, ascent, and progress capture operations

The versatile CMC™ CLUTCH™ by Harken Industrial™ is a single wearable tool suited for efficient hauling, controlled lowering, smooth personal descent, easy ascending, and reliable progress capture. Not only does it replace the hardware used in a traditional raise/lower system for rescue operations, it also serves as a personal descender with the most efficient ascending capability of any product in its class. The CLUTCH

enables more rope operations with one tool than anything we've ever evaluated.

The CLUTCH is the result of the design and product engineering collaboration by two experts with a collective 90 year history in rope management under heavy loads; CMC, a company with roots in rescue and rope access and Harken Industrial, a manufacturing company with roots in high-performance sailing.

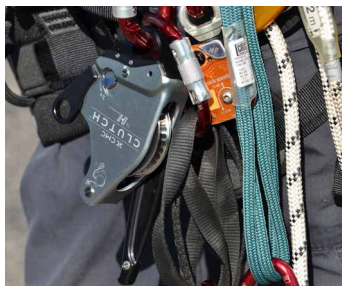

Unmatched preparedness and value

The CLUTCH combines the attributes of more expensive multipurpose devices with those of less sophisticated wearable personal descenders. Rescue teams can carry less equipment while assuring they're prepared for even the most technical rescues.

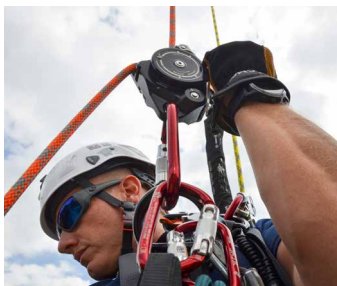

More refined descents

The patented mechanical geometry inside CLUTCH and its ergonomic handle, combine for better control across the load range in descent.



Efficiency that improves performance

CLUTCH features a faceted ratcheting sheave of stainless steel that provides secure rope holding and audible progress capture. It also proves to be uncommonly efficient on ascent or haul.



CE Certified

The CMC CLUTCH by Harken Industrial is certified under EN 12841:2006/C, EN 341:2001/2A, EN 15151-1: 2012/8, ANSI/ASSE Z359.4-2013 and NFPA 1983 (2017 ED).



Designed to be intuitive—and safe

CLUTCH is designed for efficient operation, ease of use and optimal control. Its innovative double-latched side plate is independent of the device's attachment point and resists inadvertent opening. Rescuers and access professionals can change rope without disconnecting.

FAST FACTS

The CLUTCH is certified

The only 10.5-11mm rope diameter compatible device certified to NFPA 1983 (G-Rated), ANSI Z359.4 and EN 12841/C, 341/2A, and 15151/8 (up to 200m/240kg).

CLUTCH is also an ascender

It has been called the best ascending descender on the market. Technicians report not having to change out equipment in the middle of an operation.

CLUTCH incorporates advanced security features

Its opening side plate is secured with a patented, two-step safety actuation. CLUTCH has a force-limiting sheave for overload protection. An Anti-panic function automatically locks the device during descent if the handle is pulled too far.

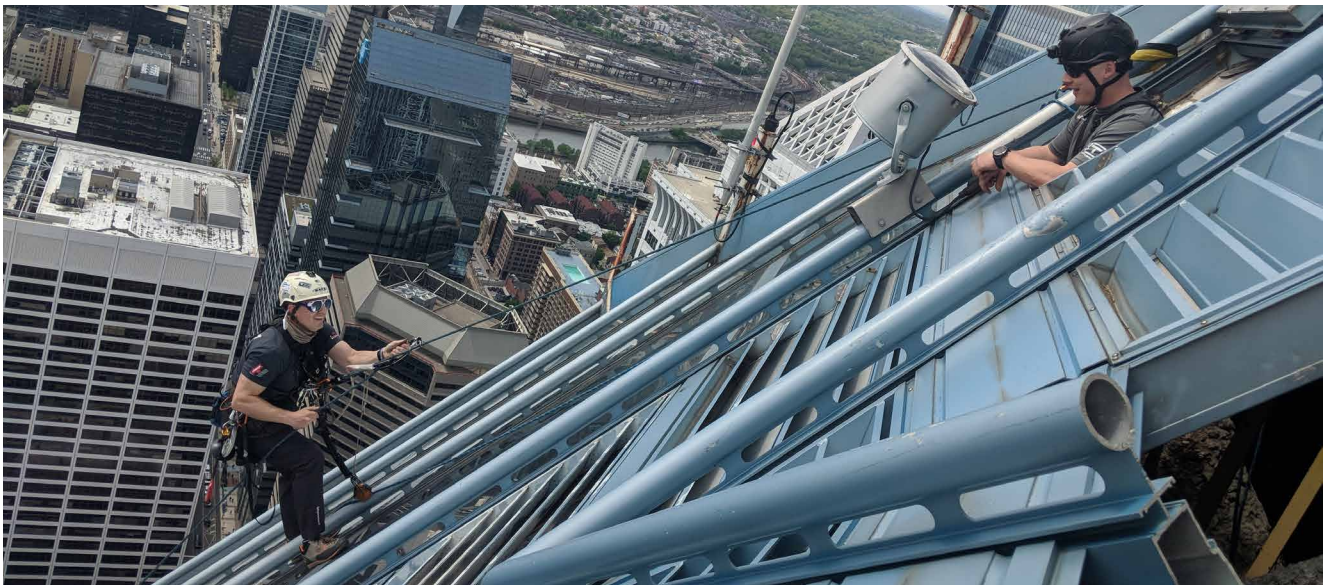

Part No.	Description	Rope Ø		Width	Height	Weight		Maximum rated load 2-person				
		in	mm			in	mm		lb	kg		
IN401	CMC CLUTCH by Harken Industrial	13/32	10.5	7/16	11	4 13/32	112	8 1/32	204	1.85	0.84	Refer to manual for specific load rating per standard



WARNINGS AND INSTRUCTIONS. You must carefully read, understand, and follow all of the warnings and instructions in the manual provided by Harken Industrial in order to avoid an accident. Never, under any circumstances, exceed the maximum rated load.

ninja™

FOOT ASCENDER

Speeds up arborist, rescue, and rope access operations

Climb rope quickly and easily



Climbing rope has never been easier. The Ninja™ foot ascender from Harken Industrial™ is lightweight and durable. The housing is aluminum and the rope-holding dual cams are stainless steel. Foot ascenders use your body's largest

muscle group to ascend a rope easily and quickly. The Ninja has a maximum rated load of 1.5 kN (330 lb) and can handle rope up to 13 mm (1/2"). The Ninja is the only foot ascender that can be used on either foot.



Increased productivity

The Ninja is designed with springs that reduce rope drag to the lowest of any available foot ascender. This means that there is a smoother and easier take off without having to counterweight the rope or reach down to pull the rope through the unit. The result? Increased worker productivity.



Won't damage your rope

The Ninja uses a transverse ribbed cam instead of teeth. Competitive designs rely on aggressive barbs on their single cams, which can damage rope cover.



Innovative design

Dual cam system (based on Harken's marine Cam-Matic® ball bearing cleats) applies pressure to both sides of the rope simultaneously. This provides more thorough and even force than competitive designs whose cams act on just one side of the rope against a fixed wall on the other side. It also prevents accidental kick-outs.

Keep your Ninja clean and free-running by frequently flushing with fresh water. Periodically clean with mild detergent and water solution. Rotate cams to distribute soap solution evenly.

Part No.	Description	Rope Ø		Width	Height	Weight	Max rated load		Cam material	Housing material					
		in	mm				in	mm			lb	kN			
IN400	Ninja foot ascender	5/16	8	1/2	13	3.3	83	2.9	74	6.3	178	330	1.5	Stainless steel	Aluminum





POWERSEAT®

Taking the work out of working at height

Revolutionary device for working at height

The unique Harken Industrial™ PowerSeat® ascender has revolutionized working at height, allowing the operator to ascend quickly, stay in position longer, and work comfortably. The PowerSeat is the best solution for completing a job on time. Harken Industrial PowerSeats are comfortable sit-on powered ascenders and manual friction-brake descenders

designed for use by rope-access and rescue operators working at height. Strong and lightweight, these portable ascenders allow workers to get to the job quickly and work comfortably for longer periods of time. Most importantly, safety is greatly enhanced through a significant reduction in fatigue.



Speed control

The unit is operated using a fail-safe deadman's switch to control ascent speed, up to 15 m/min (49.2 ft/min).



Durability

Stainless steel load-carrying gears and pins provide strength and durability. Sealed gearbox and high-load roller bearings reduce friction under load. Roller bearings are corrosion resistant and do not require lubrication.



Brake

The braking system controls descent and provides workers protection against free falls. The encapsulating jaw cover protects fingers and clothing from catching in the winch.



CE Certified

The Harken Industrial™ PowerSeat® is CE certified to the Machinery Directive and independently verified by Bureau Veritas.



Ergonomic design

The PowerSeat is designed to stay in an upright position, conserving worker energy.

APPLICATIONS

Simple to use and ideal for moving heavy loads

The PowerSeat ascender is ideal for a wide range of applications including wind turbines, building exteriors, search and rescue scenarios — not only as a powered ascender but also as a portable winch or hauler.

- Rope access
- Rescue operations
- Construction
- Renewable energy
- Telecommunications
- Facilities management
- Architectural
- Vessel maintenance
- Utilities, oil & gas
- Theatrical

FAST FACTS

The PowerSeat is a mechanical ascender and hauler

The Powerseat is certified to be used as a powered ascender for access and for hauling and pulling. For example, it can be used for high angle rescue (when attached to an appropriate anchor), or in conjunction with a tripod for confined space/winch operations.

The PowerSeat can be used for single or tandem rescue

The PowerSeat is ideal for one person but can also be used in tandem rescue situations to a maximum working load of 273 kg (600 lb) for gas, 300 kg (660 lb) for battery.

The PowerSeat won't overload even when the working load is exceeded

If the PowerSeat working load is exceeded, the gas engine is designed to stop. Similarly, the electric PowerSeat has a cutoff to stop power to the winch. In either case, the seat is designed to descend safely to the ground where the load can be reduced and operation restarted.

FAQS

Q. What type of fuel does the gas PowerSeat use?

A. The gas PowerSeat runs on unleaded gasoline with a pump octane rating of 86 or higher.

Q: How long does the fuel last in the gas PowerSeat?

A: A full tank of fuel (0.6 L) allows approximately 600 m (1968') climb distance at 273 kg (600 lb).

Q: What is the ascent speed?

A: For the gas version, the rate of climb is 15 m per minute at 120 kg (42.2' per minute at 265 lb). 11 m (36.1') per minute at 273 kg (600 lb).

Q: What training is required? Can anyone use the PowerSeat?

A: Use of the PowerSeat must meet the regulations of the nation and industry in which it is used. It is restricted to those certified for temporary work at height with access and positioning systems using ropes.

Q. What battery does the PowerSeat battery have and how long does the charge last?

A. The PowerSeat battery has a 50.4V lithium-ion battery with a BMS (Battery Management System) to preserve its useful life. Certified IP54. In optimum conditions this has a battery life of 550 m (1804.5') with a 125 kg (276 lb) load.



This is not PPE equipment. Use in conjunction with a full fall-arrest system at all times.

WARNINGS AND INSTRUCTIONS. The user must follow the manufacturer's instructions for each component of the system, which must be provided to the user. The user must read and understand these instructions before using this equipment. Manufacturer's instructions must be followed for proper use and maintenance. Alterations or misuse of this equipment, or failure to follow these instructions, may result in serious injury or death.

Models



PWR-S-G

Gasoline

Fuel efficient; 4-stroke mix of unleaded gasoline.



PWR-S-B

Battery

50.4V lithium-ion battery with BMS battery management; certified to IP54.



© Martin Berner

Part No.	Description	Ascent speed				Weight		Rope Ø			Safe max rated load			
		@ 265 lb/ 120 kg load		@ 600 lb/ 273 kg load		lb	kg	Min	Max	lb	kN			
		ft/min	m/min	ft/min	m/min			in	mm	in	mm			
PWR-S-G	Gas	0-49	0-15	0-36	0-11	32	14.5	3/8	10	1/2	12.7	600	2.7	273
PWR-S-B	Battery	44.3	13.5			35.4	10.8	3/8	10	1/2	12.7	660	3	300

*Plus 3.6 kg (7.9 lb) for battery



This is not PPE equipment. Use in conjunction with a full fall-arrest system at all times.

WARNINGS AND INSTRUCTIONS. The user must follow the manufacturer's instructions for each component of the system, which must be provided to the user. The user must read and understand these instructions before using this equipment. Manufacturer's instructions must be followed for proper use and maintenance. Alterations or misuse of this equipment, or failure to follow these instructions, may result in serious injury or death.

INSPECTION



RESCUE



MANUAL & POWERED WINCHES



Harken Industrial winches are designed to withstand tough conditions to make jobs easier. Applications include: recovery, load lifting, personnel-hoisting and more.



“ **THE LIGHTWEIGHT RIGGING WINCH 500 WAS ABSOLUTELY INVALUABLE;** it’s a superb piece of equipment and we really couldn’t have done the abseil part of our journey without it. It was essential that we could carry it with ease through

the humid temperatures in the jungle. The versatility of the winch, with its ability to lower and raise easily, made it the perfect option for us.

— Dave Ibbertson, Survival & Safety Consultant, Remote Trauma, a UK-based company specializing in safety management in isolated locations, describing operations in the Amazon rainforest

”



LOKHEAD™ WINCH KITS

Remove the risk of accidental release

Self-tailing winch kits are perfect for load hauling and rescue operations



The LokHead™ is a proven high-load, low-friction winch that is a perfect choice anywhere a load needs to be lifted or lowered. Rigged to a tripod, it can be used for confined-space rescue operations, for load moving/hauling, and personnel hoisting. Its lightweight design and use of an unlimited length of fiber rope make this self-tailing winch an ideal choice whether used permanently mounted or portable. The ergonomic design reduces fatigue and optimizes operator strength,

while safety features such as locking jaws offer complete protection against free fall or accidental release. The LokHead winch is available in two different certified kits: The Fire/Rescue kit, which meets the NFPA Standard on Life Safety Rope and Equipment for Emergency Services (NFPA 1983), and the standard kit, which is compliant with EN1496 for Human Suspension and certified under EN13157 Machinery Directive for lifting goods and equipment.



Lightweight
The LokHead winch and mounting bracket can be incorporated into a rescue/lifting system without significantly increasing overall weight.



Reliable
The braking system controls descent and provides workers protection against free-falls. The encapsulating jaw cover protects fingers and clothing from catching in the winch.

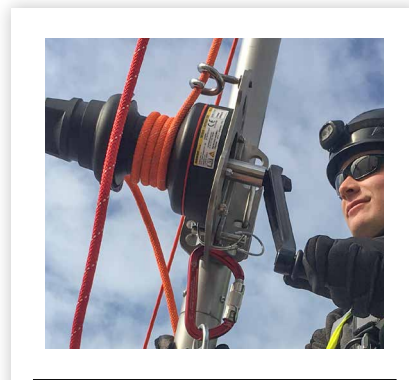

Ergonomic
Easy to rig and efficient, the LokHead makes the most of the operator's efforts. The winch offers two gears; 13.5:1 for low load/high speed use and 39.90:1 for higher load applications.



CE Certified

Standard Kit is compliant with EN1496 for Human Suspension and certified under EN13157 Machinery Directive for lifting goods and equipment.

Fire/Rescue Kit meets the NFPA Standard on Life Safety Rope and Equipment for Emergency Services NFPA 1983 (2017 ED) "T".



Versatile

The winch is designed for use with fiber rope 10–12.7 mm (3/8–1/2") in diameter and unlimited rope length.



Drive flexibility

The winch can be driven manually with the provided B10AL handle. Alternatively, use a compatible power drill with the available power tool adapter (for lifting goods or equipment only) to drive the winch. Not EN13157 compliant.

FAST FACTS

The LokHead winch allows unlimited rope length

The LokHead winch is able to pull an infinite length of rope. The end of the rope does not dead-end on the drum.

The LokHead winch kits are certified

The standard kit is certified under EN13157 Machinery Directive for lifting goods and equipment, CE compliant with EN1496 for Human Suspension and the Fire/Rescue kit meets the NFPA Standard on Life Safety Rope and Equipment for Emergency Services (NFPA 1983).

The LokHead winch mounts to various structures

The LokHead winch can be mounted to the Harken Industrial TelluMount (see page 22) and appropriately rated tripods using compatible mounting brackets.

APPLICATIONS & MAINTENANCE

Simple to use and ideal for diverse applications

The LokHead winch can be used anywhere a load needs to be lifted or lowered. Rigged to a tripod, it can be used in confined space rescue operations, for load moving/hauling, and personnel hoisting.

Care is easy

Can be flushed clean with fresh water.

Annual maintenance

Contact a Harken Industrial Certified Service Center for product maintenance and repair.





INLH500KIT.US



INLH500KIT

FIRE/RESCUE KIT INCLUDES

(Meets NFPA certification Requirements)

- LokHead winch with reversible plate
- Winch handle
- Tripod adapter with counter plate
- Control lever
- CMC Variable Anchor strap
- 2 CMC ProSeries® carabiners
- Waterproof case

OPTIONAL

Power tool adapter — protect-connect

This special tool helps preserve the LokHead winch when it is used for long duty cycles or when the winch is under intense loads. Not EN13157 compliant.



INHDTOOL

TelluMount

When used in combination with the LokHead winch kit the TelluMount provides a myriad of rigging solutions, either on the ground or other flat surface, or mounted to a wall. The TelluMount is made of durable aluminum and features holes in a variety of sizes enabling it to be mounted in many ways. It's a perfect tool for confined space operations and other rope access operations.



INTMOUNT

STANDARD KIT INCLUDES

(CE certified)

- LokHead winch with reversible plate
- Winch handle
- Universal tripod adapter
- Control lever
- Anchor strap with connectors
- 2 carabiners
- Waterproof case

Power tool adapter

Fits all standard chucks. Used for lifting goods or equipment only, not for human suspension. Not EN13157 compliant.



7431

Winch handle

A shorter handle that provides greater speed, but less power.



B8AL

Part No.	Description	Rope Ø				Weight				Maximum working load (goods/equipment)			Maximum working load (human suspension)		
		Min in	Min mm	Max in	Max mm	Kit lb	Kit kg	Winch/plate only lb	Winch/plate only kg	lb	kN	kg	lb	kN	kg
INLH500KIT	LokHead winch standard kit (CE certified)	3/8	10	1/2	12.7	30	13.6	12.3	5.6	1102	4.9	500	529	2.4	240
INLH500KIT.US	LokHead winch fire/rescue kit (Meets NFPA certification requirements)	3/8	10	1/2	12.7	32	14.5	14.2	6.4	1102	4.9	500	485	2.2	220



Maximum working load for lifting & pulling load applications: 500 kg/1102 lb;
Maximum working load for human suspension: INLH500KIT:240 kg/529 lb, NLH500KIT.US: 220 kg/485 lb

WARNINGS AND INSTRUCTIONS. You must carefully read, understand, and follow all of the warnings and instructions in the manual provided by Harken Industrial in order to avoid an accident. Never, under any circumstances, exceed the maximum working load.

In accordance with Directive 2009/104/EC persons may be lifted only by means of work equipment and accessories provided for that purpose. Without prejudice to Article 5 of Directive 89/391/EC, exceptionally, work equipment which is not specifically designed for the purpose of lifting persons may be used for that purpose, provided appropriate action has been taken to ensure safety in accordance with national legislation and/or practice providing for appropriate supervision.





LOKHEAD™ POWER HAULER (POWERSEAT-COMPACT)

Available in gas, electric and battery versions

Portable power for hauling and ascending



Harken Industrial™ Lokhead™ Power Haulers are lightweight portable winches that are used in powered hauling applications and as mechanical ascenders for working at height. When used as an ascender, the user is suspended under the unit with full control from below. Available in gasoline

and battery versions. The gasoline version of the Power Hauler can be operated with ease and confidence in situations where engine emissions are not restricted. The battery Power Hauler can be operated in both outdoor and indoor environments where engine emissions are restricted.



Speed control
The unit is operated using a fail-safe deadman's switch to control ascent speed, up to 15 m/min (49.2 ft/min).



Durability
Stainless steel load-carrying gears and pins provide strength and durability. Sealed gearbox and high-load roller bearings reduce friction under load. Roller bearings are corrosion resistant and do not require lubrication.



Brake
The braking system controls descent and provides workers protection against free falls. The encapsulating jaw cover protects fingers and clothing from catching in the winch.



CE Certified

The Harken Industrial™ Power Hauler (PWRS-G.COMPACT, PWRS-E.COMPACT, PWRS-B.COMPACT) is CE certified under the 2006/42/EC Machinery Directive and independently verified by Bureau Veritas.



Automatic Cut-out

Power Hauler is tuned to stall when the working load is exceeded.

FAST FACTS

The Power Hauler winch allows unlimited rope length

The Power Hauler winch is able to pull an infinite length of rope. The end of the rope does not dead-end on the drum.

All Power Haulers are CE certified

Harken Industrial Power Haulers (PWRS-G.COMPACT, PWRS-B.COMPACT) are CE certified to the Machinery Directive and independently verified by Bureau Veritas. Power Haulers can be rigged to assist with hauling and pulling and used as powered ascenders for access.

Power Haulers can be used for single or tandem rescue

Power Haulers are ideal for single-person use, but can be used in tandem rescue operations to a maximum working load of 273 kg (600 lb) for gas and 300 kg (660 lb) for battery versions.

FAQS

Q: What type of fuel does the gas Power Hauler use?

A: The gas Power Hauler runs on unleaded gasoline with a pump octane of 86 or higher.

Q: How long does the fuel last in the gas Power Hauler?

A: A full tank of fuel (0.6 L) allows approximately 600 m (1968') climb distance with a load of 273 kg (600 lb).

Q. What are the specifications for the Power Hauler battery, and how long does the charge last?

A. The Power Hauler has a 50.4V lithium-ion battery with a BMS (Battery Management System) to preserve its useful life. Certified IP54. In optimum conditions this battery has a life of 550 m (1804.5') with a 125 kg load (275.6 lb).

PWRS-G.COMPACT



PWRS-B.COMPACT



Part No.	Description	Ascent speed				Weight		Rope Ø				Safe working load		
		@ 265 lb/ 120 kg load		@ 600 lb/ 273 kg load		lb	kg	Min	Max		lb	kg		
		ft/min	m/min	ft/min	m/min	ft/min	m/min	in	mm	in	mm	lb	kN	kg
PWRS-G.COMPACT	Compact gas	0-49	0-15	0-36	0-11	29.8	13.5	3/8	10	1/2	12.7	600	2.7	273
PWRS-B.COMPACT	Compact battery	44.3	13.5			35.4	10.8	3/8	10	1/2	12.7	660	3	300

*Plus 3.6 kg (7.9 lb) for battery



This is not PPE equipment.
Use in conjunction with a full fall-arrest system at all times.

WARNINGS AND INSTRUCTIONS. The user must follow the manufacturer's instructions for each component of the system, which must be provided to the user. The user must read and understand these instructions before using this equipment. Manufacturer's instructions must be followed for proper use and maintenance. Alterations or misuse of this equipment, or failure to follow these instructions, may result in serious injury or death.



RIGGING WINCH

A universal & adaptable lifting solution

A lightweight, CE certified, portable winch

The Rigging Winch provides the user with a lightweight, CE certified, portable winch mounted to a robust adapter plate. The 2-speed 500 model weighs just 7 kg (15.4 lb). Its maximum working load of 4.9 kN (1102 lb) maximizes operator pulling power by up to 40 times. Multiple mounting options provide versatility when working in challenging or remote environments.



Design

The mounting plate is sculpted to remove excess weight and provides multiple attachment points without compromising strength. The pigtail lead ensures correct alignment and loading of the winch for maximum efficiency.



Fiber rope

The winch is designed for use with fiber rope up to 12 mm (1/2") in diameter, reducing weight and allowing alignment to the load. Smooth surfaces and chafe-free design reduces rope wear. The unique drum design maximizes grip on the rope.



Winch

Winches feature 17-4 PH stainless steel load-carrying gears and pins for strength and durability. Packages include a universal mounting plate, 10" winch handle, and the two-speed Rigging Winch 500.



CE Certified

CE certified under EN13157 (Machinery Directive) with a maximum working load of 500 kg (1102 lb) for Rigging Winch 500.

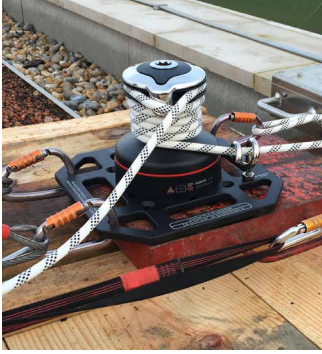

Options

For use with multiple attachments, depending on the environment and industry: ratchet straps, M10 bolts, carabiners, and scaffold clamps.

FAST FACTS

Rigging Winches allow unlimited rope length

Rigging winches are able to pull an infinite length of rope. The end of the rope does not dead-end on the drum.

The Rigging Winch can be used for human suspension for rescue

In accordance with Directive 2009/104/EC persons may be lifted only by means of work equipment and accessories provided for that purpose. Without prejudice to Article 5 of Directive 89/391/EC, exceptionally, work equipment which is not specifically designed for the purpose of lifting persons may be used for that purpose, provided appropriate action has been taken to ensure safety in accordance with national legislation and/or practice providing for appropriate supervision.

The Rigging Winch kit is adaptable for customized applications

Because attachments and fittings are used differently depending on operational purpose, they are not included with the kit. This allows for more of a customized application of the kit. Harken Industrial can provide advice on the best attachment solution.

APPLICATIONS

Simple to use and ideal for diverse applications

- Access and rescue
- Confined space
- Wind turbine transition piece davits
- Commercial marine
- Telecoms
- Construction
- Utility masts
- Stage and theatre rigging



INRW500
Rigging Winch 500

Part No.	Description	Rope Ø				Weight		Maximum working load		
		Min in	Min mm	Max in	Max mm	lb	kg	lb	kN	kg
INRW500*	Rigging Winch 500	5/16	8	1/2	12	15.4	7	1102	4.9	500

* Kit includes: Rigging winch, handle, mounting plate, and pigtail.



Maximum working load for lifting & pulling load applications: 500 kg (1102 lb) for Rigging winch 500.

WARNINGS AND INSTRUCTIONS. You must carefully read, understand, and follow all of the warnings and instructions in the manual provided by Harken in order to avoid an accident. Never, under any circumstances, exceed the maximum working load.



HIGH CAPACITY DRUM RIGGING WINCHES

Extra tall drum for 5 wraps of rope

A lightweight, CE certified, portable winch



The 500 and 750 High Capacity Drum Rigging Winches feature an extra tall drum to accommodate 5 wraps of rope, for use by arborists and other industries where extra lifting or lowering capacity is required. More wraps mean increased rope to capstan contact area, which leads to high efficiency when pulling. Rigging winches allow a single ground person to lift, lower, and lock off tremendous loads

quickly and safely, without tying knots. Both models have two settings: one for more power and one for increased speed. The 500 model provides a 13.50:1 and a 39.90:1 mechanical advantage for ropes up to 12 mm (1/2"). The 750 model provides a 44:1 and a 22:1 mechanical advantage for ropes up to 22 mm (7/8").



Powerful

The High Capacity Drum Rigging Winch 500 has a max working load of 500 kg (1102 lb) and the 750 model has a max working load of 750 kg (1653 lb).



Fiber rope

The winch is designed for use with fiber rope up to 12 mm (1/2") in the 500 model and 22 mm (7/8") in diameter in the 750 model. Smooth surfaces and chafe-free design reduces rope wear. The unique drum design maximizes grip on the rope.

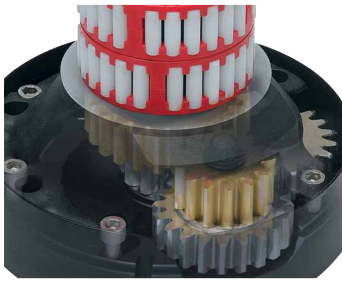

Durability

Stainless steel load-carrying gears and pins provide strength and durability. High-load roller bearings reduce friction under load. The roller bearings are corrosion resistant and do not require lubrication.

FAST FACTS

The High Capacity Rigging Winches are both in-stock and built to order

The High Capacity Drum Rigging Winch 750 is an in-stock item and the High Capacity Drum Rigging Winch 500 is built to order (with a 3-week lead time).

Multiple drum materials available

The High Capacity Drum Rigging Winch 500 and 750 both come with aluminum or chrome drums, with other finishes available upon request. Please contact Harken Industrial – Italy at +39 (0)31 3523511 for details.

The High Capacity Drum Rigging Winches allow unlimited rope length

The High Capacity Drum Rigging winches are able to pull an infinite length of rope. The end of the rope does not dead-end on the drum.

High Capacity Drum Rigging Winch kits are adaptable for customized applications

Because attachments and fittings are used differently depending on operational purpose, they are not included with the kit. This allows for more of a customized application of the kit. Harken Industrial can provide advice on the best attachment solution.

Regular service maintenance keeps High Capacity Drum Rigging Winches working properly

Service and winch maintenance must be in accordance with user instruction manual of the final assembled system.



46.2STGNA



46.2STGNC



40.2STGNA



40.2STGNC

Part No.	Description	Rope Ø				Weight		Maximum working load*	
		Min in	Min mm	Max in	Max mm	lb	kg	lb	kg
40.2STGNA	Aluminum High Capacity Drum Rigging Winch 500	5/16	8	1/2	12	11.7	5.3	1102	500
40.2STGNC	Chrome High Capacity Drum Rigging Winch 500	5/16	8	1/2	12			1102	500
46.2STGNA	Aluminum High Capacity Drum Rigging Winch 750	3/8	10	7/8	22			1653	750
46.2STGNC	Chrome High Capacity Drum Rigging Winch 750	3/8	10	7/8	22	20.1	9.12	1653	750

*Per CE certified 2006/42/EC Machinery Directory Standards.



Maximum working load for lifting & pulling load applications: 500 kg (1102 lb) for High Capacity Drum Rigging winch 500 and 750 kg (1653 lb) for Rigging winch 750.

WARNINGS AND INSTRUCTIONS. You must carefully read, understand, and follow all of the warnings and instructions in the manual provided by Harken Industrial in order to avoid an accident. Never, under any circumstances, exceed the maximum rated load.

RAILS & TROLLEYS

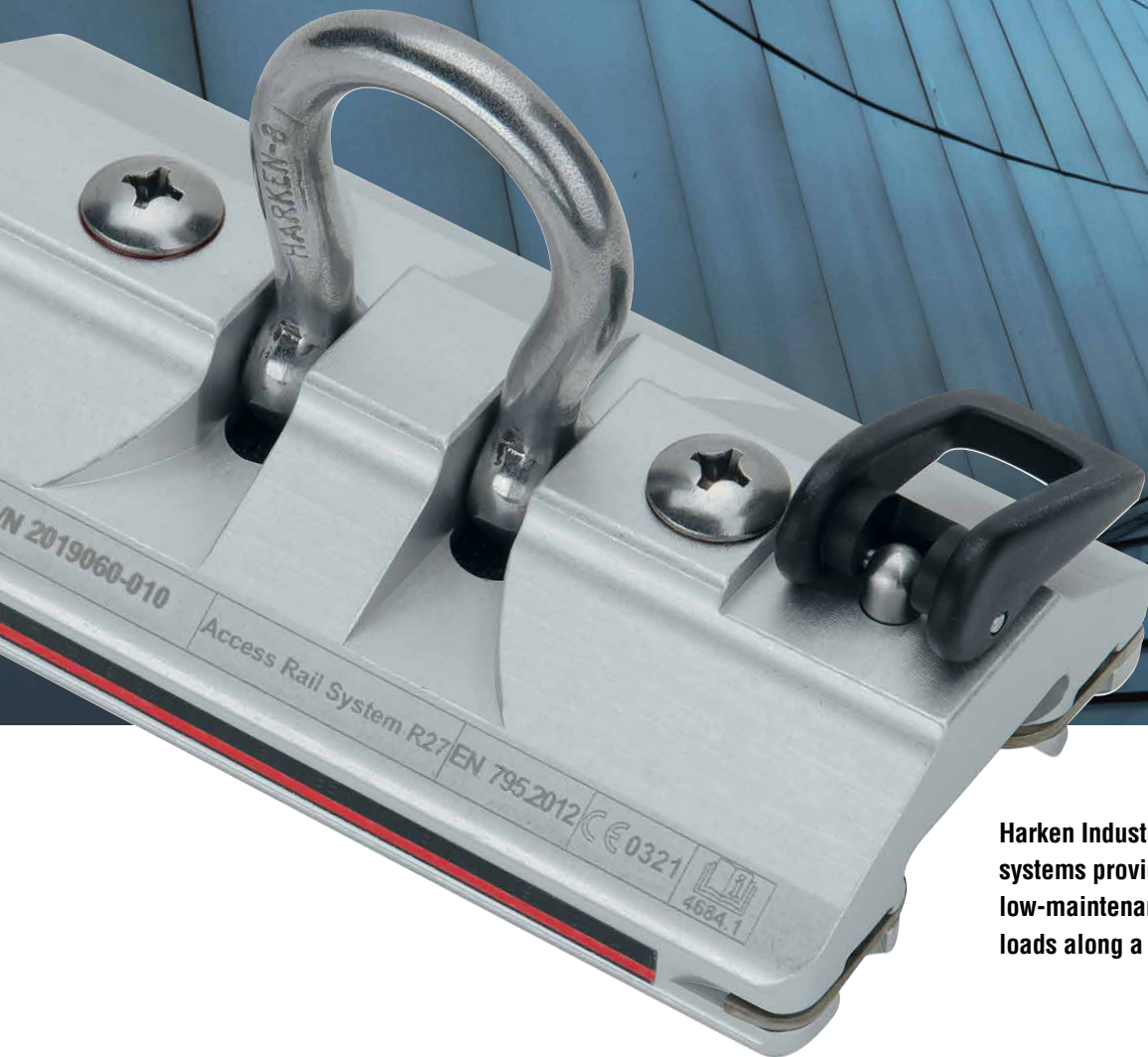

Harken Industrial™ rail and trolley systems provide low-friction, low-maintenance ways to move loads along a fixed path.

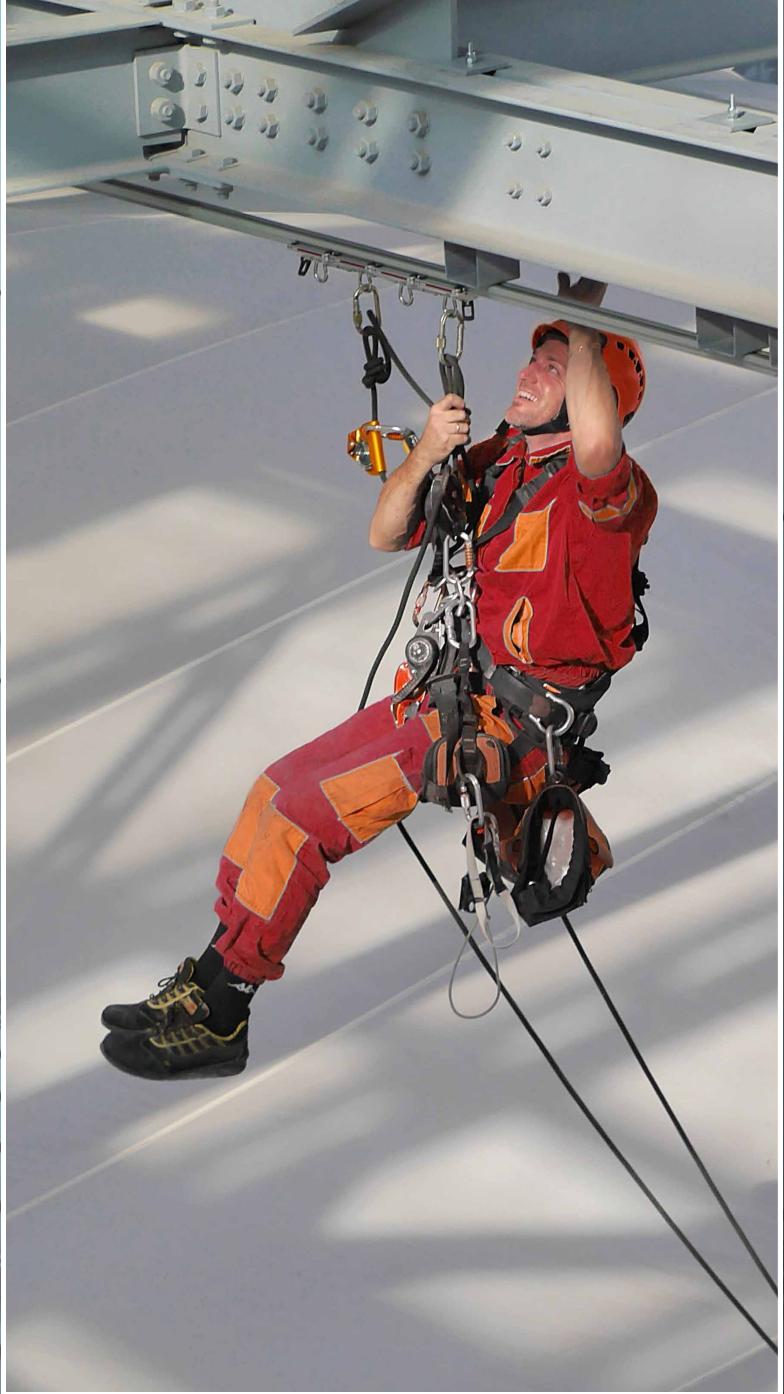

“ While working on the Generali Tower in Milan, we requested that a rope-access and fall-arrest system be incorporated into the building design that allowed both internal and external access for maintenance.

HARKEN INDUSTRIAL’S R27 LONG SPAN ACCESS RAIL SYSTEM DELIVERED THE EASE OF ACCESS REQUIRED WHILE BEING “INVISIBLE” AGAINST THE BUILDING’S SLEEK GLASS FAÇADE.

— Sicurlive Group, Milan Italy

Sicurlive Group develops, produces and supplies certified fall-arrest devices. They also install safety systems and provide technical training.



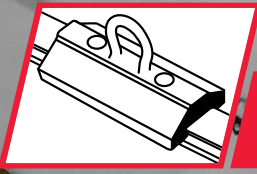

ACCESS RAIL

Improving safety while working at height

Work at height with freedom of movement

Access Rail is designed for use as an adjustable anchorage point for rope access and fall arrest. It provides the operator freedom of vertical and horizontal movement at height and also the ability to lock into position while working.

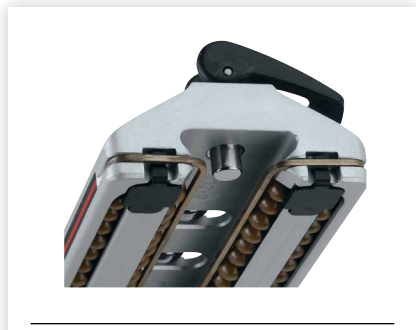

Design

Lightweight trolleys are constructed of strong, one-piece solid aluminum. The adjustable pinstop allows trolleys to be moved along the rail and locked into a new location.

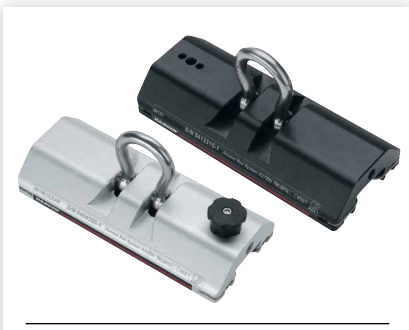

Durability

Trolleys and rails are available in black hardcoat or clear-anodized finishes for maximum corrosion protection.



Low maintenance ball bearings

Torlon® ball bearings handle high loads, reducing friction so the trolley moves smoothly along the rail. Retaining clips keep ball bearings captive when the trolleys are removed for maintenance.

CE Certified



The Harken Industrial™ 27 mm Access Rail system can be used for suspension and fall arrest. The rails are tested by Notified Body, CE compliant under EN795.2012 Type D and CEN/TS 16415:2013. The trolleys are tested by Notified Body, CE certified under EN795.2012 Type B.



Style

The Access Rail system can be mounted in 3 horizontal planes. A wheel toggle attachment can be used for discrete over-edge parapet and inclined surface installations.

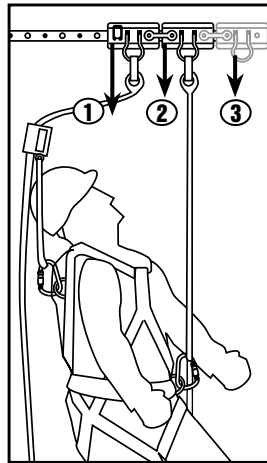

⚠ WARNING! Avoid personal injury. The Access Rail System must be used with a full body safety harness and/or working harness or chair that meets CE/ANSI EN813 and OSHA support standards.

① Backup trolley

Use a full-body safety harness attached by lanyard or rope to access trolley with *pinstop*. Full-body safety harness must meet CE/ANSI and OSHA support standards.

② Main trolley

Use a working harness or chair attached by lanyard or rope to access trolley. Working harness or chair must meet CE/ANSI and OSHA support standards.

③ Tool service trolley

Add an optional trolley and coupler to work as your tool service carrier.

FAST FACTS

Harken Industrial Access Rail is CE certified

The trolleys are tested by Notified Body and CE certified under EN795.2012 Type B, meet ANSI Z359, and are OSHA compliant. The rails are tested by Notified Body and are EN795.2012 Type D compliant, meet ANSI Z359, and are OSHA compliant.

Skills learned while working with other rail systems are transferable

The training required to work with Harken Industrial Access Rail is limited. Only a short training session to become familiar with this system is required to ensure safe installation. Harken Industrial offers an approved installer training course. Contact your local Harken Industrial office for more information.

The Access Rail system can be fitted retroactively

The simplicity of the system means Harken Industrial Access Rail can be installed on existing buildings.

The Access Rail system is durable and provides smooth movement and precise positioning

The construction and materials used in the Harken Industrial Access Rail have created a stronger system compared to others, with smoother linear motion and precise positioning capabilities. The Access Rail is made of anodized, one-piece aluminum components, ensuring corrosion resistance, low maintenance, and a long working life.

Access Rail systems by application

Harken Industrial manufactures several rail systems for industrial, architectural and commercial marine applications. The following matrix offers a quick method of selecting a rail type based on the work-at-height application.

Industrial rail type	Fall restraint	Fall arrest	Rope access/suspension	Work positioning	Certifications		Static strength* (kN)	Max span between brackets
					EN 795:2012	CEN/TS 16415:2013		
R27	✓	✓	✓	✓	✓	✓	13	0.2–0.3 depending on configuration
R27LS	✓	✓	✓	✓	✓	✓	22	3 m
R32	✓	✓	✓	✓	✓	✓	22	0.3 m
TR31	✓	✓					12	1.3 m

*Static strength obtained by independent test.

R27 Components

SIMPLE TO USE AND IDEAL FOR DIVERSE APPLICATIONS

The 27 mm and 32 mm Access Rail systems have a wide range of applications and can be used in a variety of industries:

- Construction/steel frame and envelope projects
- Renewable energy/blade cleaning
- Facilities management/asset integrity inspections
- Fall arrest/rope access (when two trolleys are used)
- Architectural/building survey
- Vessel maintenance
- Stage management, filming and rigging

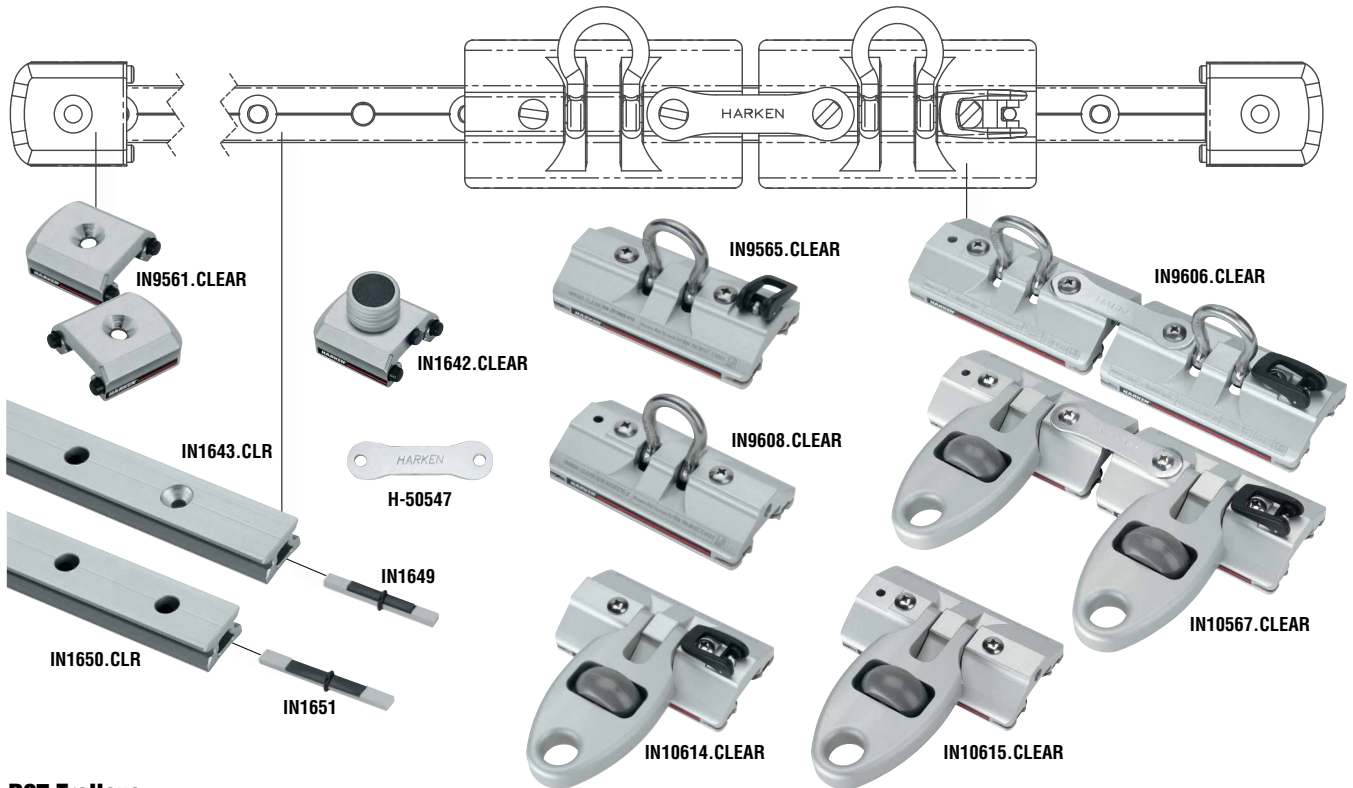

R27 Trolleys

Part No.	Description	Length		Width		Fits rail
		in	mm	in	mm	
IN9606.CLEAR*	2-trolley	10 3/4	273	2 3/4	70	IN1643, IN1650, INR27.LS
IN10567.CLEAR*	2-trolley with wheel toggle	10 3/4	273	5 15/16	150	IN1643, IN1650
IN9565.CLEAR*	Trolley with pinstop	5 3/16	132	2 3/4	70	IN1643, IN1650, INR27.LS
IN9608.CLEAR*	Trolley	5 3/16	132	2 3/4	70	IN1643, IN1650, INR27.LS
IN10614.CLEAR*	Trolley with wheel toggle & pinstop	5 3/16	132	5 15/16	150	IN1643, IN1650
IN10615.CLEAR*	Trolley with wheel toggle	5 3/16	132	5 15/16	150	IN1643, IN1650

*To order black hardcoat-anodized, remove .CLEAR from end of part number.

R27 Rail & Accessories

Part No.	Description	Length		Mounting hole spacing		Fasteners		Endstop	Splice link/rail	
		ft/in	m	in	mm	in	mm			
IN1643.3M.CLR*	HL rail pinstop, clear	9' 10 1/16"	3	3 15/16	100	5/16 FH	8 FH	IN1642.CLEAR*, IN9561.CLEAR*	IN1649/—	
IN1643.3.6M.CLR*	HL rail pinstop, clear	11' 9 3/4"	3.6	3 15/16	100	5/16 FH	8 FH	IN1642.CLEAR*, IN9561.CLEAR*	IN1649/—	
IN1650.3M.CLR*	Rail for SHCS fasteners, clear	9' 10 1/16"	3	3 15/16	100	5/16 SHCS	8 SHCS	IN1642.CLEAR*, IN9561.CLEAR*	IN1651/—	
IN1650.3.6M.CLR*	Rail for SHCS fasteners, clear	11' 9 3/4"	3.6	3 15/16	100	5/16 SHCS	8 SHCS	IN1642.CLEAR*, IN9561.CLEAR*	IN1651/—	
IN10630.CLR*	HL rail for 3.04 m, 80 mm hole space	9' 11 11/16"	3.04	3 5/32	80	5/16	8			
IN1642.CLEAR*	Endstop with adjustable pin (sold individually)	2 5/16"	59 mm			5/16 FH	8 FH		—/IN1643	
IN9561.CLEAR*	Endstops (sold in pairs)	2 1/4"	57 mm						—/IN1650	
IN1649	Splice link			Purchase one splice link for each rail joint						—/IN1643
IN1651	Splice link			Purchase one splice link for each rail joint						—/IN1650
H-50547	Coupler plate			Purchase to connect tool trolley to access trolley						

Use only endstops listed above. *To order black hardcoat-anodized, remove .CLEAR or .CLR from end of part number.

R32 Components

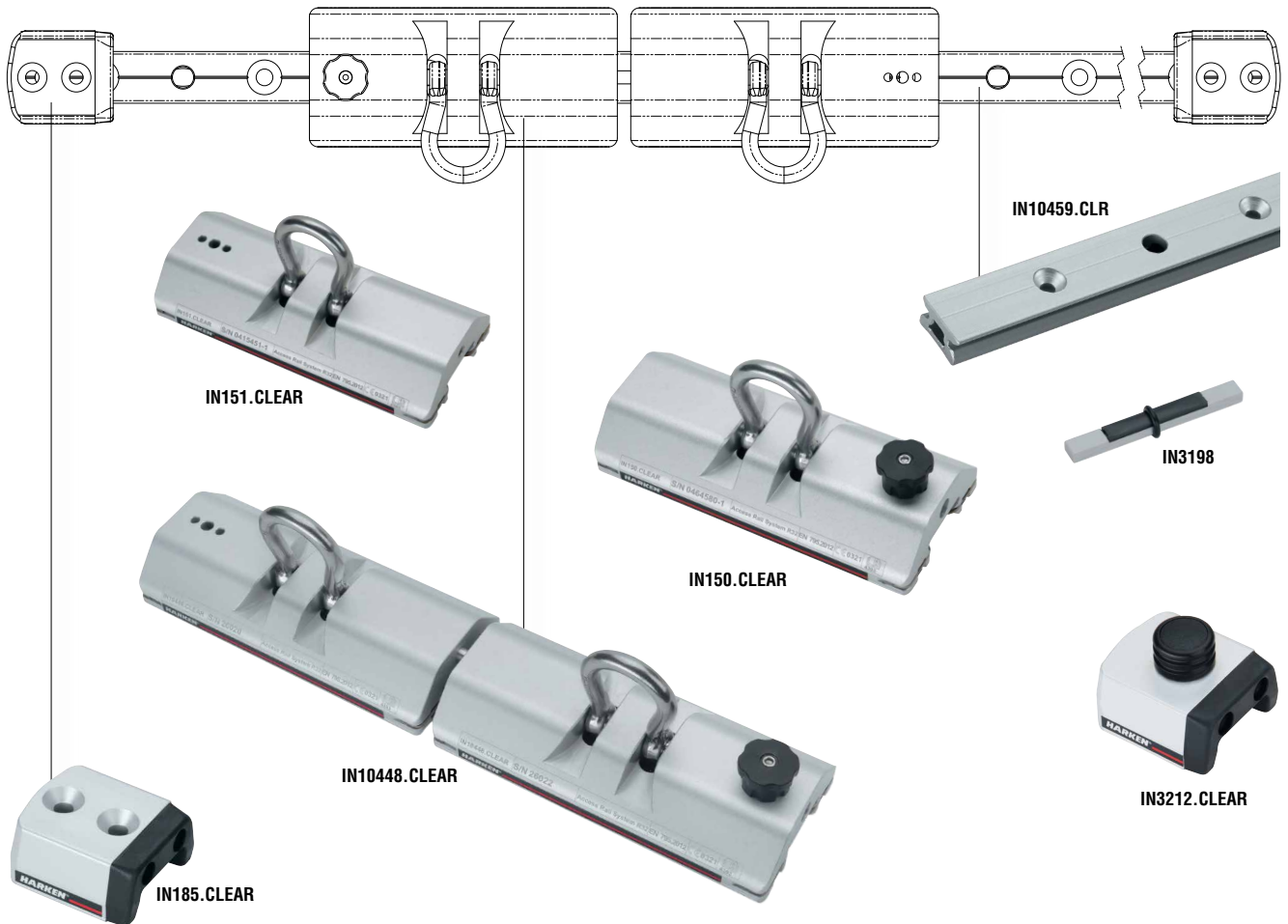

R32 Trolleys

Part No.	Description	Length		Width		Fits rail
		in	mm	in	mm	
IN150.CLEAR*	Single trolley with pinstop	7 3/8	192	3 11/32	85	IN10459.CLR
IN151.CLEAR*	Single trolley	7 3/8	192	3 11/32	85	IN10459.CLR
IN10448.CLEAR*	2-trolley assembly/coupler	15 3/16	385	3 11/32	85	IN10459.CLR

*To order black hardcoat-anodized, remove .CLEAR from end of part number.

R32 Rail & Accessories

Part No.	Description	Length		Mounting hole spacing		Fasteners		Endstop	Splice link
		ft/in	m	in	mm	in	mm		
IN10459.CLR*	Pinpoint rail for countersunk fasteners	9' 10 1/16"	3	3 15/16	100	3/8 SHCS	10 SHCS	IN3212, IN185	IN3198
IN3198	Splice link	3'	76 mm	Purchase one splice link for each rail joint.					IN10459
IN3212.CLEAR	Removable endstop	2 9/16"	65 mm	Purchase one endstop for each end of system rail.					
IN185.CLEAR*	32 mm rail endstop	2 9/16"	65 mm	Purchase one endstop for each end of system rail.					

Use only endstops listed above. *To order black hardcoat-anodized, remove .CLEAR or .CLR from end of part number.

HARKEN INDUSTRIAL EXCEPTION: The Access Rail system may be used for human suspension and fall arrest.



WARNINGS AND INSTRUCTIONS. You must carefully read, understand, and follow all of the warnings and instructions in the manual provided by Harken Industrial™ in order to avoid an accident. Never, under any circumstances, exceed the maximum number of people working simultaneously on a span.



LONG-SPAN ACCESS RAIL

Long-span version of classic R27 rail system developed

Long-Span Access Rail (R27LS) was developed as an alternative to its flagship R27 Classic Access Rail system. R27LS has a more robust profile than the classic system, allowing it to handle longer spans without compromising strength. Support brackets are offered in a variety of styles for ease of installation, and for mounting on surfaces of different types and configurations. Engineered for diverse applications, R27LS is used as a horizontal rail system in many fields (industrial, architectural,

civil, etc.) to create a rigid mobile anchor for fall protection and rope access systems. The longer span between brackets reduces installation costs: 3 m (9.84') span for fall protection; as much as 1.5 m (4.90') for human suspension.

Available standard in clear-anodized. A wide range of optional specialty colors are available via request/special order. Ask your Harken Industrial™ rep for details.



Proven trolley assembly

Long-Span Access Rail uses the proven R27 ball bearing trolley assembly for freedom of movement under load.



Low-profile aluminum and stainless steel brackets

Low-profile, corrosion-resistant brackets of extruded T6082 anodized-aluminum or sandblasted stainless steel mount on a variety of surfaces.

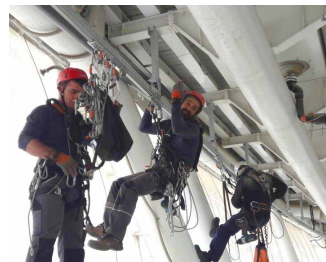

Multiple users

R27LS is certified to support as many as four users on a single span for fall protection and two users for human suspension.



CE Certified

The Harken Industrial™ 27 mm Long-Span Access Rail system can be used for human suspension and fall arrest. The rails are tested by Notified Body, CE compliant under EN795.2012 Type D and CEN/TS 16415:2013. The trolleys are tested by Notified Body, CE certified under EN795.2012 Type B.

(Product images not to scale)

INMID-ENTRY1.LS

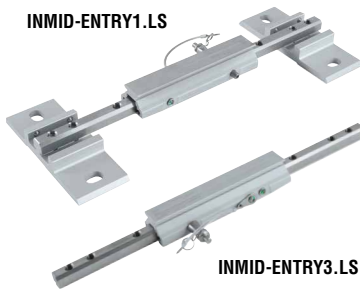

INMID-ENTRY3.LS

Mid-entry connectors

The track can be opened to insert or remove trolleys at any point along the line without removing the endstop using slugs rather than fasteners for easy installation. Two types of mid-entry connectors are available for aluminum and steel brackets for all single car models.



INSTOP-OPEN.LS

Endstop

The small and compact endstop design is openable with a double safety system. If desired, trolleys can be inserted or removed at the ends of a line easily with the insertion or removal of a single pin.



IN9606.CLEAR

IN158.CLEAR

IN9608.CLEAR

IN1642.CLEAR

IN9565.CLEAR

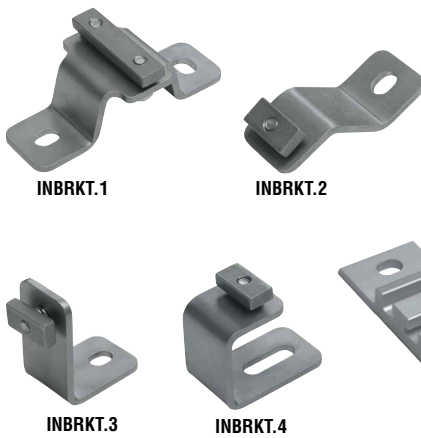

INBRKT.1

INBRKT.2

INBRKT.3

INBRKT.4

INBRKT.AL



INLINK.AL

INR27.LS

INLINK.LS

INSTOP.LS

INPIN.LS

Trolleys

Part No.	Description	Length		Width		Fits rail
		in	mm	in	mm	
IN158.CLEAR*	2-trolley without pinstop**	10 3/4	273	2 3/4	70	IN1643, IN1650, INR27.LS
IN9606.CLEAR*	2-trolley**	10 3/4	273	2 3/4	70	IN1643, IN1650, INR27.LS
IN9608.CLEAR*	Trolley	5 3/16	132	2 3/4	70	IN1643, IN1650, INR27.LS
IN9565.CLEAR*	Trolley with pinstop	5 3/16	132	2 3/4	70	IN1643, IN1650, INR27.LS

*To order black hardcoat-anodized, remove .CLEAR from end of part number. **IN158 and IN9606 trolleys do not work with turntables or mid-entry connectors.

Rail

Part No.	Description	Material	Length		Weight kg/m
			ft/in	m	
INR27.LS	Long-span rail, clear*	Anodized aluminum	9' 10 1/16"	3	1.7

*Available standard in clear-anodized. A wide range of optional specialty colors are available via request/special order. Ask your Harken Industrial rep for details.

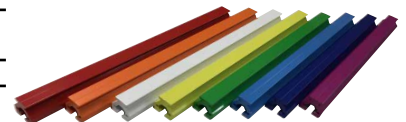

HARKEN INDUSTRIAL EXCEPTION: The Access Rail system may be used for human suspension and fall arrest.



WARNINGS AND INSTRUCTIONS. You must carefully read, understand, and follow all of the warnings and instructions in the manual provided by Harken Industrial in order to avoid an accident. Never, under any circumstances, exceed the maximum number of people working simultaneously on a span.

R27 Long-span Access Rail Mounting Accessories

Part No.	Description	Material	Fasteners		Includes
			in	mm	
INBRKT.1	Bracket "Ω"*	Stainless steel	3/8 - 7/16	M10 - M12	1 bracket, 1 double-hole insert, 2 screws, 2 washers
INBRKT.2	Bracket "S"*	Stainless steel	3/8 - 7/16	M10 - M12	1 bracket, 1 single-hole insert, 1 screw, 1 washer
INBRKT.3	Bracket "L"*	Stainless steel	3/8 - 7/16	M10 - M12	1 bracket, 1 single-hole insert, 1 screw, 1 washer
INBRKT.4	Bracket "C"*	Stainless steel	3/8 - 7/16	M10 - M12	1 bracket, 1 single-hole insert, 1 screw, 1 washer
INLINK.LS	Structural connector	Stainless steel			1 complete connector, 2 INPIN.LS
INBRKT.AL	Low-profile bracket	Anodized aluminum	3/8 - 7/16	M10 - M12	1 bracket, 2 stud screws
INLINK.AL	Low-profile connector	Anodized aluminum	3/8 - 7/16	M10 - M12	1 connector, 10 stud screws, 2 INPIN.LS
INMID-ENTRY1.LS	Opening connector for aluminum brackets	Aluminum/stainless steel	3/8 - 7/16	M10 - M12	1 mid-entry connector for aluminum brackets
INMID-ENTRY3.LS	Opening connector for steel brackets	Aluminum/stainless steel	3/8	M10	1 mid-entry connector for steel brackets
INSTOP.LS	Fixed endstop	Stainless steel			1 endstop, 2 M6 self-threading screws
INSTOP-OPEN.LS	Opening endstop	Stainless steel			1 endstop, 2 M6 self-threading screws
IN1642.CLEAR	Endstop with adjustable pin (sold individually)*				
INPIN.LS	Alignment pin*	Stainless steel			1 pin (order 2 INPIN.LS for each rail section)
H-50547	Coupler plate*				

*Mounting bracket centers: Fall Arrest: 3 meters (10'); Rope Access/Suspension: 1.5 meters (5').

**To mount this endstop, drill and tap a 10 mm hole on the rail.

‡To order black hardcoat-anodized, remove .CLEAR from end of part number.

R27 Long-span Access Rail Turntables

Turntables allow users to easily change trolley directions without disconnecting from the rail system.

INTURN1.LS allows 90° directional changes. INTURN2.LS is designed for 'T' rail layouts and 180° or 90° directional changes. Both options are tested by Notified Body and compliant with EN795:2012 Class D.



Trolley directional change using turntable.



INTURN1.LS

INTURN2.LS

Part No.	Description	Material	Mounting accessories	Includes
INTURN1.LS	Turntable "L"	Aluminum/stainless steel	All R27 LS brackets	4 INPIN.LS
INTURN2.LS	Turntable "T"	Aluminum/stainless steel	All R27 LS brackets	6 INPIN.LS

Double trolleys (IN9606.CLEAR) cannot be used with the turntable. Two single trolleys must be used.

HARKEN INDUSTRIAL™ EXCEPTION: The Access Rail system may be used for human suspension and fall arrest.



WARNINGS AND INSTRUCTIONS. You must carefully read, understand, and follow all of the warnings and instructions in the manual provided by Harken Industrial in order to avoid an accident. Never, under any circumstances, exceed the maximum number of people working simultaneously on a span.



CE Certified

The Harken Industrial™ 27 mm Long-Span Access Rail system can be used for human suspension and fall arrest. The rails are tested by Notified Body, CE compliant under EN795.2012 Type D and CEN/TS 16415:2013. The trolleys are tested by Notified Body, CE certified under EN795.2012 Type B.

R27LS trolleys and accessories for curved rail installations

Harken Industrial™ introduces compact trolleys, accessories and three 90-degree curved rails for tight radius installations up to a 40 cm radius curve for R27LS systems.





INCAR1-CURVE
INCAR2-CURVE

Compact trolleys
The condensed trolleys have a shackle or swivel top offering connection versatility and ultimate safety for fall arrest or rope access with the ability to round tight corners. The trolley's design helps prevent exterior dirt from getting inside the ball bearing system.



Low maintenance ball bearings
Torlon® ball bearings handle high loads, reducing friction so the trolley moves smoothly along the rail. Bearings remain captive when the trolleys are removed for maintenance.



INR27-CURVECONCAVE.LS
INR27-CURVEFLAT.LS
INR27-CURVECONVEX.LS

90-degree curved rails
Three 90-degree curved rail options offer tighter corners with a convex, concave or flat body.

Trolleys

Part No.	Description	Length		Width		Fits rail
		in	mm	in	mm	
INCAR1-CURVE*	Single trolley with swing shackle (fall arrest/rope access)	3 7/16	87	3 5/32	80	IN1643, IN1650, INR27.LS
INCAR2-CURVE*	Single trolley with swivel shackle (fall arrest)	3 7/16	87	3 5/32	80	IN1643, IN1650, INR27.LS

*To order black hardcoat-anodized, add (BLACK) to end of part number.

Rail

Part No.	Description	Material	Weight kg/m	Bend radius cm
INR27-CURVECONCAVE.LS	Long-span rail with concave curve**	Anodized aluminum	1.7	63
INR27-CURVECONVEX.LS	Long-span rail with convex curve**	Anodized aluminum	1.7	63
INR27-CURVEFLAT.LS	Long-span rail with flat curve**	Anodized aluminum	1.7	40

**Only INCAR1-CURVE and INCAR2-CURVE trolleys can run on 90° curves.

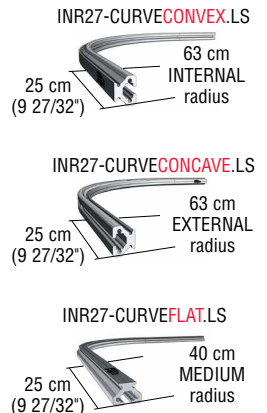

HARKEN INDUSTRIAL EXCEPTION: The Access Rail system may be used for human suspension and fall arrest.



WARNINGS AND INSTRUCTIONS. You must carefully read, understand, and follow all of the warnings and instructions in the manual provided by Harken Industrial in order to avoid an accident. Never, under any circumstances, exceed the maximum number of people working simultaneously on a span.

R27 LONG-SPAN ACCESS RAIL FOR METAL ROOFS

Complete solution for mounting rail on corrugated metal roofs

Metal roofs are becoming more popular because of the low costs to manufacture and maintain. The Harken Industrial™ complete solution for attaching access rail to corrugated metal

roofs provides a way to keep workers secure. The brackets can be as much as 3 m (9.8') apart when using Harken Industrial's R27 Long Span Access Rails.

Roof construction specifications:

Standard steel sheet: minimum thickness 0.6 mm (0.024")

Steel sandwich panel: minimum thickness 0.4 mm (0.02")

Aluminum sandwich panel: minimum thickness 0.6 mm (0.024")

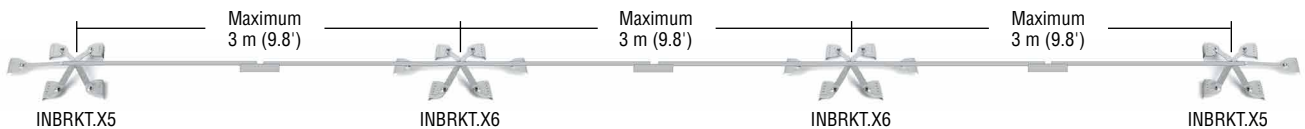

Proven trolley assembly
This system uses the proven R27 ball bearing trolley assembly for freedom of movement under load.

Durable, waterproof materials
Sandblasted stainless steel brackets are mounted with included silicone gaskets for a water-tight seal.

Customizable for easy installation
Bracket plates can be customized to fit different roof profiles. Rivets are included for easy installation. Supply dimensions in diagram above when you order.

Part No.	Description	Material	Fasteners	Includes
INBRKT.X5	End bracket for metal roof	Stainless steel	SFS BULB-TITE® rivets 5.2 x 17.5 mm	1 bracket, 45 rivets, silicon gaskets, and 1 single-hole insert
INBRKT.X6	Middle bracket for metal roofs	Stainless steel	SFS BULB-TITE® rivets 5.2 x 17.5 mm	1 bracket, 54 rivets, silicon gaskets, and 1 single-hole insert

The R27LS is certified to support as many as four users on a single span. The rail can be installed with a span between brackets of up to 3 m (9.8').

CE Certified



The Harken Industrial 27 mm Long-Span Access Rail system can be used for human suspension. The rails are tested by Notified Body, CE compliant under EN795:2012 Type D and CEN/TS 16415:2013. The trolleys are tested by Notified Body, CE certified under EN795:2012 Type B.

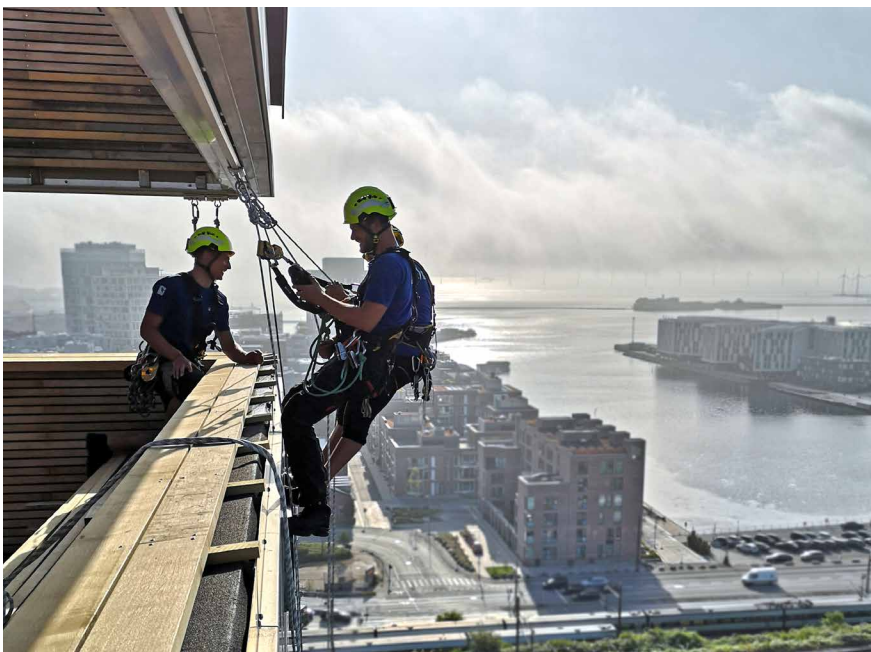



TIGHT RADIUS SYSTEM TR31



Work securely and safely

The TR31 Tight Radius rail and trolley system is designed to work as a movable anchorage point for fall restraint applications. Straight rails can be bent to accommodate directional changes up to a 350 mm (13.8") radius. Machined corners up to 200 mm (7.9") radius bends are available for both horizontal and vertical transitions.



Trolley design

Trolleys are strong, tested to 1200 kg (2645 lb) and comply with 2 x MCA requirements. They are compact for minimal intrusion on narrow deck and restricted work areas. Trolleys are multidirectional load capable. Anodized for maximum corrosion resistance. Delrin® low-friction rollers require no lubrication. Rollers are fully supported on both ends for smooth movement.



Rail design

Rails are made of high-strength, marine grade 6061-T6 aluminum and are anodized for maximum protection. Designed for countersunk M10 fasteners for flush mounting. The rails can be used for vertical and horizontal operating planes with unsupported spans as long as 1.3 m (4.3').



Brake trolley design

Screwpin on trolley keeps it in position when not in use. Delrin® low-friction rollers require no lubrication. Rollers are fully supported on both ends for smooth movement.

How does it work?

The TR31 continuous rail and trolley system allows a fully-harnessed crew member, safely tethered to the trolley, to move freely along the rail during inspection and maintenance, or when assisting in pilot transfer. Rails can be either surface or stanchion mounted and are designed so the user never has to unhook and rehook the tether as he moves around the deck.

Installation and maintenance

The system can be installed either at initial build or as a retrofit. Flush clean with fresh water and mild detergent. It is important to clean the trolley. Excessive build-up of grease, dirt, and salt will affect trolley movement.



IN210.CLEAR

IN212.CLEAR

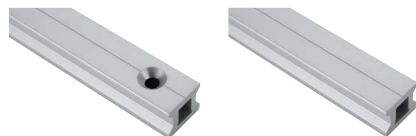

IN209.3M.CLEAR

IN213.3M.CLEAR



H-73945

IN211

548

Corners - Horizontal bend



90°

IN201.CLEAR



60°

IN204.CLEAR



45°

IN205.CLEAR



30°

IN203.CLEAR

Corners - Vertical bend



IN202.CLEAR



IN207.CLEAR



IN208.CLEAR



IN206.CLEAR

TR31 Trolleys

Part No.	Description	Length		Width		Weight	
		in	mm	in	mm	lb	g
IN210.CLEAR*	Trolley	2.63	66.8	2.06	52.32	0.56	254
IN212.CLEAR*	Brake trolley	2.73	69.2	2.6	66.04	0.60	270

*To order black hardcoat-anodized, remove .CLEAR from end of part number.

TR31 Rail & Accessories

Part No.	Description	Bend information	Bend radius mm	Arc length**		Weight		Fasteners mm
				ft/in	m	lb	g	
IN209.3M.CLEAR*	Straight rail section	Straight	200	9' 10 1/16"	3	8.47	3840	M10
IN213.3M.CLEAR*	Straight rail section without holes	Straight	200	9' 10 1/16"	3	8.49	3850	
IN203.CLEAR*	Corner rail	Horizontal 30°	200	6 11/16"	0.17	0.57	260	M10
IN205.CLEAR*	Corner rail	Horizontal 45°	200	8 11/16"	0.22	0.77	350	M10
IN204.CLEAR*	Corner rail	Horizontal 60°	200	10 5/8"	0.27	0.98	440	M10
IN201.CLEAR*	Corner rail	Horizontal 90°	200	14 3/16"	0.36	1.39	630	M10
IN206.CLEAR*	Corner rail	Vertical 30°	200	7 1/16"	0.18	0.60	270	M10
IN208.CLEAR*	Corner rail	Vertical 45°	200	9 1/16"	0.23	0.81	370	M10
IN207.CLEAR*	Corner rail	Vertical 60°	200	11"	0.28	1.03	470	M10
IN202.CLEAR*	Corner rail	Vertical 90°	200	15 5/16"	0.39	1.46	660	M10
548	Endstop set (2.83"/71.8 mm)					0.13	60	
IN211	Splice link with 10 mm holes					0.051	23	
H-73945	Splice link with 10 mm threaded holes					0.053	24	

*To order black hardcoat-anodized, remove .CLEAR from end of part number. ** Arc length is to the inside of the radius.



TROLLEY & RAIL SYSTEMS

Smooth & simple systems for moving loads



Low-friction linear movement

Harken Industrial™ trolley and rail systems provide a simple low-maintenance way to move loads smoothly. Rails and trolleys provide a low-friction rolling solution under both compression and tension loads.

Trolleys feature recirculating ball bearings housed in strong, lightweight, corrosion-resistant aluminum for dependable, low-friction linear travel.



Low friction, smooth rolling

Torlon® or Delrin® ball bearings reduce friction to move loads easily, and require no lubrication. Stainless wire guides keep ball bearings captive, allowing trolleys to be easily removed for maintenance.

Harken Industrial trolleys are designed with an open-ball race for easy maintenance. The rail can be bent to various radii, allowing the trolley to run freely.

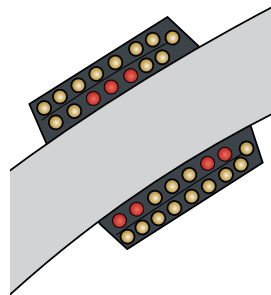

Curved rail

Rails can be bent to suit various applications. Minor bends can be made when the rail is installed. If the rail requires greater bend, Harken Industrial can provide horizontal, vertical, or compound curves to specification. Contact Harken Industrial for more details.



Multiple Mounting Options

These include shackle connectors and threaded holes for direct mounting.

Trolleys

Harken Industrial™ trolleys are available in a variety of sizes and configurations. Use for adjustable seat rail systems, window-washing apparatus, hoisting and moving stage equipment, and material handling.

Trolleys come with shackles, toggles, or tapped holes for connecting rope or pulleys. Pinstops available on some models.



Shackle



Toggle



Tapped holes



Part No.	Description	Length		Width		Height		Weight		Max rated load kN	Breaking load kN
		in	mm	in	mm	in	mm	oz	g		
R13											
2700	Trolley w/shackle	2 3/16	56	1 9/16	40	1 7/32	31	1.76	50	1.4	6.7
IN6707	Trolley w/2x M4 tapped holes	2 3/16	56	1 9/16	40	3/4	19	2.01	57	0.7	2.8
IN6707.HL	High-load trolley w/2x M4 tapped holes	2 3/16	56	1 9/16	40	3/4	19	2.01	57	1.4	6.7
IN8187	Trolley w/2x 1/4-20 tapped holes	2 3/16	56	1 9/16	40	3/4	19	1.98	56	0.7	2.8
IN8187.HL	High-load trolley w/2x 1/4-20 tapped holes	2 3/16	56	1 9/16	40	3/4	19	1.98	56	1.4	6.7
IN15069	Trolley w/3x imperial tapped holes	2 3/16	56	1 9/16	40	11/16	18	1.98	56	0.7	2.8
IN10569.HL	High-load trolley w/3x imperial tapped holes	2 3/16	56	1 9/16	40	11/16	18	1.98	56	1.4	6.7
IN11067	Trolley w/6 mm threaded stud	2 3/16	56	1 9/16	40	1 7/8	48	2.33	66	0.7	2.8
R22											
2726	Trolley w/shackle	2 7/8	73	2 1/4	57	1 11/16	43	4.64	132	2.2	8.9
2727	High-load trolley w/shackle	2 7/8	73	2 1/4	57	1 11/16	43	4.64	132	2.8	11.1
IN7986	Trolley w/2x 1/4-20 tapped holes	2 7/8	73	2 1/4	57	15/16	24	4.83	137	2.2	8.9
IN7986.HL	High-load utility trolley	2 7/8	73	2 1/4	57	15/16	24	4.83	137	2.8	11.1
IN8473.HL	High-load trolley w/2x M8 tapped holes	2 7/8	73	2 1/4	57	15/16	24	4.80	136	2.8	11.1
IN8418	Trolley w/2x M6 tapped holes	4 1/8	105	2 1/4	57	15/16	24	7.05	200	2.8	11.1
IN8306	Trolley w/2x 1/4-20 tapped holes and central threaded pinstop	2 7/8	73	2 1/4	57	2 15/16	75	5.86	166	2.8	11.1
IN9585	Trolley w/2x M6 tapped holes and pinstop	4 1/8	105	2 1/4	57	15/16	24	6.10	173	2.8	11.1
IN126	Slider trolley w/2x M6 tapped holes and threaded pinstop	3 5/16	84	1 1/4	33	2 1/2	65	3.92	111	2.5	10
IN10430	Trolley w/3x imperial tapped holes	2 7/8	73	2 1/4	57	15/16	24	4.55	129	2.8	11.1
IN143	Slider trolley w/2x M6 counter bored holes	3 5/16	84	1 1/4	33	3/4	19	3.35	95	2.5	10
IN146.SP1	Slider trolley w/2x M6 tapped holes	3 5/16	84	1 1/4	33	3/4	19	3.46	98	2.5	10
R27											
T2701B	Trolley w/shackle	4 1/4	108	2 3/4	70	2	50	11.04	313	5.6	22.2
T2701B.HL	High-load trolley w/shackle	5 3/16	132	2 3/4	70	2	50	12.48	354	5.6	22.2
C8261	Non-CB trolley w/shackle	5 3/16	132	2 3/4	70	2	50	14.66	416	5.6	22.2
IN9819	Trolley w/3x M8 tapped holes	5 3/16	132	2 3/4	70	1 1/16	28	13.88	393	5.6	22.2
IN1625	Trolley w/6x tapped holes	5 3/16	132	2 3/4	70	1 1/16	28	10.4	294	5.6	22.2
IN152	Slider trolley w/3x M8 tapped holes	5	127	1 5/8	42	1 5/64	27	8.22	233	6.5	26
IN153	Slider trolley w/3x M8 tapped holes and pinstop	5	127	1 5/8	42	1 5/64	27	8.68	246	6.5	26
R32											
T3201B	Trolley w/shackle	5 3/8	136	3 11/32	85	2 5/8	73	20	567	7.8	31.1
T3201B.HL	High-load trolley w/shackle	7 7/16	188	3 11/32	85	2 5/8	73	24	680	10	40
T3204B	Trolley w/2 toggles	9 1/8	231	3 11/32	85	3 1/2	89	55	1559	11.1	44.5
IN104	Trolley w/plain top	9 1/8	231	3 11/32	85	3 1/2	89	38	1080	11.1	44.5
IN148	Trolley w/6x metric tapped holes	7 7/16	188	3 11/32	85	2 5/8	73	22	621	10	40

Clear-anodized trolleys available by special order. Add: '.CLEAR' to end of part number.



Maximum rated loads are 4:1 coefficient ratio of the breaking load. Human suspension applications require 10:1 ratio.

WARNINGS AND INSTRUCTIONS: You must carefully read, understand, and follow the warnings and instructions in the manual provided by Harken Industrial in order to avoid an accident. For applications where trolleys are in compression please consult with a Harken Industrial Representative. Never, under any circumstances, exceed the rated load limit.

Rail

The rail is a simple, strong, low-maintenance system on which the load travels. Select size and length of rail (sizes listed by width measurement of top of rail in millimeters). Choose low-beam rail if it will be supported for the entire length. Choose high-beam rail for spanning unsupported spaces.

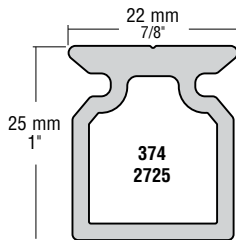
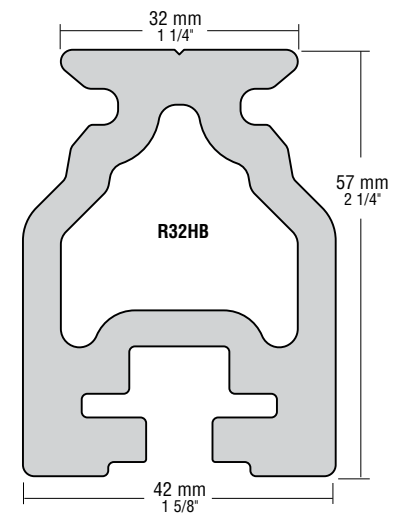
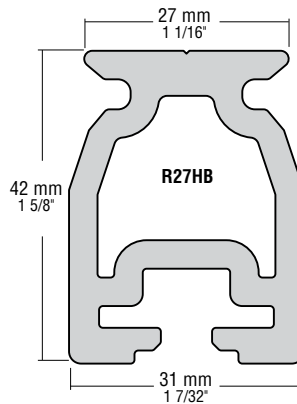
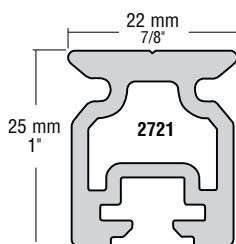
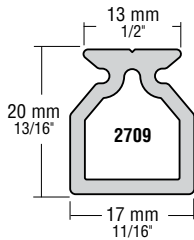
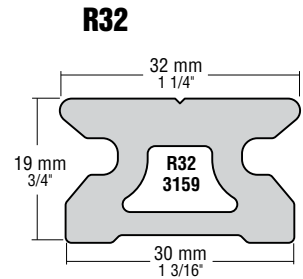
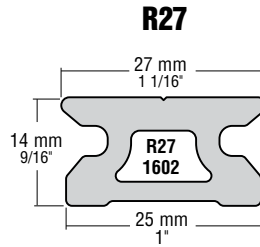
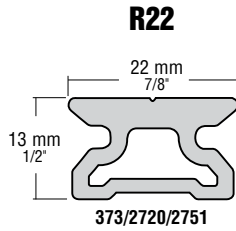
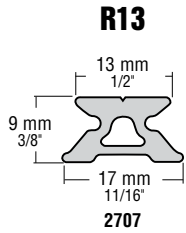

Part No.	Description	Length		Mounting hole spacing		Fasteners	
		ft/in	m	in	mm	in	mm
R13							
2707.2M	Low-beam metric rail	6' 7"	2	1 31/32	50	#8 FH	4 FH
2709.2M	High-beam metric rail	6' 7"	2	3 15/16	100	#8 FH	4 FH
R22							
2720.3M	Low-beam metric rail	9' 10 1/16"	3	3 15/16	100	#10 FH	5 FH
2725.3.6M	High-beam metric rail	11' 9 3/4"	3.6	3 15/16	100	#10 FH	5 FH
2721.3.6M	High-beam variable hole spacing rail	11' 9 3/4"	3.6	Slide bolt	Slide bolt		5 HH
373.6	Low-beam imperial rail	6'	1.83	4	102	#10 FH	5 FH
374.6	High-beam imperial rail	6'	1.83	4	102	#10 FH	5 FH
R27							
R27.3M	Low-beam pinstop metric rail	9' 10 1/16"	3	3 15/16	100	5/16 FH	8 FH
R27.3.6M	Low-beam pinstop metric rail	11' 9 3/4"	3.6	3 15/16	100	5/16 FH	8 FH
R27.6M	Low-beam pinstop metric rail	19' 8 1/4"	6	3 15/16	100	5/16 FH	8 FH
R27HB.3.6M	High-beam variable hole spacing rail	11' 9 3/4"	3.6	Slide bolt	Slide bolt	1/4 HH	6 HH
1602.8	Low-beam imperial rail	8'	2.44	4	102	1/4 FH	6 FH
R32							
R32.3M	Low-beam pinstop metric rail	9' 10 1/16"	3	3 15/16	100	3/8 FH	10 FH
R32.6M	Low-beam pinstop metric rail	19' 8 1/4"	6	3 15/16	100	3/8 FH	10 FH
R32HB.3.6M	High-beam variable hole spacing rail*	11' 9 3/4"	3.6	Slide bolt	Slide bolt	5/16 HH	8 HH
3159.8	Low-beam imperial	8'	2.44	4	102	5/16 FH	8 FH

*Contact Harken Industrial™.



Low-beam



High-beam

FAST FACTS

Harken Industrial trolley and rail systems can be fitted retroactively

The simplicity of the systems allows them to be installed easily on existing structures.

Harken Industrial trolley and rail systems can accommodate a radius

Rails can be bent to suit application specifications. Contact Harken Industrial for information.

Two Harken Industrial rail systems are certified for human suspension

The R27 and the R32 Access rail systems are certified for human suspension. Please see page 33 for more information.

Harken Industrial trolley and rail systems are durable and easy to maintain

Harken Industrial's strong, lightweight trolleys and rails are specifically designed to resist the corrosive effects of an outdoor environment. Stainless steel wire guides hold ball bearings captive when the trolley is removed from the rail. An open-ball race makes trolleys easy to clean with soap and water.

APPLICATIONS

Simple to use and ideal for moving heavy loads

Harken Industrial™ trolley and rail systems can be used in a wide range of applications:

- Construction
- Film production
- Renewable energy
- Architectural
- Facilities management
- Utilities, oil & gas
- Vessel maintenance
- Exercise
- Material handling
- Transportation



WARNINGS AND INSTRUCTIONS: You must carefully read, understand, and follow all of the warnings and instructions in the manual provided by Harken Industrial in order to avoid an accident. Never, under any circumstances, exceed the maximum rated load.

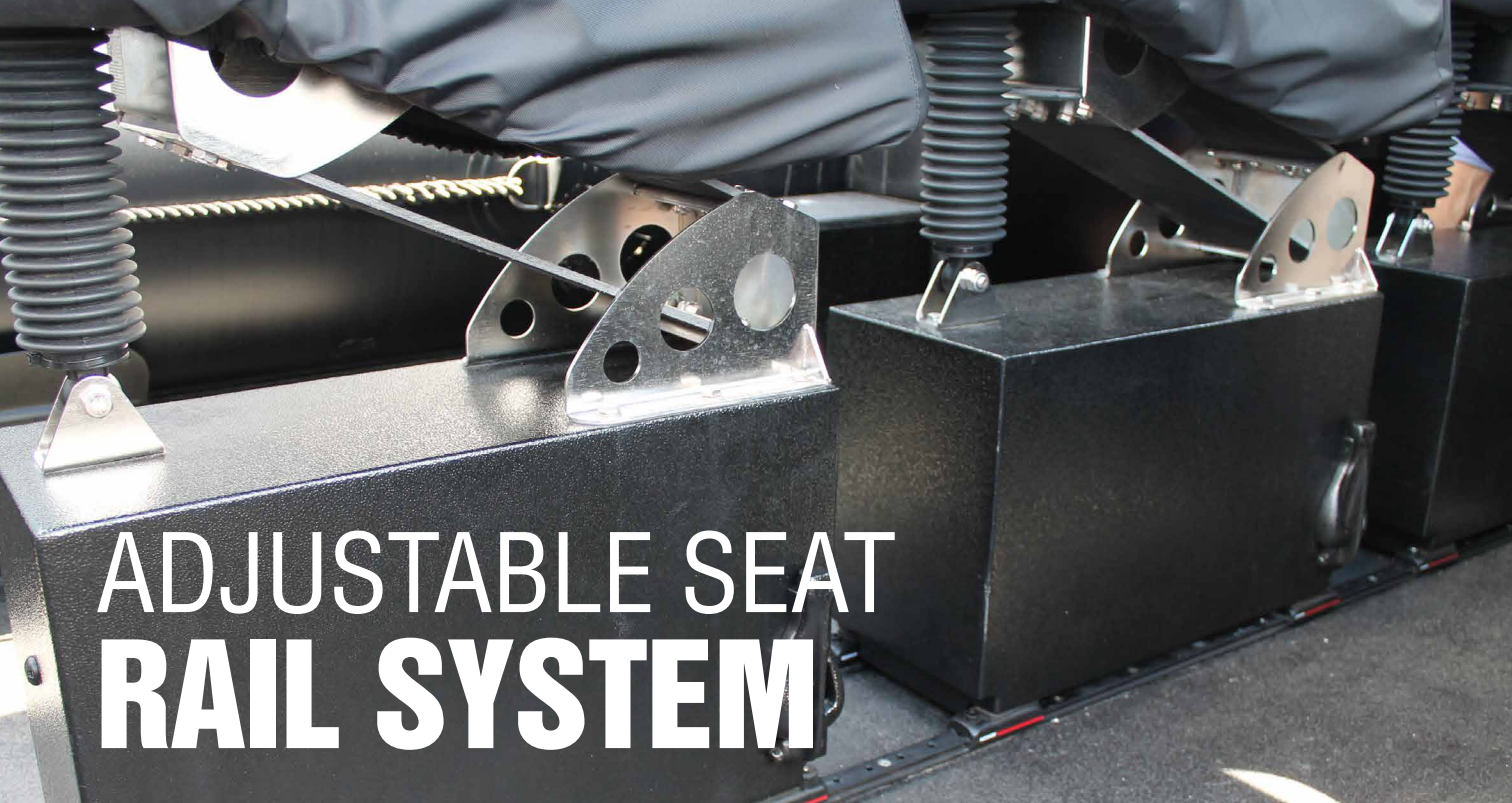

ADJUSTABLE SEAT RAIL SYSTEM

A better rail system for seat mounting

This system is specifically designed for the marine environment, giving you a flexible cockpit layout with fast, hassle-free reconfiguration. These systems meet HSC regulations. Trolleys can be fitted to dive tank racks, weapons racks, deck boxes, etc.



Trolley design

Trolleys are strong – 22 mm system tested to 20 kN (4496 lb) and 27 mm system tested to 25 kN (5620 lb). They are compact resulting in minimum intrusion on the cockpit sole. The trolleys are fitted with pinstops for secure, quick and easy adjustments. The black hardcoat-anodized finish ensures maximum corrosion resistance.



Rail design

Rails are made of high-strength, marine grade 6061-T6 aluminum and are anodized for maximum protection. Pinstop holes provide maximum flexibility for seat spacing. Countersunk fasteners for flush mounting. The underside of the rail is recessed to allow for mastic sealant.



Delrin® insulating sliders

Low-friction sliders require no lubrication because there's no metal-to-metal contact. The rollers provide smooth movement with minimum rattle.



How does it work?

Seats are mounted on four trolleys that run on parallel rails. Two of the trolleys have pinstops that fit into the holes in the rails. Two trolleys are free sliding.

To adjust the trolley location, simply raise the two pinstops and slide to a new location.

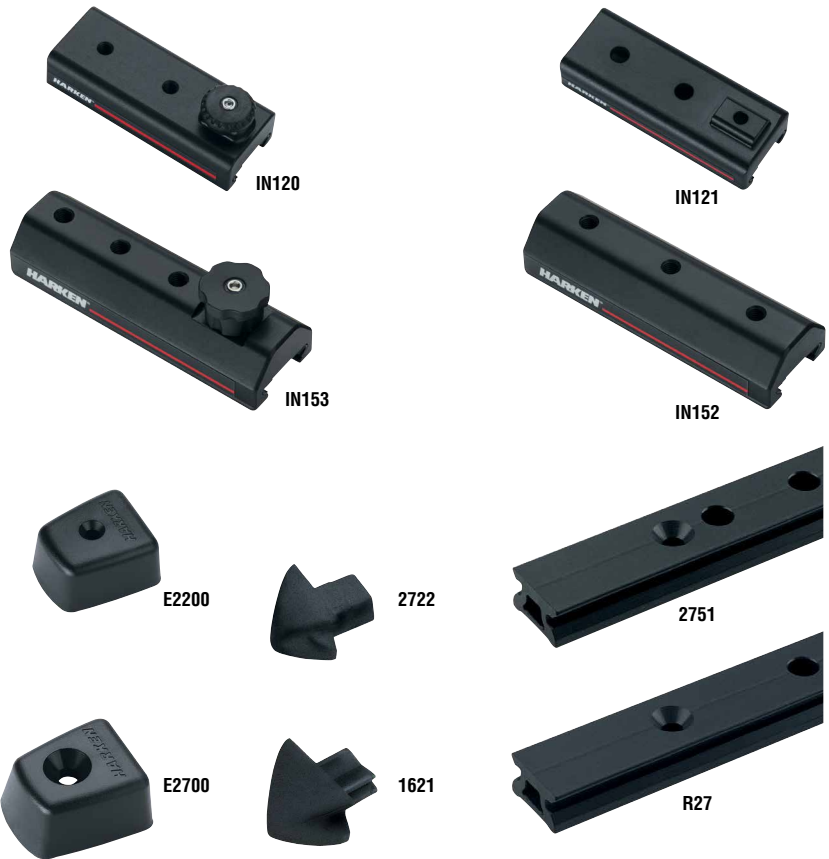

Trolleys

Part No.	Description	Length		Width		Weight		Fits rail
		in	mm	in	mm	lb	g	
22 mm								
IN120	Slider trolley with pinstop	3.3	84	1.29	33	0.208	94.68	2751
IN121	Slider trolley with plain top	3.3	84	1.29	33	0.208	94.68	2751
27 mm								
IN152	Slider trolley w/3x M8 tapped holes	5	127	1 5/8	42	0.51	233	R27
IN153	Slider trolley w/3x M8 tapped holes and pinstop	5	127	1 5/8	42	0.54	246	R27

Rail & Accessories

Part No.	Description	Length		Mounting hole spacing*		Fasteners		Endstop	Trim cap	Splice link
		ft/in	mm	in	mm	in	mm			
22 mm										
2751.600MM	Low-beam pinstop metric rail	1' 11 5/8"	0.6	3 15/16	100	#10 FH	5 FH	263/E2200	2722	2724
2751.1M	Low-beam pinstop metric rail	3' 3 3/8"	1	3 15/16	100	#10 FH	5 FH	263/E2200	2722	2724
2751.1.5M	Low-beam pinstop metric rail	4' 11 1/16"	1.5	3 15/16	100	#10 FH	5 FH	263/E2200	2722	2724
2751.2M	Low-beam pinstop metric rail	6' 6 3/4"	2	3 15/16	100	#10 FH	5 FH	263/E2200	2722	2724
2751.3.6M	Low-beam pinstop metric rail	11' 9 3/4"	3.6	3 15/16	100	#10 FH	5 FH	263/E2200	2722	2724
2722	Trim cap set									
E2200	Endstop set									
27 mm										
R27.1M	Low-beam pinstop metric rail	3' 3 3/8"	1	3 15/16	100	5/16 FH	8 FH	1522/E2700	1621	1619
R27.1.2M	Low-beam pinstop metric rail	3' 11 1/4"	1.2	3 15/16	100	5/16 FH	8 FH	1522/E2700	1621	1619
R27.1.5M	Low-beam pinstop metric rail	4' 11 1/16"	1.5	3 15/16	100	5/16 FH	8 FH	1522/E2700	1621	1619
R27.1.8M	Low-beam pinstop metric rail	5' 10 13/16"	1.8	3 15/16	100	5/16 FH	8 FH	1522/E2700	1621	1619
R27.2M	Low-beam pinstop metric rail	6' 6 3/4"	2	3 15/16	100	5/16 FH	8 FH	1522/E2700	1621	1619
R27.2.5M	Low-beam pinstop metric rail	8' 2 7/16"	2.5	3 15/16	100	5/16 FH	8 FH	1522/E2700	1621	1619
R27.3M	Low-beam pinstop metric rail	9' 10 1/16"	3	3 15/16	100	5/16 FH	8 FH	1522/E2700	1621	1619
1621	Trim cap set									
E2700	Endstop set									

*First mounting hole distance from end of track: 50 mm (1 31/32").

PULLEYS & BLOCKS



Harken Industrial pulleys facilitate low-friction pulling power for any fiber rope application. Designed to be as lightweight and small as possible for the load capacity, they are easy to transport and install.



The Kangshung face of Mt. Everest is revered as one of the most dangerous and remote routes to climb. Harken pulleys assisted in the first successful ascent.

To get supplies and other equipment needed for the expedition across the crevice and up the ledge, the climbing team created a winching system in which Harken pulleys served as

the dynamic mechanism that facilitated movement of the gear up and across the face.

On October 8, 1983, the team made the 8,848 m (29,028') ascent to the top of the world — a feat never before accomplished from the eastern face. **HARKEN PULLEYS MADE WHAT WAS WIDELY CONSIDERED TO BE IMPOSSIBLE, POSSIBLE.**

PULLEYS

Handle all sorts of load with ease



Harken Industrial™ has a solution for any pulling problem

Harken Industrial™ pulleys provide low-friction pulling power for any fiber-rope application. Designed to be as lightweight and small as possible for the load capacity, they are easy to transport and install. Sheave diameters range from 57 – 150 mm (2 1/4 – 5 15/16")

with options of single and double sheaves featuring ratchets, swivels, and beckets. All Harken Industrial pulleys are certified to EN13157 Machinery Directive for lifting goods and equipment. If you don't find a pulley that meets your needs here, contact us about our full range.



Carbo® Air® pulleys

These high-strength, lightweight pulleys are made of tough, reinforced composite. Free-running ball bearings run on curved races, efficiently dispersing load for a higher strength-for-size than flat races carry.



Classic Midrange Pulleys

These robust pulleys are ideal for handling high loads. Free-running Delrin® ball bearings roll on flat races to allow fast haul and release under high or low loads.

Hexaratchet® versions grip loaded ropes, relieving holding loads, while maintaining quick ease and haul with complete control. A switch on the side engages and disengages the ratchet mechanism.



Black Magic® Air® pulleys

With high strength-to-weight ratios and free-rolling, high-load roller bearings, Black Magic Air pulleys handle high dynamic and static loads where friction is an issue.



CE Certified

Certified under EN13157 Machinery Directive for lifting goods and equipment.



Clearly labeled

Pulleys are engraved with part number, serial number, CE, EN test number, and max rated load (MRL).

APPLICATIONS & MAINTENANCE

Simple to use and ideal for diverse applications

Harken pulleys can be used in rope-handling applications across many industries:

- Load towing/securing
- Theatrical
- Cable laying
- Stunt work

Maintenance is easy

The simple construction requires no lubrication. Simply flush with fresh water to keep bearings free rolling.

FAQS

Q: What are my options if I need a pulley that isn't certified?

A: Harken Industrial can CE certify additional pulleys in response to demand. If you need a pulley that is not listed, please contact info@harkenindustrial.com.

Q: Can these pulleys be used with wire rope?

A: Typically the answer is no. Contact Harken Industrial to discuss your application.

Q: What does Max Rated Load mean?

A: This is the maximum load for which the equipment is designed by the manufacturer as defined by the certification standard.

Range

All Harken Industrial™ pulleys listed below are CE certified for use with fiber rope.

Part No.	Description	Sheave Ø		Length		Weight		Shackle pin Ø		Max fiber rope Ø*		Max rated load	
		in	mm	in	mm	lb	g	in	mm	in	mm	lb	kN
Carbo													
IN2660	Single Carbo swivel	2 15/16	75	5 3/8	137	0.43	195	1/4	6	9/16	14	224	1.25
IN2661	Single Carbo swivel w/bucket	2 15/16	75	6 1/2	165	0.47	214	1/4	6	9/16	14	224	1.25
IN2662	Double Carbo swivel	2 15/16	75	6	152	0.88	402	5/16	8	9/16	14	562	2.5
Classic Midrange													
IN1540	Single Midrange	3	76	6 1/8	156	0.81	367	5/16	8	9/16	14	1124	5
IN1544	Double Midrange	3	76	7 1/2	191	1.59	723	5/16	8	9/16	14	1573	7
IN1545	Double Midrange w/bucket	3	76	8 1/2	216	1.65	751	5/16	8	9/16	14	1573	7
IN1549SSP	Single Midrange Hexaratchet	3	76	6 1/8	156	0.88	397	5/16	8	9/16	14	1124	5
Black Magic													
IN3226	Single Black Magic swivel	2 1/4	57	4 11/16	119	0.34	154	1/4	6	7/16	12	1124	5
IN3215	Single Black Magic swivel	2 1/4	57	4 11/16	119	0.34	152	1/4	6	7/16	12	1124	5
IN3217	Double Black Magic swivel	2 1/4	57	5 3/16	132	0.74	336	5/16	8	7/16	12	1574	7
IN3214	Single Black Magic loop**	2 1/4	57	3	76	0.2	92			7/16	12	674	3
IN3243	Single Black Magic swivel	2 15/16	75	5 1/8	129	0.74	335	5/16	8	9/16	14	1348	6
IN3231	Single Black Magic swivel	2 15/16	75	5 1/8	129	0.73	331	5/16	8	9/16	14	2248	10
IN3246	Single Black Magic swivel	3 15/16	100	8	203	1.37	623	3/8	10	5/8	16	3372	15
IN3256	Single Black Magic swivel	4 15/16	125	10	254	2.33	1058	1/2	12	3/4	19	4495	20
IN3255	Single Black Magic loop**	4 15/16	125	6	163	1.48	674			3/4	19	4495	20
IN3262	Single Black Magic swivel	5 15/16	150	12	305	4.05	1840	5/8	16	1	25	6969	31

*Max wire rope Ø is dependent on wire construction and application. Please contact Harken Industrial for information.

**Loop not included.



Rated loads are 4:1 coefficient ratio of the type test load.

WARNINGS AND INSTRUCTIONS. You must carefully read, understand, and follow all of the warnings and instructions in the manual provided by Harken Industrial in order to avoid an accident. Never, under any circumstances, exceed the maximum rated load.

PURCHASE SYSTEMS

Making light work of heavy loads

Lightweight, compact, low-friction, certified

Harken Industrial™ purchase systems increase operation strength, facilitating low-friction pulling power in a wide variety of pulling/lifting operations. Systems can be used on

their own, or easily combined with an existing system for tensioning, deviation, or casualty transfer. Purchase systems come fully rigged with tamper-evident terminations.



Low-friction sheave

Delrin® ball bearings provide low-friction, easy rope release under load. Ball bearings are UV-stabilized for maximum protection.



Ball bearing cam cleats

Harken Industrial ball bearing cam cleats hold rope securely and release easily under load. Multiple rows of ball bearings reduce friction. The cam's V-shape guides rope for easy entry.



Tamper evident

Purchase systems are supplied prereeved and fully assembled. The securing knot is sealed to prevent irreparable damage to the system.



Pre-stretched polyester rope

The purchase systems use polyester based rope in various sizes. The polyester braided covers are UV and abrasion resistant.



Safety compliance

Harken Industrial™ purchase systems are serial numbered for full traceability. The 443.DRPS is supplied with an individual proof test certificate.

APPLICATIONS & MAINTENANCE

Simple to use in load-assist applications

Harken Industrial purchase systems are used by emergency services and rescue personnel to help transfer loads and individuals from working ropes to alternates. The system is also used to transfer loads in deviation, and to take the load when lifting inanimate objects.

Maintenance is easy

To clean, simply flush pulleys with fresh water. As with all equipment, check regularly to make sure it is in good working order. Check rope for chafe and wear. Make sure tamper-evident seals are intact.



IN2624 443.2141 443.DRPS

Contact Harken Industrial in the UK for purchase system sales/information.

Part No.	Description	Range of travel		Max rated load for goods/ equipment (BL/4)		SWL for human suspension (BL/10)		Individual proof-tested	
		ft	m	lb	kN	lb	kN	lb	kg
IN2624	CE 4:1 purchase system	6.5	2	445	2				
443.DRPS.3M	CE 6:1 diver recovery purchase system - 3 m throw*	9.8	3	937	4.25	375	1.7	660	300
443.DRPS.6M	CE 6:1 diver recovery purchase system - 6 m throw*	19.6	6	937	4.25	375	1.7	660	300
443.DRPS.9M	CE 6:1 diver recovery purchase system - 9 m throw*	29.5	9	937	4.25	375	1.7	660	300
443.2141.3M	CE 6:1 MOB purchase system - 3 m throw*	9.8	3	900	4	375	1.7		
443.2141.6M	CE 6:1 MOB purchase system - 6 m throw*	19.6	6	900	4	375	1.7		
443.2141.9M	CE 6:1 MOB purchase system - 9 m throw*	29.5	9	900	4	375	1.7		

*Custom lengths available from 1 to 25 m (3.3 – 82'). Rope color may vary.

FAST FACTS

Harken industrial purchase systems are CE certified

CE certified under: EN13157 (Machinery Directive) for lifting goods and equipment.

Harken Industrial purchase systems can be used for human suspension for rescue

IN2624 purchase systems are intended for non-live loads but can be used to help transfer live loads in rescue situations. The 443.DRPS Diver Recovery and the 443.2141 MOB purchase systems can be used for human suspension when a safety factor of 10 is applied and used in conjunction with fall protection, in accordance with local standards and regulations.

Purchase system modifications must be made by Harken Industrial or an approved service center

Any modifications made to Harken Industrial purchase systems will result in the loss of certification. Modifications and repairs should only be done by Harken Industrial or an approved service center.

Purchase systems are available in multiple lengths and configurations

Purchase systems are available with different ranges of travel from 1 m (3.3') up, with 4:1 or 6:1 mechanical advantage. All systems are CE certified under EN13157.

Purchase systems come with shackle connectors offering attachment versatility

All listed purchase systems are supplied with shackle connectors; accessories can be offered for some solutions.

Please contact Harken Industrial-UK at +44 (0)1590 689122 for more details.



Maximum rated load is calculated from a 4x safety factor from break load for load lifting and pulling applications; marked in accordance with the Machinery Directive and EN13157:2004+A1:2009 Standard.

WARNINGS AND INSTRUCTIONS. You must carefully read, understand, and follow all of the warnings and instructions in the manual provided by Harken Industrial in order to avoid an accident. Never, under any circumstances, exceed the maximum rated load.



OCEANIC CABLE BLOCK

Safely leading data cable & towed arrays overboard



Aligns the load for optimized cable tracking

Harken Industrial™ Oceanic Cable blocks are used on research vessels to safely lead data cables and towed objects overboard. At only 19.3 kg (42.5 lb), the 500 mm (20") sheave-diameter block is light enough to align to the load, optimizing cable tracking.



Durability

Sideplates are constructed of hard-coat-anodized 6061-T6 aluminum for strength, durability, and corrosion resistance. They are PTFE-coated for a smooth surface.



Design

The block's wide throat allows passage of data cable terminals. The sheave's durable, lightweight Nylatron® material has high mechanical stiffness, resists static electricity, and has excellent wear resistance. Helicoils add strength while plastic isolators are used to minimize corrosion between aluminum and stainless steel.



Large diameter sheave

The block's open center helps move the center of gravity toward the shackle, improving the block's ability to align with the load. The sheave's groove detailing can be designed to suit specific data cable diameters.



Bearings

Delrin® roller bearings are housed in a center cage to keep them parallel for low-friction efficiency. The large-diameter bearing cage reduces friction and spreads the load. Captive Torlon® ball bearings handle sideloads.



Options

The block is designed to work with an optional magnetic Hall Effect Sensor.

FAST FACTS

The Oceanic Cable block is UNOLS safety standard compliant

The block complies with UNOLS Research Vessel Safety Standard, 10th Edition—2015.

Harken Industrial provides a Maximum Capability Document for the Oceanic Cable block

Please contact Harken Industrial to obtain it.

Oceanic Cable blocks offer high cable payout speed

The Oceanic Cable block's maximum pay out rate is 60 m/min (196 ft/min).

The Oceanic Cable block offers long operational lifespan

Harken has serviced 10-year-old blocks still in use. Regularly flushing the blocks with fresh water will help extend their life before service is required.

Custom sizes can be designed to suit cable requirements

The sheave groove detailing can be designed to suit specific cable diameters. Please contact Harken Industrial your requirements for a quote.

APPLICATIONS & MAINTENANCE

Oceanographic research

The Oceanic Cable block is used by Woods Hole Oceanographic Institute, University of Rhode Island (USA), and University of Alaska – Fairbanks oceanographic research departments, as well as many other research organizations.

Maintenance is easy

Flushing the block with fresh water after use will keep the dry-running bearings free rolling. If further maintenance is required, one hex wrench is all you need for disassembly. All the bearings are captive, so no need to worry about losing parts.

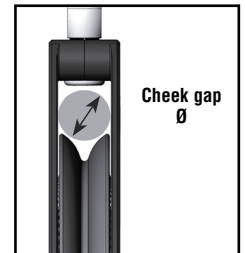

Part No.	Sheave Ø		Cheek gap Ø		Cable Ø		Weight		Root Ø		Max rated load	
	in	mm	in	mm	in	mm	lb	kg	in	mm	lb	kN
IN9417	29.52	750	4	101.6	0.75	19	150	68	26.5	673.1	39500	175.7
IN8355	20	500	2.25	57	0.375	9.5	42	19	17.965	456.31	19000	84.5
IN8260	20	500	2.25	57	0.25	6	42	19	17.75	450.85	19000	84.5
IN6989.590	20	500	2.25	57	0.59	15	42	19	17.662	448.62	19000	84.5
IN6989	20	500	2.25	57	0.315	8	42	19	17.662	448.62	19000	84.5
IN12771.322	20	500	2.25	57	0.315	8	42	19	17.662	448.62	19000	84.5
IN11467.500	25.5	650	2.75	70	0.5	12	137	62.16	23	584.2	65000	290
IN11467.410	25.5	650	2.75	70	0.41	10.5	137	62.16	23	584.2	65000	290
IN11118.680	30.5	775	4	101.6	0.68	17	233	105.68	28	711.2	80000	355
IN11118.563	30.5	775	4	101.6	0.563	14	233	105.68	28	711.2	80000	355

Compliant with UNOLS Research Vessel Safety Standards, Appendix B * Freeze tolerant version

Delrin is a registered trademark of E. I. du Pont de Nemours and Company or its affiliates. | Torlon is a registered trademark of Solvay Advanced Polymers.



WARNINGS AND INSTRUCTIONS. The user must follow the manufacturer's instructions for each component of the system. These instructions must be provided to the user of this equipment. The user must read and understand these instructions before using this equipment. Manufacturer's instructions must be followed for proper use and maintenance of this equipment. Alterations or misuse of this equipment, or failure to follow these instructions, can result in serious injury or death.

MARINE RESCUE SYSTEMS



Harken Industrial manufactures C-Hero[®], portable man overboard rescue systems. Designed for workboats, they can be operated by one or two crew members.



“ **DECATUR MARINE FOUND THE C-HERO MAN OVERBOARD RECOVERY SYSTEM TO MEET EXPLICIT IMO STANDARDS** concurrent with Subchapter M life-saving equipment protocols.

— Phil Carmichael, Technical Director, Decatur Marine **”**



C-HERO[®] MOB RESCUE SYSTEM

Manufactured by Harken Industrial

Perform recoveries quickly and safely with this portable davit and rescue pole system

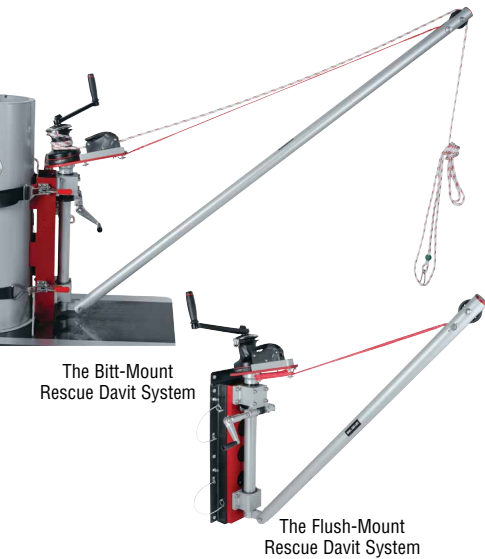

Proven 3-minute underway man overboard recovery. The portable lightweight man overboard lifting davit attaches to a bitt on a tugboat or is flush mounted on a flat surface on a workboat or ferry. The Rescue Davit system has straps and brackets on back of the unit to allow customization for any bitt. The davit is light enough for one person to retrieve and carry into position. It attaches in less than 30 seconds. One small person on deck can hoist a 158.8 kg (350 pound) person aboard using the included Radial winch. The boom is long

enough to clear tires and fenders; the worm gear controls the boom swing.

The flush-mount davit system (Part No. IN162) is designed for flat surfaces. The davit fits into a flush mount and is pinned with two tethered pins. The straps and clamps, feet on the back, and side stabilizers all come off so it will fit into the mount. The flush mount davit system comes with a reduced boom size. A mount for each side of the vessel is recommended.

Complete either system with the VR 12 Rescue Pole, sold separately.

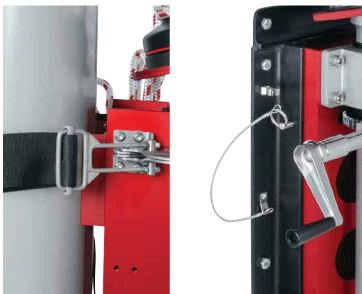

Attaches quickly

The bitt-mount system has adjustable straps with latch clamps for tightening. Straps and brackets on back of the unit allow customization for any bitt. The flush-mount system attaches with removable pins.



Adjustable feet and stabilizers

15.2 cm x 7.6 cm x 61 cm (6' x 3' x 24") aluminum tubing hold adjustable feet and stabilizers (not required for flush mount version).



Includes winch

Bitt-mount davit system comes with a Harken Industrial 20STA Radial winch, with optional upgrade to 35.2STA Radial 2-speed winch. The 35.2STA comes standard on flush-mount davit system. Both systems include rope brake and handle.



Long line to reach MOB

Boom is long enough to clear tires and fenders. Line is 13.7 m (45') long; 10 mm lift line with stopper ball and hook, 6 mm tension line.



Simple to operate

Worm gear and handle control boom swing.

ADDITIONAL FEATURES

- Rescue can be performed by one person
- Weight: Shown below by product
- Constructed of anodized marine grade aluminum and stainless steel to stand up to harsh marine environments
- 13.7 m (45') long, 10 mm lift line with stopper ball and hook, 6 mm tension line

Part No.	Description	Approximate overall size						Davit length		Weight	
		Height		Width		Depth		ft	m	lb	kg
		in	cm	in	cm	in	cm				
IN144.6FT	Rescue bitt-mount davit	81	206	18.5	47	15	38	6'8"	2	38	17.2
IN161	Rescue flush-mount bracket	26.3	66.8	10	25.6	2	5.1			5.5	2.5
IN162	Rescue flush-mount davit and IN161 bracket	52	132	16	41	14.5	37	4'3"	1.3	38	17.2

VR-12 Rescue Pole



Sturdy construction

Strap has a one-way slide-buckle that will not back out.



Simple operation

"V" cleat holds the lift line and keeps line out of the way.



Foam wrap

Pole's outer hoop is wrapped in foam for victim comfort and increased pole buoyancy. The hoop is wrapped in a red UV protectant reflective cover with SOLAS tape.

- The pole is foam-filled fiberglass tubing with a strong 60 x 60 x 1.9 cm (2' x 2' x 3/4") aluminum hoop that allows a single crew member to rescue a fully dressed person weighing up to 159 kg (350 lb). Can be easily and quickly re-rigged for additional rescues. The pole allows MOB to be pulled close to the boat before deploying the strap. Up to 3.6 m (12') reach.
- Rescue strap automatically detaches from holding blocks and snaps when being secured to the person by cinching the slide-buckle.

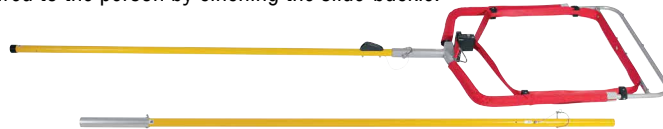

Part No.	Description	Pole length		Pole Ø		Weight	
		ft	m	in	cm	lb	kg
IN145	Vertical rescue pole	12	3.6	1.25	3.2	14.5	6.6



WARNINGS AND INSTRUCTIONS. You must carefully read, understand, and follow all of the warnings and instructions in the manual provided by C-Hero in order to avoid an accident. Never, under any circumstances, exceed the maximum rated load.

VR-12 RESCUE POLE WITH RECOVERY STRAP

No davit or winch required



The most affordable one-person rescue device for an unconscious MOB

On-deck crew members use the hand-held Rescue Pole to deploy the integral orange Rescue Strap over the MOB's head and under the arms for a vertical recovery. Those crew members then perform the recovery while remaining safe inside the bulwarks. The VR-12

Rescue Pole with Recovery Strap has two 2.5 cm (1") web straps, with 10 alternating handles that fasten together so that one or two persons can lift singly or together. This is a good system if you don't have a lifting davit. It can be used for up to 2.4 m (8') of freeboard with 1-2 persons.



For use by 1 or 2 persons

The Recovery Strap features two 2.5 cm (1") web straps with 10 alternating handles that fasten together allowing one or two persons to lift the man overboard out of the water.



Simple operation

Strap has a one-way slide-buckle that will not back out.

"V" cleat holds the lift line and keeps line out of the way.



Foam wrap

Pole's outer loop is wrapped in foam for victim comfort and increased pole buoyancy. The loop is wrapped in a red UV protectant reflective cover with SOLAS tape.



- The pole is foam-filled fiberglass tubing with a strong 60 x 60 x 1.9 cm (2' x 2' x 3/4") aluminum hoop that allows a single crew member to rescue a fully dressed person weighing up to 159 kg (350 lb).
- The pole allows MOB to be pulled close to the boat before deploying the strap. Up to 3.6 m (12') reach.
- Can be re-rigged easily and quickly to perform additional rescues.
- Fully upgradable for use with C-Hero® Rescue Davit.

Part No.	Description	Pole length		Pole Ø		Weight	
		ft	m	in	cm	lb	kg
IN147	Vertical Rescue Pole with Recovery Strap	12	3.6	1.25	3.2	17.5	7.9



WARNINGS AND INSTRUCTIONS. You must carefully read, understand, and follow all of the warnings and instructions in the manual provided by C-Hero in order to avoid an accident. Never, under any circumstances, exceed the maximum rated load.

COMPLEMENTARY HARDWARE



Harken Industrial offers a range of products to help make jobs easier, including permanent mount static attachments and efficient rope cleats.



STATIC ATTACHMENTS

Secure attachment and lashing points

Long-Lasting Strength and Durability



Harken Industrial's experience with rope handling on yachts has led to the development of a wide variety of attachment point products — from simple eyestraps to high-strength,

lightweight padeyes, to removable solutions. Other static attachments are available: eyestraps, fixed, removable, and folding padeyes.



IN689

Certification

EN795.2012 Class A, ANSI Z359.1 meets the requirements for human suspension according to BS7985:2009, SPRAT and IRATA guidelines, when used in pairs (except IN629).



IN647

Material benefits

The IN647, IN688, and IN689 anchors are 316 stainless. The IN627, IN629 and IN648 are 17-4 PH stainless. The IN647 has a mirror finish and is highly corrosion resistant. All are suitable for onshore and offshore installations.



IN688

Applications

Use as an anchorage device, allowing operators to work safely at height. Padeyes are perfect for mounting pulleys and can be used as attachment points where needed.

Part No.	Description	A		B		Fasteners		Max rated load* kN	Breaking load kN	Max number of users
		in	mm	in	mm	in	mm			
IN627	Round	2 1/4	57			1/4 FH	6 FH	8.75	35	2
IN629	Round	3 3/4	95			1/2 FH	12 FH	24	96	5
IN647	Round/polished	3	76			3/8 FH	10 FH	6	24	3
IN648	Round	3	76			3/8 FH	10 FH	17.5	70	3
IN688	Diamond	3 1/8	79	2	51	1/4 FH	6 FH	7.8	31	2
IN689	Diamond	3 7/8	98	2 5/16	59	5/16 FH	8 FH	15.75	63	3

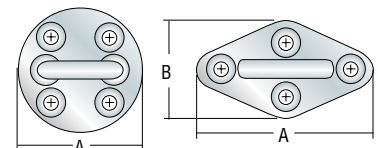

* = Breaking Load/4

BALL BEARING CAM CLEATS

Removes the risk of accidental release

Actual size

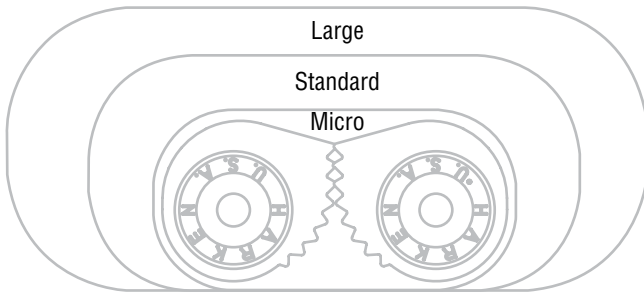

Engage, hold, release rope easily under load

Nothing beats Harken Industrial™ ball bearing cam cleats for a secure grip. Cleat engages rope with a downward snap of the wrist, keeps it where you put it, and releases quickly — even under high loads. Ideal for material handling and for use in exercise equipment and theatrical industries.

Stainless eyestraps, colored Flairleads, and fairleads guide rope, with some releasing and recleating up to 90 degrees; adapter plates ensure optimal cleating heights; wedge kits and risers improve cam angles.

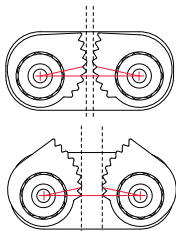

Protective tooth design

Each rope size is held securely by the most number of teeth which squeeze, rather than cut into the rope, greatly reducing wear.



Engage and release easily

Cam cleats engage under maximum tension, hold securely, and release instantly under load. Multiple rows of UV-stabilized ball bearings reduce friction. The cam's V-shape guides rope for easy entry.



Materials for different load ranges

Hard Lube-anodized aluminum or stainless steel for high loads. Also available in lightweight, UV-stabilized composite for low-load applications. Contact Harken Industrial for more information.

Part No.	Description	Rope Ø				Fasteners		Max rated load		Breaking load	
		in	mm	in	mm	in	mm	lb	kN	lb	kN
468	Micro aluminum cleat	3/32	2	1/4	6	#8 RH	4 RH	150	0.7	400	1.8
150	Standard aluminum cleat	1/8	3	1/2	12	#10 FH	5 FH	200	0.9	750	3.3
280	Large aluminum cleat	1/4	6	5/8	16	1/4 FH	6 FH	500	2.2	1000	4.5
491	Large stainless steel cleat	1/4	6	5/8	16	1/4 FH	6 FH	500	2.2	1000	4.5

WORLD WIDE LIMITED

PROFESSIONAL CUSTOMER WARRANTY

COVERAGE. HARKEN warrants the original purchaser that each HARKEN product, when properly installed, used and maintained, will be free from defects in material and workmanship under normal conditions of use, from the date of receipt of the product by the final customer. HARKEN products are covered by two different kinds of warranties, on the basis of the purchaser and use made of them.

The Private Customer Warranty

The Professional Customer Warranty

THE LIMITED PRIVATE CUSTOMER WARRANTY. This limited warranty applies to all Harken products purchased for final use by private individuals only and not for commercial or professional purposes. The Owner's sole and exclusive remedy under this limited **PRIVATE CUSTOMER WARRANTY** for original defects in materials or workmanship of a HARKEN product shall be the repair or replacement, at HARKEN's sole discretion, of the defective part or component, with no charge for the owner of the product.

THE LIMITED PROFESSIONAL CUSTOMER WARRANTY. This limited warranty applies to all Harken products purchased for final use by or on behalf of any entity (such as by corporations, partnerships, etc.) or private customers using the product for professional or commercial purposes and is expressly in lieu of all other condition and warranties, express or implied, and all other obligations whatsoever of Harken whether in contract or in tort or otherwise, for any defect, deficiency, failure, malfunctioning of any Harken product, including any part thereof except as expressly provided in this Warranty.

The Owner's sole and exclusive remedy under this limited **PROFESSIONAL CUSTOMER WARRANTY** for original defects in materials or workmanship of a Harken product shall be the repair or replacement, at Harken sole discretion, of the defective part or component, in accordance with the terms of this warranty.

WARRANTOR. For products originally sold in the United States, the limited warranty for products is provided by Harken, Inc. For products originally sold in the rest of the world, the limited warranty for the products is provided by the Harken Industrial dealer who sold the product. See procedure below. Harken Industrial is a division of Harken Inc.

OWNER – NON-TRANSFERABLE WARRANTY. This warranty is provided by Harken with only the original purchaser of the product only and does not extend to any third party. The rights of the original purchaser under this warranty may not be assigned or otherwise transferred to any third party.

WARRANTY TERM. The limited **PRIVATE CUSTOMER WARRANTY** covers any original defects in material or workmanship manifested within five (5) years of the date of receipt of the product by the final customer. However, the warranty terms under the limited **PRIVATE CUSTOMER WARRANTY** for the following products are as indicated below by the date of receipt of the product by the final customer:

1. Jib Reefing and Furling systems are warranted for seven (7) years. Hydraulic and Electric Furling systems are warranted for five (5) years. Electric furling motor, switches, control boxes, and breakers are warranted for two (2) years.
2. Reflex furler for asymmetric and code zero sails, associated adapters, cable terminals/clamps, and fairlead kits, are warranted for three (3) years. Reflex torsion cable is warranted for one (1) year.
3. Carbo Racing Foils are warranted for three (3) years.
4. Winches and handles, cylinders, valves, pumps, reservoirs, control panels are warranted for three (3) years. Electric/hydraulic winch motors, captive reel winches, hydraulic power units, switches, control boxes, and breakers are warranted for two (2) years.
5. Custom products, pedestals, gearboxes, push buttons, drive shafts, carbon fiber products, and/or high performance applications of standard catalog products for extraordinary use applications are warranted for two (2) years.
6. Ropeye® products: contact Ropeye.com for warranty terms.
7. Spinlock® products: contact Spinlock.com for warranty terms.
8. Battery for PowerSeat is warranted for two (2) years if properly used as per the indications mentioned in the manual
9. 27mm Access Rail, Marine Applications is warranted for twelve (12) months
10. 27mm Access Rail, Non-Marine Built Environment

Applications is warranted for ten (10) years

11. 32 mm Access Rail is warranted for ten (10) years

12. Tight Radius is warranted for twelve (12) months

The limited **PROFESSIONAL CUSTOMER WARRANTY** covers any original defects in material or workmanship manifested within 12 months from the date of receipt of the product by the professional customer. The same coverage for Access and Tight Radius rail and trolley in non-marine applications such constructions has a longer term of 10 years. The same coverage for Access and Tight Radius rail and trolley in marine use and corrosive applications is limited to the aforementioned 12 months term.

NOT COVERED. Neither the limited **PRIVATE CUSTOMER WARRANTY** nor the limited **PROFESSIONAL CUSTOMER WARRANTY** does not apply to, nor shall Harken have any liability or responsibility for, damages or expenses relating to defects caused by misuse, abuse, failure to install, use, maintain or store the Harken product as specified in the warranty booklet, service booklet, manuals, catalogue or other literature available from Harken.

Neither the limited **PRIVATE CUSTOMER WARRANTY** nor the limited **PROFESSIONAL CUSTOMER WARRANTY** applies to, and neither HARKEN shall have any liability or responsibility in respect of, damages or expenses relating to:

- defects in material or workmanship that did not exist when the product was first delivered;
 - defects in material or workmanship that become manifested beyond the warranty period;
 - defects which are not reported to Harken within sixty (60) days of discovery;
 - a product that has been altered or modified from factory specifications;
 - damage or deterioration of cosmetic surface finishes, including cracking, crazing, discoloration or fading;
 - accidents, misuse, abuse, abnormal use, improper use, lack of reasonable or proper maintenance or storage;
 - installation, wiring, service or repairs improperly performed or replacement parts or accessories not conforming to Harken's specifications;
 - use exceeding the recommended and permitted limits or loads of the product and/or the product on which the product is installed;
 - normal wear or deterioration occasioned by the use of the product or its exposure to the elements;
 - ropes, lines, LOUPS™, buckles and webbing;
 - clear coat finishes on carbon fiber;
 - loss of time, loss of use, inconvenience, travel expense, costs related to procuring any substitute product, transportation costs, any incidental or consequential damages arising out of the non-use of the product, or compensation for inconvenience or loss of use while the product is being repaired or otherwise not available, or other matters not specifically covered hereunder;
 - the costs to remove, store, disassemble or re-install the product;
 - the costs or expenses associated with transporting the product to and from HARKEN or a HARKEN dealer removal, storage and replacing of the product on which the product has been installed, even where this is necessary to carry out the warranty service.
- The limited **PROFESSIONAL CUSTOMER WARRANTY** does not cover, nor shall Harken have any liability or responsibility in respect of, damages or expenses relating to, the following products and/or components:
- pawls and pawl springs in winches;
 - components and gears in titanium;
 - washers and spacers;
 - winch drum grip;
 - ball bearings, roller bearings, thrust bearings;
 - winch handles.

PROCEDURE. In the event of a defect covered by this limited warranty, the Owner shall contact one of Harken worldwide Distributors (see www.harkenindustrial.com or www.harken.com). If the product was originally purchased in European Union the Owner shall promptly contact the dealer that sold the product. To obtain warranty service for your Harken product, your specific and detailed claim must be reported to and received by Harken, in writing, in accordance with the terms of this warranty and within the applicable warranty period. Claimant must specify name, address, phone number, original sales receipt, pictures with a description of the application of the product, and an explanation of the defect and conditions under which the product was used. The Owner is responsible for all expenses associated with transporting the product to and from Harken or a Harken dealer. If the examination of the product and the warranty claim reveals that the defect is not covered by this warranty, you will be contacted and advised of the cost of repair of your product. If you accept this estimate, the product will be repaired outside of this warranty.

DAMAGES OR OTHER COSTS. Except as expressly provided by this warranty, **HARKEN SHALL NOT BE RESPONSIBLE FOR ANY INCIDENTAL OR CONSEQUENTIAL DAMAGES OR OTHER COSTS, WHETHER THE CLAIM IS BASED IN CONTRACT, TORT OR OTHERWISE**, including but not limited to any costs, taxes, fees, levies or other expenses imposed by any location in which the product was originally sold. The foregoing statements of warranty are exclusive and in lieu of all other remedies. Some jurisdictions do not allow the exclusion or limitation of incidental or consequential damages, so this limitation or exclusion may not apply to you.

DISCLAIMER. ANY IMPLIED WARRANTY OF MERCHANTABILITY OR FITNESS FOR A PARTICULAR PURPOSE AND ALL IMPLIED WARRANTIES ARISING FROM A COURSE OF DEALING, USAGE OF TRADE, BY STATUTE OR OTHERWISE, IS HEREBY STRICTLY LIMITED TO THE TERM OF THIS WRITTEN LIMITED WARRANTY. This Agreement is complete and shall be the sole and exclusive remedy available to the Owner with respect to this product. In the event of any alleged breach of any warranty or any legal action brought by the purchaser based on alleged negligence or other tortious conduct by Harken, the Owner's sole and exclusive remedy will be repair or replacement of defective materials as stated above. No dealer and no other agent of Harken is

authorized to modify, extend or enlarge this warranty that may be extended, altered or varied by written instrument by Harken only.

APPLICABLE LAW. This warranty is governed by the laws of the State of Wisconsin for all products originally sold outside the European Union. For the products sold within the European Union this warranty is governed by the laws of the Member State where the product was originally sold. The exclusive jurisdiction and venue for any court action commenced by you under or relating to this limited warranty or any implied warranty(ies) shall be decided in the Courts of Waukesha County, Wisconsin or in the competent European Union State Member Court if the product was originally sold in European Union. Owner is informed that in the event Harken prevails in any court action, the claimant shall reimburse Harken for the expenses, including attorney fees and expenses of litigation, reasonably incurred by Harken in defending against such claim.

OTHER RIGHTS. Claimant's acceptance of delivery of the warranted Harken product constitutes acceptance of the terms of this limited warranty. This warranty gives specific legal rights, and the claimant may also have other rights under the laws of the jurisdiction involved.

ENTIRE AGREEMENT. This document contains the entire warranty given by Harken in respect of your product and supersedes any and all oral or express warranties, statements or undertakings that may previously have been made. Any and all warranties not contained in this warranty are specifically excluded. There are no terms, promises, conditions or warranties regarding your product other than those contained herein. Harken specifically does not authorize any person to extend the time or scope of this warranty or to create or assume for Harken any other obligation or liability with respect to Harken Industrial products.

GENERAL WARNINGS & INSTRUCTIONS

Industrial products make work easier and can save valuable time. However, there are inherent risks in using industrial products and related equipment that must be respected in order to avoid an accident, damage to property, personal injury, or death.

WARNINGS AND INSTRUCTIONS: You must carefully read, understand, and follow all warnings and instructions provided by Harken Industrial in order to avoid an accident. These warnings and instructions are found on the equipment, in packaging, in our brochures, on our website, or through our customer service department.

TRAINING AND EXPERIENCE: Even though Harken Industrial equipment appears simple and easy to operate (as intended by our design), our equipment should never be used unless you have a sufficient level of training and experience with load handling, or general experience in industries such as work at height, rescue, or fall restraint, and with the equipment in particular. The amount of training and experience depends on a number of factors: associated equipment, regulations, the weather conditions, and the task you are trying to complete. If you have any doubt about your training or experience, do not use the equipment. Please contact Harken Industrial or seek additional training.

AVOID ACCIDENT OR INJURY: Regardless of your skill level, in order to avoid an accident, damage to property, personal injury, or death:

1. Loads on equipment can be significant, and shock loading can quickly multiply that load to extremely high levels. All persons selecting, installing, using, or maintaining Harken Industrial equipment and related fastenings must be aware and cautious of such loads.
2. Select appropriate Harken Industrial equipment by careful analysis of published loading and relevant loading factors. Consult with a structural engineer to confirm your choice. Always follow current regulations for your industry, and use formal risk assessment for your project. See Safer Working Practice at www.harkenindustrial.com. If you prefer, contact Harken Industrial directly.

3. Never, under any circumstances, exceed the capacity or Maximum Working Load (MWL) of any piece of equipment. The maximum working load may be found in our catalog, on our website, or through our Technical Service department. Loads above the MWL can cause the equipment to suddenly fail unexpectedly.
4. Harken equipment is used in a wide variety of applications including a line of products dedicated solely to the sport of sailing. The sport of sailing has very different loading requirements compared to industrial applications. Equipment is shown and described in a separate sailing related catalog and website. Always use the industrial catalog and website for specifications and correct safety factors for non-sailing applications. Contact Harken Industrial if you have any questions about this distinction.
5. Do not use Harken equipment for human suspension unless product is specifically certified and labeled for such use. Consult Harken Industrial technical service if you have any questions regarding suitability for human suspension.
6. Make certain that all related fasteners, connections, tethers, and anchorage points follow industry regulations and match or exceed maximum working loads of Harken Industrial equipment.
7. Keep fingers, hands, hair, loose clothing, gloves, and tools away from moving parts.
8. Before manipulating any piece of equipment, be sure that all persons and objects are clear of moving components.
9. Always follow a regular and formal procedure for inspecting and replacing equipment and related fastenings. Document all inspections. Follow instructions in the product manual for "removing from service after shock loading."
10. Follow maintenance procedures specified in the manual to keep your equipment in optimum working order.
11. Be sure all products and related safety equipment and electronics are in good working order before using.
12. Always have a rescue plan in place and the means to implement it for operators working in human suspension or working at height. Communicate that plan to users, authorized personnel, and rescuers.

REGIONAL SALES AND OPERATIONS

USA

Harken USA - Corporate Headquarters
Pewaukee, Wisconsin
+1 262 691 3320
infoUSA@harkenindustrial.com

ITALY

Harken Italy S.p.A
Limido Comasco (CO), Italy
+39 031 3523511
industrial@harken.it

UK

Harken UK Ltd.
Lymington, Hampshire
+44 01590 689122
info@harkenindustrial.com

HARKEN INDUSTRIAL-OWNED DISTRIBUTORS

AUSTRALIA

Harken Australia Pty, Ltd.
+61 2 8978 8666
info@harken.com.au

POLAND

Harken Polska Sp. z o.o.
+48 22 561 93 93
polska@harken.pl

FRANCE

Harken France
+33 5 46 44 51 20
pierre@harken.fr

SWEDEN

Harken Sweden AB
+46 8 222200
harken@harken.se

NEW ZEALAND

Harken New Zealand Ltd
+69 9 303 3744
info@harken.co.nz

HARKEN INDUSTRIAL-OWNED TRAINING RESOURCES

ELEVATED SAFETY

4044 N Lincoln Ave, Suite 301
Chicago, IL 60618
+1 866 819 2194
info@elevatedsafety.com

For an up-to-date listing of independent Harken Industrial Distributors, Dealers and Certified Installers, please visit harkenindustrial.com.



ON THE COVER

Harken Industrial and Elevated Safety employees working along side our teammates from Defiant Marine, were in the first wave of responders contributing to the successful rescue of four merchant sailors from the 656-foot freighter Golden Ray which foundered off Brunswick, Georgia on September 8, 2019.