

PI-2 PHONE INTERCOM SYSTEM

INSTALLATION / OPERATION MANUAL

U.S.A.:

2911 West Garry Avenue, Santa Ana, CA 92704
Phone: (714) 751-0488 Fax: (714) 957-1621

EURO:

Unit 7 Bessemer Park, 250 Milkwood Rd., London SE 24 OHG UK
Phone: +44-71-738-4466 Fax: +44-71-738-6606

PI-2

PHONE INTERCOM SYSTEM

INSTALLATION / OPERATION

It is recommended that you read these instructions completely prior to acquiring tools and materials for the installation of the Phone-Com in order to help you decide which tools and materials are appropriate for your particular installation.

Recommended Tools:

Phillips screwdriver, slotted screwdriver, wire cutter, wire stripper, wire crimper.

Recommended Materials:

Four #8 mounting screws*, ten #6 lug connectors*, color-coded multi-conductor cable* (22 AWG minimum, four or five conductors depending on application - see Wiring Diagrams section), cable ties, in-line fuse assembly*, wire splices.

Note: These () items are provided with model PI-2 SET.*

Mounting:

1) Select a suitable location for mounting each Phone-Com. Any conveniently located vertical or horizontal flat surface will suffice - wood, metal or fiberglass. You may leave the phone unmounted on a tabletop, but fixed mounting will decrease the chance of eventual strain on the wiring which may cause loose connections. The Phone-Com is not waterproof and should not be located where it will be exposed to spray or excessive moisture. Avoid mounting the Phone-Com near fluorescent lights as these may interfere with its operation.

2) Remove the mounting bracket from the base of the Phone-Com by sliding it downward until it releases. Using two each #8 mounting screws, securely attach the bracket to the mounting surface with the "L" shaped securing tabs facing outward and upward.

Wiring:

1) Wiring the Phone-Com will probably be made easiest by securing it first to the mounting bracket. Align the slots on the back of the base with the mounting bracket securing tabs and slide downward. The Phone-Com will lock into place.

2) Disconnect the phone plug which attaches the handset to the base. Set the handset aside for the time being.

3) Using a phillips screwdriver, remove the copper-colored screw which is on the front of the base where the mouthpiece normally rests. Remove the base cover by pulling outward slightly at the bottom and pushing it upward to release it. Note the terminal block in the center of the base with five terminals labeled "+", "CH", "B", "-", and "1", respectively.

4) Repeat all of the above steps for the second Phone-Com.

5) Route your four or five conductor cable between the two Phone-Com calling stations and then cut it to the appropriate length. (See Wiring Diagrams to determine whether you need four or five conductors.) Note that the cable is routed into the Phone-Com via a small port located beside the phone jack at the bottom of the base. Color coded wiring is recommended to insure that wires are connected to proper terminals.

Five conductor cable is available from NEWMAR. Request part number 110-2205-0.

The cable should not be routed alongside unshielded cables or other electronic or electrical devices which may radiate electrical noise into the Phone-Com wiring. Such noise sources may include tachometer wiring, VHF power leads, battery charger leads, alternator charging leads, etc. Non-metallic fasteners such as cable ties are recommended for securing the cable. If metal fasteners such as staples are used, ensure that the cable is not accidentally pierced or shorting of the conductors may occur.

6) Strip the ends of the individual conductors of the multi-conductor cable and your "+" and "-" power leads. Terminating the leads with ring lug connectors will ensure a secure installation. If you choose to terminate the leads use ring terminals appropriate for a #6 screw. Note that some terminals will need to accommodate two conductors. Where this is the case both conductor leads must be crimped into the same lug.

7) Attach the conductors to the terminal strip of each Phone-Com according to the appropriate diagram on the following page, carefully noting the color of each conductor to ensure correct connections. The wiring scheme in diagram A may be used on vehicles with positive, negative or floating grounds. The scheme in diagram B may only be used on negative ground vehicles. Both methods will yield identical performance of the Phone-Com.

8) Replace the base cover and reattach the handset.

Wiring Diagrams (Two Stations Only):

5 CONDUCTOR METHOD

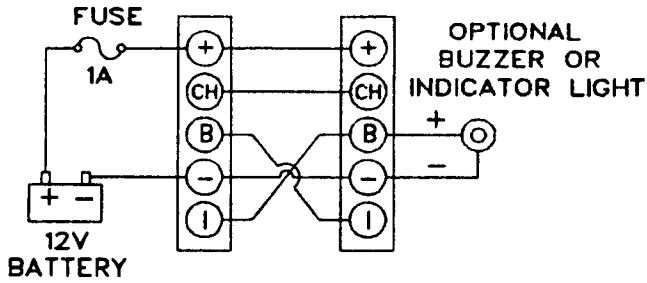

Diagram A

**4 CONDUCTOR METHOD
(I.E. NEGATIVE GROUND VEHICLE)**

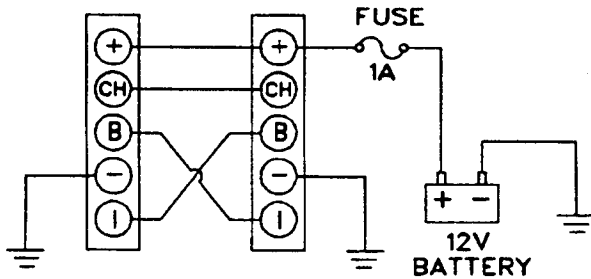

Diagram B

Operation:

Energize your 12 volt power source. Operation is then simply a matter of picking up the handset and pressing the button on the Phone-Com base. The buzzer on the other station will sound and the red light below the button will illuminate for as long as you are pressing the button.

If you wish to operate the Phone-Com in a high noise area where the internal buzzer may not be heard, a separate 12 volt buzzer or indicator lamp which may be mounted externally in a more conspicuous or convenient location is available from NEWMAR. Check with your electronics dealer or contact the factory. (Buzzer part number: 117-0100-0, Indicator Lamp part number: 578-0028-0.)

Slave Option:

If you desire, you may hook up an additional Phone-Com as a "slave" to another unit. This involves wiring the second unit in parallel with the first. (i.e., connect "B" of the first unit to "B" of the second, "CH" of the first unit to "CH" of the second and so on). When wired this way the slave phone will behave exactly as the phone it is in parallel with. It will be paged (buzz) at the same time and it can be used to call the other primary phone. However you will not be able to page (buzz) the parallel unit. Multiple station selective calling requires NEWMAR model PI-10. Proper wiring for an additional slave station is illustrated below.

Wiring with Slave Station:

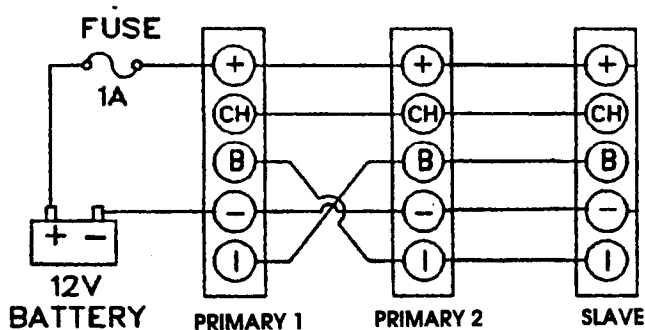

Troubleshooting:

PROBLEM	POSSIBLE CAUSE	SOLUTION
A. Intercoms will not communicate or page each other.	1. Input power circuit breaker is tripped or fuse in power lead is blown.	1. Reset circuit breaker or replace after determining cause of overload.
	2. Bad 12 volt connection to intercom.	2. Using a voltmeter, verify that intercoms are receiving 12 volts across terminals "+" and "-". If not locate bad connection in wiring.
	3. Mis-wire of terminals "B", "CH" and "1".	3. Verify proper wiring - refer to wiring diagram.

PROBLEM

POSSIBLE CAUSE

SOLUTION

B. Intercoms communicate, however one or both cannot be paged.

- 1. Terminals "B" and "1" are incorrectly wired.
- 2. Bad connection on terminals "B" or "1" or defective intercom.

- 1. Verify proper wiring - refer to wiring diagram.
- 2. To verify bad connection, attach voltmeter between terminals "-" and "B" of silent intercom. Voltmeter should indicate at least 12 volts when intercom is being paged. If so, then intercom is defective. If not, move voltmeter to terminals "-" and "1" of paging intercom and push its paging button. If 12 volts is measured, locate bad connection between "1" of paging intercom and "B" of silent intercom. If 12 volts is not measured, paging intercom is defective.

C. Intercoms function properly, however communication is weak, hard to hear.

12 volt source low.

If battery powered recharge battery. If powered by AC to DC converter, measure output voltage. If low (less than 12 VDC) repair or replace converter.

PROBLEM	POSSIBLE CAUSE	SOLUTION
D. Noise on intercom when engine is running or battery charger is operating.	Engine alternator, ignition system or battery charger putting AC ripple into 12 volt battery system powering intercoms.	Install filters on alternator/ignition system, battery charger and/or 12 volt input power leads to intercom. Contact factory for additional help.
E. Noise on intercom when engine and battery charger are turned off.	Defective handset.	Replace handset - contact factory.

Specifications:

Input Range: 12-15 VDC
Maximum Distance Between Stations: 1600 feet
Operating Current (Talking): 20 milliamps
Operating Current (Buzzing): 45 milliamps
Wire Gauge: 22 AWG minimum
Size 8½"H x 3 ¾"W x 3"D
Weight: 1.1 lbs.

NEWMAR LIMITED WARRANTY

Newmar warrants the original purchaser of this PI-2 Phone Intercom System that it shall be free from defects in material and workmanship for a period of six (6) months from the date of original purchase.

In the event of failure caused by a defect in material or workmanship, return to place of purchase or to USA or EURO address. Please include proof of purchase, date of purchase, and a written explanation of the alleged defect. If this product is determined to be defective by Newmar, Newmar will repair the product without charge. Any repairs or adjustments to be made on a defective product shall be determined by Newmar.

This warranty does not apply to products that have not been properly installed nor to products that have been damaged through accident, negligence, misuse, alteration, abuse, or normal wear and tear. For proper installation either have the authorized Newmar dealer install the product or an electronic technician of your choice may install the product, by carefully following the directions provided at the time of purchase.

Newmar limits its liability under this warranty to the repair of the product or reimbursement of the cost of the product to the consumer. This warranty does not cover postal and freight charges to return the product for repair.

For your own protection, check the product upon receipt for any damage during shipping. Any such damage should be referred to the carrier.

No person, including any Newmar dealer is authorized to assume any further liability on behalf of Newmar beyond the warranty. Any purchaser should be referred exclusively to this warranty.

Newmar reserves the right to make changes in design and improvements on its products without assuming any obligations to install these improvements or otherwise modify any previously manufactured product.

There are no other warranties either express or implied that shall exist beyond the terms of this warranty.

Some states do not allow the exclusion or limitation of incidental or consequential damages, so the above limitation or exclusion may not apply to you.

This warranty gives you specific legal rights, and you may also have other rights which vary from state to state.

PART # M-PI-2-A