

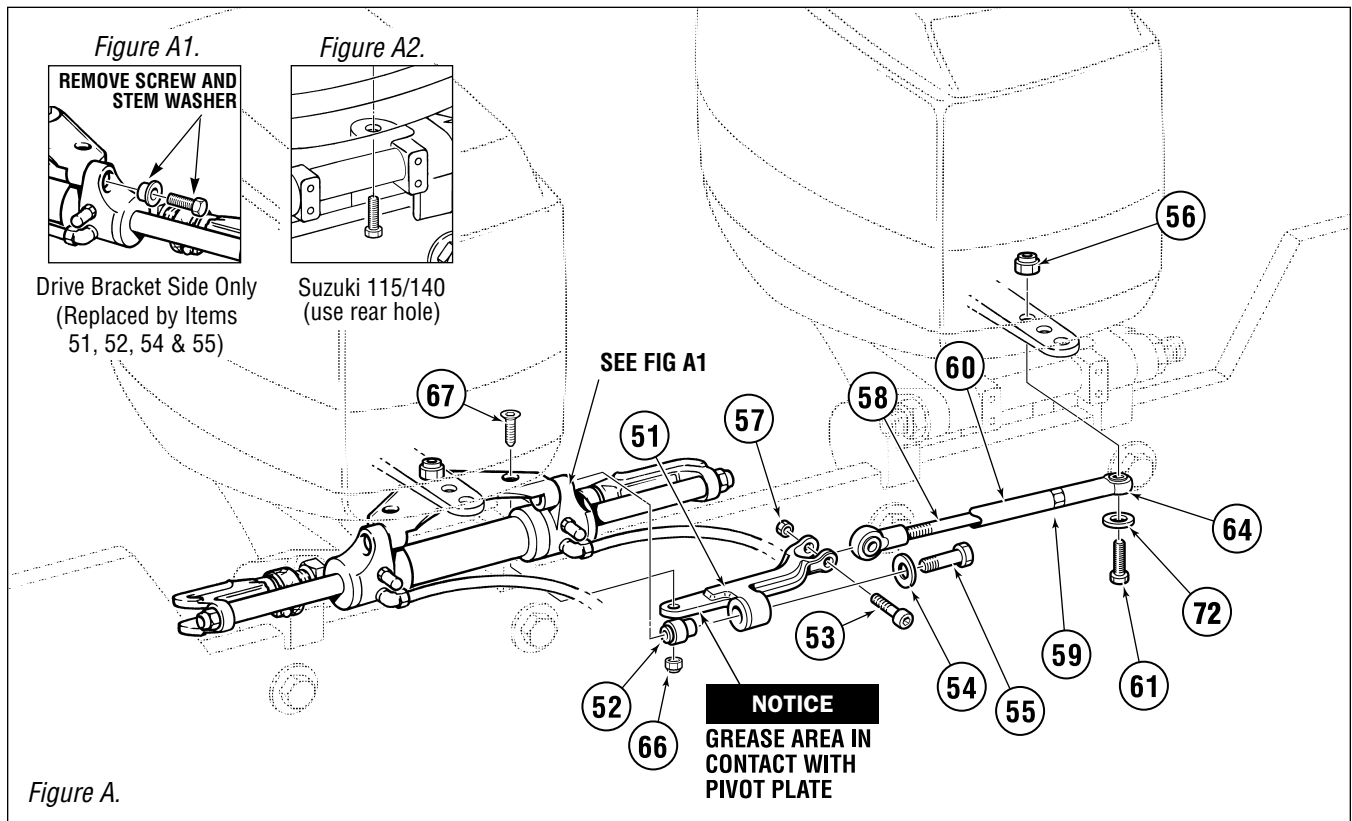

TIE BAR KIT # H06003

Single Cylinder Johnson/Evinrude, Suzuki

ENGINE MANUFACTURER	YEAR	MODEL	CYLINDER	ENGINE TIE BAR KITS		NOTE
				SINGLE CYLINDER	DUAL CYLINDER	
JOHNSON/EVINRUDE	1997-TO DATE	70-175 HP	HC5345	H06001	H06002	Min. Engine Centers 29"
	1991-TO DATE	250-300 HP	HC5345	H06001	H06002	
	1996-TO DATE	90-225 HP FICHT	HC5345	H06003	H06002	
	1991-TO DATE	200-225 HP	HC5345	H06003	H06002	
	1998-TO DATE	65-70 HP 4-Stroke	HC5345	H06003	H06002	
SUZUKI	1986-TO DATE	115-225 HP	HC5345	H06003	H06002	See Fig. A2



ITEM	PART #	QTY	DESCRIPTION
51	961665	1	Drive Bracket Assembly
52	961686	1	Spacer
53	186540	1	Shoulder Bolt, 3/8" x 1-1/4", SS
54	010924	1	Washer 5/16" Flat 3/4", SS
55	961704	1	HHCS 5/16" NC x 2", SS
56	113529	1	Nut, Nylok®, 3/8" NF, SS
57	704525	1	Nut, Nylok®, 5/16" NC, SS
58	722545	1	Tie Bar c/w Ball Joint (H06003)

ITEM	PART #	QTY	DESCRIPTION
59	192126	1	Nut, Nylok® 1/2" NF, NI PL BR
60	722755	1	Stringer Tube
61	116320	1	HHCS, 3/8" NF x 1-1/2", SS
64	116527	1	Rod End SS 1/2" NF
66	113021	1	Nut, Nylok®, 5/16" NC, SS, Thin
67	185901	1	FHSCS, 5/16" NC x 3/4", SS
72	113622	1	Washer, 3/8" Dia., SS