

OWNER'S MANUAL

CABO™

Adventurer Series™ Electric Grill
A10-703E



For questions regarding performance, assembly, operation, parts, or returns, contact the experts at MAGMA by calling **(562) 627-0500** 7:00 a.m. - 5:00 p.m. Pacific Time Monday thru Friday or e-mail us at mail@MagmaProducts.com

MAGMA®

U S A

IMPORTANT, read these instructions carefully before use. Familiarize yourself with the appliance before connecting it to its gas container. Keep these instructions for future reference.

IMPORTANT SAFETY WARNINGS

READ ALL INSTRUCTIONS BEFORE OPERATING.



WARNING!
POTENTIAL SHOCK
HAZARD

This appliance is Rated for
120 volts - 60Hz, 12.5 Amps Output: 1500W.
Use only Magma part number 10-142 Marinized Electric Cord with temperature control.



This grill is intended for outdoor household use only.
Do not use indoors or for commercial cooking. Fuels such
as charcoal briquettes, are not to be used with appliance.



The supply cord should be regularly examined
for signs of damage and the appliance is not to
be used if the cord is damaged.

DANGER

Failure to follow the Dangers, Warnings and Cautions contained in this Owner's Manual may result in serious bodily injury or death, or in a fire or an explosion causing damage to property.

IMPORTANT SAFEGUARDS

When using electrical appliances, basic safety precautions should always be followed including the following:

1. Read all instructions
2. Do not touch hot surfaces. Use handles or knobs.
3. To protect against electrical shock do not immerse cord, plugs, the heating element and the appliance in water or other liquid.
4. Close supervision is necessary when any appliance is used by or near children.
5. Unplug from outlet when not in use and before cleaning. Allow to cool before putting on or taking off parts.
6. Do not operate any appliance with a damaged cord or plug or after the appliance malfunctions or has been damaged in any manner. Contact Magma for the nearest authorized service facility for examination, repair, or adjustment.
7. The use of accessory attachments not recommended by the appliance manufacturer may cause injuries.
8. Do not let cord hang over edge of table or counter, or touch hot surfaces.
9. Do not place on or near a hot gas or electric burner, or in a heated oven.
10. Extreme caution must be used when moving an appliance containing hot oil or other hot liquids.
11. Always attach plug to appliance first, then plug cord into the wall outlet. To disconnect, turn any control to off, then remove plug from wall outlet.
12. Do not use appliance for other than intended use.
13. Fuel, such as charcoal briquettes, is not to be used with appliance.
14. To ensure continued protection against risk of electric shock, connect to properly grounded outlets only.
15. Use only outdoors, do not expose to rain.
16. To prevent electric shock, unplug (pull out the plug from the outlet) before cleaning and disassembly the heating element.
17. a) A short power-supply cord (or detachable power-supply cord) should be used to reduce the risk resulting from becoming entangled in or tripping over a longer cord.
b) Longer detachable power-supply cords or extension cords are available and may be used if care is exercised in their use.
c) If a longer detachable power-supply cord or extension cord is used:
 - 1) The marked electrical rating of the cord set or extension cord should be at least as great as the electrical rating of the appliance; and
 - 2) The cord should be arranged so that it will not drape over the countertop or tabletop where it can be pulled on by children or tripped over unintentionally.
 - 3) The extension cord should be a grounding-type 3-wire cord.
- d) Outdoor extension cords should be used with outdoor use products and are surface marked with the suffix letter "W" and with a tag stating: "Suitable for use with outdoor appliances".
- e) Risk of Electric Shock. Keep extension cord connection dry and off the ground
18. Store products (including heat element and temperature-control cord) indoors when not in use - out of the reach of children.
19. Do not clean this product with a water spray or the like, unless the heat element and the temperature-control cord all are removed.
20. Use only with the temperature-control cord - Manufacturer: Kosway Electrical Ltd, type A10-703E. Magma Part No. 10-142.
21. Use only with the Heater element - type 703E. Magma Part No. 10-141.
22. Do not crush or fold the heater.

SAVE THESE INSTRUCTIONS

MOUNT HARDWARE

Fasteners are supplied for Single Mount grill mounting options.
See Magma Website for mount selection: MagmaProducts.com

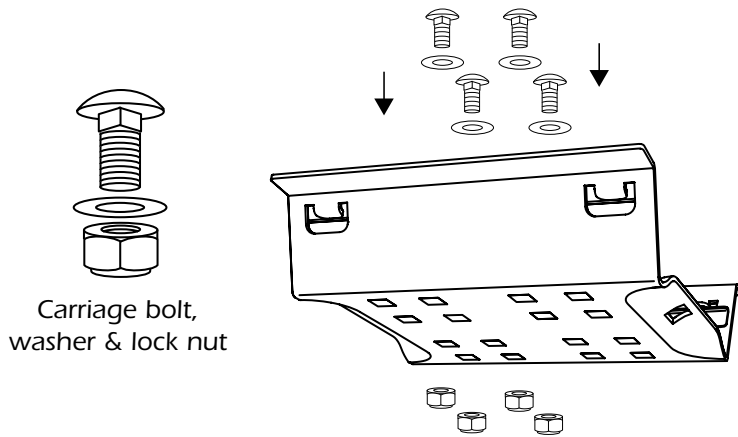

Single mount through-bolt applications

4 Carriage bolts,
washers & lock nuts.

Note: Place washers on
carriage bolts as shown.

See Magma website for replacement part numbers.
MagmaProducts.com

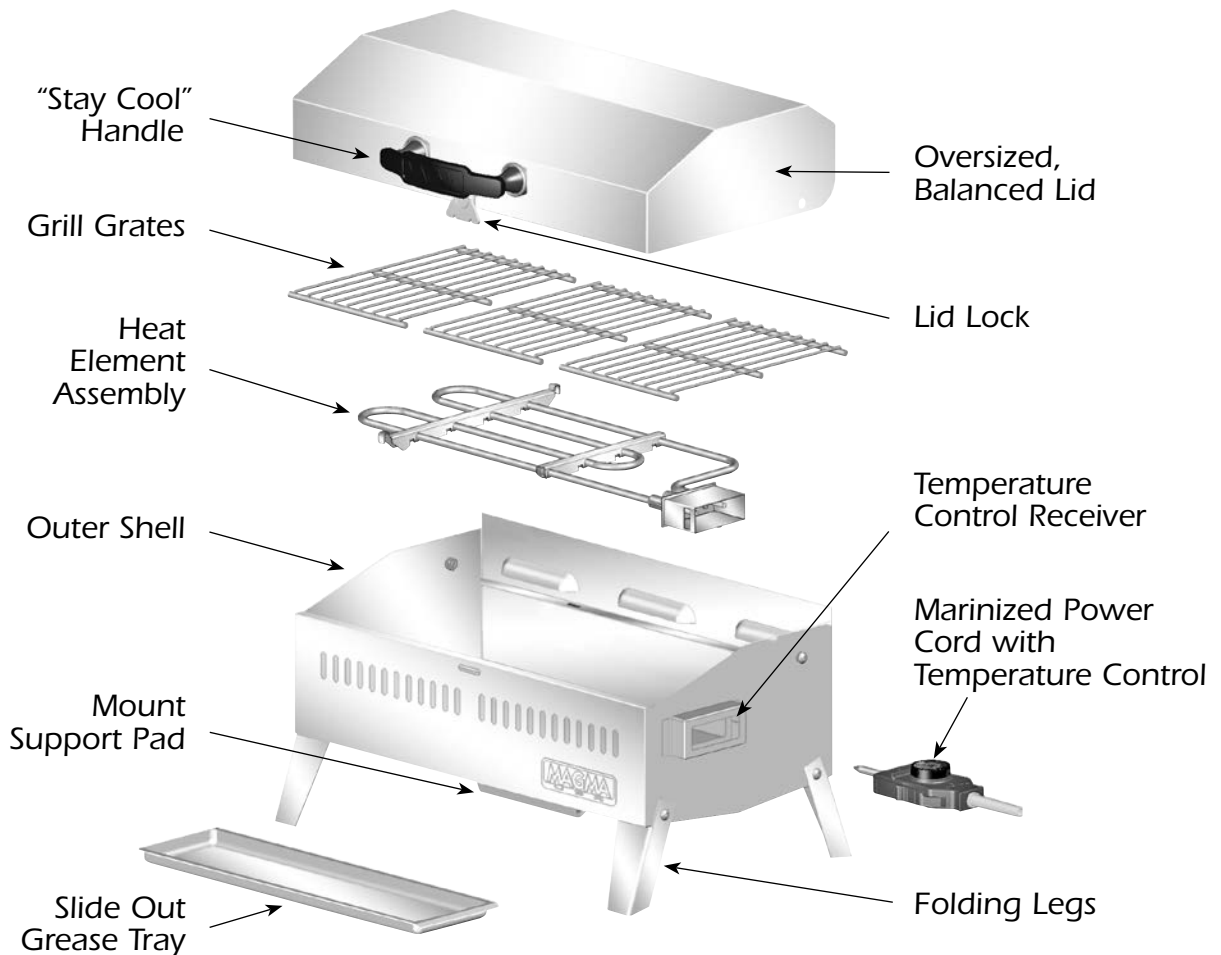

OPERATING PROCEDURES

PRACTICAL HINTS

Before using the grill be sure that:

- Grill is secure and properly mounted
- Internal components and grease tray are clean and correctly positioned
- Lid Lock has been set not to engage by opening lid and turning lock to the locked position

Instructions:

- Open Lid.
- Plug Power Cord into Temperature Control Receiver.
- Insure Temperature Control is in "OFF" position
- Plug Power Cord into GFI outlet



(a) Grounding Instructions

This appliance shall be grounded while in use to protect the operator from electrical shock. The appliance is equipped with a 3-conductor cord and a 3-prong grounding-type plug to fit the proper grounding-type receptacle. Plug into a GFCI-protected outdoor receptacle, where available.



(b) Extension Cords

Use only 3-wire extension cords that have 3-prong grounding-type plugs and 3-pole cord connectors that accept the plug from the appliance. Only extension cords identified by the marking "Suitable for use with outdoor appliances" shall be used outdoors. Use only extension cords having an electrical rating not less than the rating of the appliance. Do not use damaged extension cords. Examine extension cord before using and replace if damaged. Do not abuse extension cord and do not tug on any cord to disconnect. Keep cord away from heat and sharp edges.

- Turn Temperature Control to "HIGH" position
- Close Lid
- Preheat Grill for 15 minutes
- Grilling with the lid closed reduces grilling times

To reduce flare up:

- Empty and clean grease tray prior to each use
- Trim excess fats from meats
- Use non-oil based marinades
- Reduce heat

Stowing Tips:

- Do not stow grill below decks
- Stow power cord in dry area with Temperature control in "OFF" position
- Empty grease tray prior to stowing grill

DISASSEMBLY & RE-ASSEMBLY

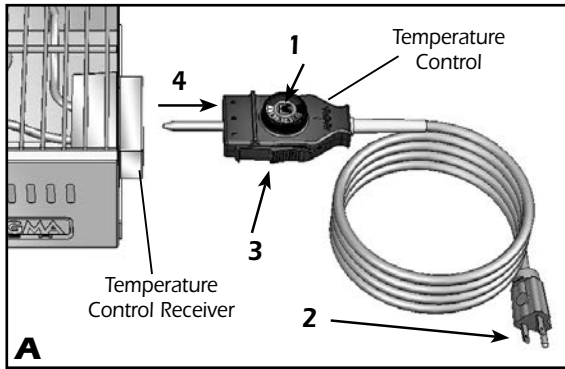

- 1.** Turn Temperature Control to OFF.
- 2.** Unplug cord from power source.
- 3.** Press in Safety Lock on the side of the Control.
- 4.** Slide Temperature Control out from its Receiver.

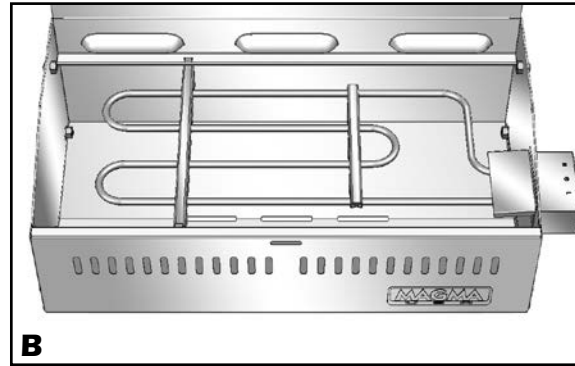

- 5.** Remove grill grates.

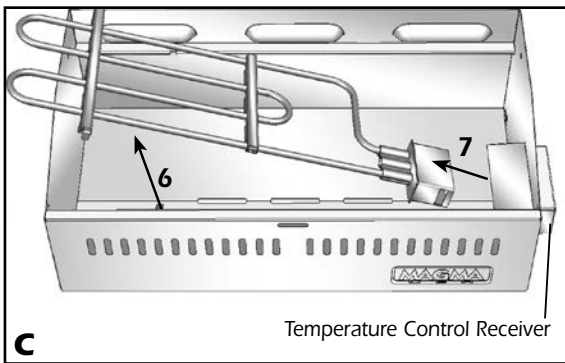

- 6.** Lift up left side of the heat element.
- 7.** Slide out from the Receiver.

- Inspect heat element, remove any obstructions.
- Clean as indicated in Maintenance (page 6).
- To re-assemble, reverse the procedure above.

LOCKING GREASE TRAY ACCESSIBLE FROM EITHER SIDE

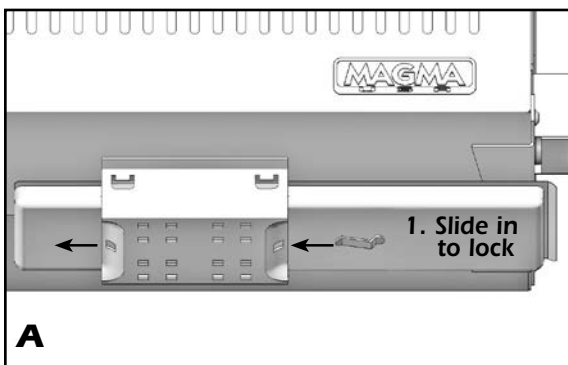

- 1.** Slide Grease Tray into either side of the mounting bracket to lock.

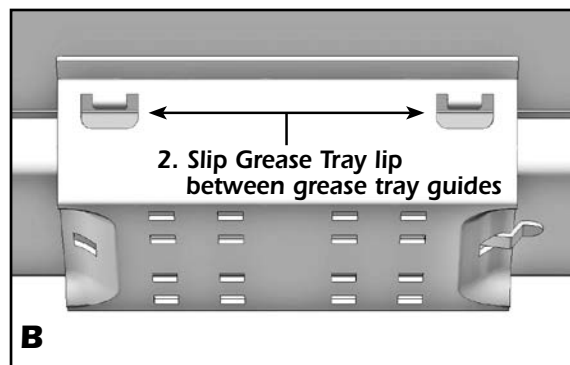

- 2.** Slip Grease Tray lip between both grease tray guides.

MAINTENANCE

Stainless steel contrary to popular belief can rust. Most commonly, deposits on surface of the product will trap moisture. It is this moisture that robs stainless steel of oxygen. Oxygen is the element that reacts with stainless steel to form a protective layer of chrome oxide. Robbed of oxygen, this reaction does not take place and “crevice corrosion” or “surface rusting” occurs. To minimize this effect, thoroughly clean your grill with soap and water, rinse with fresh water, and dry. Avoid using stainless steel polishes on grill exterior as most leave a residue that may discolor when grill is heated.

Additionally, stainless steel that is exposed to high heat will change color and texture over time. The “amber” color of grill exterior and internal components is not a failure of the stainless steel and will not affect products operation. When this happens, we recommend using “**Magma Magic**” **Grill Restorer** to remove the “amber” color and return grill to its original luster. However, prolonged exposure to extreme high heat will cause chromium and nickel to “burn out” of stainless steel. At this point stainless steel will become more susceptible to corrosion and will start to deteriorate. We recommended replacement of internal components as they become seriously deteriorated.

We recommend thoroughly cleaning grill and internal components after each outing. Disassemble interior components and remove all food residue. Use a “Scotch-Brite” pad or similar product and “Easy-Off” oven cleaner for cleaning grills interior components (except Heat Element), followed by thoroughly washing with soap and water, rinse with fresh water & dry. **AVOID CONTACT OF OVEN CLEANER WITH SKIN, POWER CORD, HEAT ELEMENT, AND BOAT SURFACE. CAUTION: DO NOT USE ANY TYPE OF ABRASIVE PAD ON EXTERIOR MIRROR FINISH AS IT WILL SCRATCH SURFACE, USE ONLY A SOFT CLOTH. DO NOT IMMERSIVE POWER CORD OR HEAT ELEMENT IN WATER OR OTHER LIQUID.** We recommend covering grill between uses. Grill covers are available at Magma retailers or directly from Magma. See our website, **MagmaProducts.com**.

Grill Grates - Clean with brass wire brush while grill is warm. Use Oven & Grill cleaner for burnt-on residue. Wash with soapy water and dry prior to storage.

Heat Element - Clean with damp cloth. Do not immerse Heat Element in liquid. Do not clean with abrasive cleaners or abrasive pads.

Repair/Replacement Parts - All replacement parts are readily available at your Magma Retailers or directly from Magma.

For a complete list of replacement parts visit our website **MagmaProducts.com**.

TROUBLESHOOTING GUIDE

Problem	Possible Cause	Possible Solution
Electric Grill Will Not Turn On	Power Cord not properly engaged	<ul style="list-style-type: none"> ▪ Check that the Power Cord is fully inserted through the temperature Control Receiver and into the Heat Element ▪ Check that the Power Cord is fully inserted into GFI outlet.
	GFI outlet is tripped	<ul style="list-style-type: none"> ▪ Reset GFI
Flare-Up	Excessive cooking temperature	<ul style="list-style-type: none"> ▪ Turn temperature control to lower temperature ▪ Open lid
	Grease and/or residue build-up	<ul style="list-style-type: none"> ▪ Clean components
	Excessive fat in meats	<ul style="list-style-type: none"> ▪ Trim excess fat before grilling
	Excessive oils in marinades	<ul style="list-style-type: none"> ▪ Use non-oil based marinades

CONTENTS

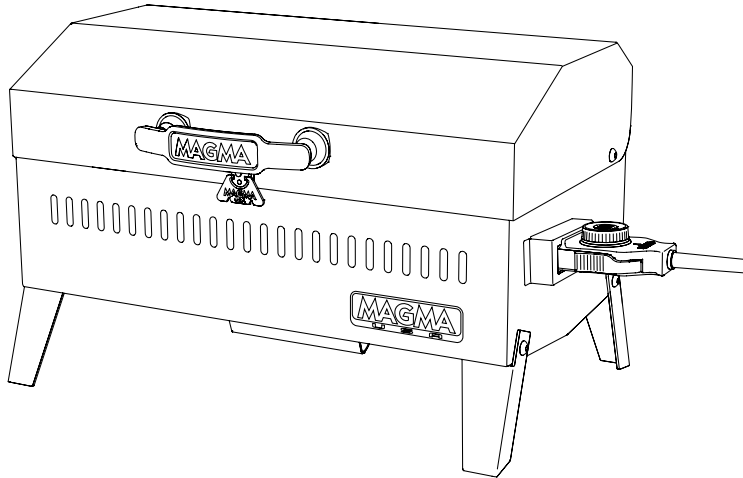

x 4

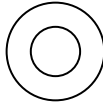

x 4



x 4

Pack of (4) 1/4"-20 x 5/8" carriage bolts and lock nuts for mounting applications.

LIMITED WARRANTY

Magma Products, Inc. guarantees this product to be free from defects in materials or workmanship to the original consumer. This guarantee is for the periods herein specified when used under normal and reasonable conditions, one (1) year from the date of original purchase. This warranty does not include the cost of property damage or any inconvenience due to the failure of the product. Nor does it cover damage due to misuse, abuse, accident, or damage resulting from transportation of the product. Nor does it include damage resulting from the commercial use of this product. Nor does it include, on stainless steel products, "Surface Rust"; Excessive Corrosion due to exposure to salt water; or Discoloration or Corrosion caused by exposure to excessive heat or failure to properly clean and care for the stainless steel surfaces. If the product fails to operate due to a defect in materials or workmanship during the warranty period, the defective part will be repaired or replaced at Magma's option. If you wish to obtain performance under this limited warranty, you should contact Magma's Customer Service Department via telephone at (562) 627-0500, or via e-mail at mail@MagmaProducts.com, or via U.S. Postal Service mail at "Magma Products, Inc., Attention Customer Service, 3940 Pixie Ave. Lakewood, CA, 90712". The defective part, along with proof of purchase, must be returned postage prepaid to Magma Products, Inc. We suggest that you keep your purchase receipt as we may require reasonable proof of purchase.

In the state of California only, if refinishing or replacement of the product is not commercially practicable, the retailer selling the product, or Magma Products, Inc., will refund the purchase price paid for the product, less the amount directly attributable to use by the original consumer prior to the discovery of the nonconformity. In addition, in the state of California only, you may take the product to the retail establishment from which it was purchased or to any retail establishment selling this product in order to obtain performance under this warranty. All implied warranties, including the implied warranties of merchantability and fitness for a particular purpose, are limited in duration to the express warranty periods specified herein for the parts described herein. Some states do not allow limitations on how long an implied warranty lasts, so the above limitation may not apply to you. Neither Magma dealers, nor the retail establishment selling this product has any authority to make any warranties or to promise remedies in addition to or inconsistent with those stated above. Magma's maximum liability shall not exceed the purchase price of the product paid by the original consumer. Some states do not allow the exclusion or limitation of incidental or consequential damages, so the above limitation or exclusions may not apply to you. The warranty gives you specific legal rights and you may also have other rights which vary from state to state.

MAGMA and the Magma logo are registered trademarks of Magma Products, Inc. ■ Cabo is a trademark of Magma Products, Inc. ■ Patent pending.

MAGMA[®]

U S A

Magma Products, Inc.
3940 Pixie Avenue, Lakewood, CA 90712 • USA
Phone (562) 627-0500 • mail@MagmaProducts.com
MagmaProducts.com