

# FLOJET

## “Quad II Diaphragm” 4325 Series Automatic Washdown Pump

### FEATURES

- Self-Priming
- Dry Running
- Soft, Noise Absorbing Mounts
- Corrosion Resistant Materials
- Models Meet U.S.C.G. Electric Standards
- Thermally Protected
- A.C. Models Have 6' Power Cord

### SPECIFICATIONS

**Motor:** Permanent Magnet, Ball Bearings at Front & Rear Endbell. CE Models are fully suppressed.

**Pump:** Four chamber positive displacement diaphragm design; Self-priming up to 10 ft. suction lift; Pump able to run dry without damage; Removable port to hose connectors.

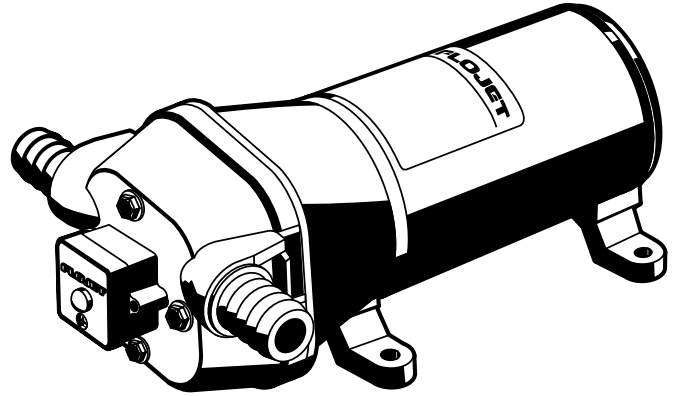

Model 4325 Series



(Available on 12 & 24V d.c. Models and 230V a.c. Model)

Pump Series	Dimensions - Inches (mm)			Weight lb. (kg)
	Height	Width	Length	
4325-XXX	3.75 (95)	6.3 (160)	9.9 (252)	6.0(2.8)

MODEL	VOLTS	AMP DRAW @ 10 psi (0.7 bar)	FLOW GPM (l/min)	PRESSURE SWITCH	STRAINER	PRESSURE
				MAX psi (bar)		NOZZLE
4325-143A	12V dc	6.0	4.5 (17)	40 (2.8)	Yes	No
4325-143L	12V dc	6.0	4.5 (17)	40 (2.8)	Yes	Yes
4325-343A	24V dc	2.5	4.5 (17)	40 (2.8)	Yes	No
4325-343L	24V dc	2.5	4.5 (17)	40 (2.8)	Yes	Yes
4325-443A	32V dc	2.0	4.5 (17)	40 (2.8)	Yes	No
4325-043A	115V ac	0.5	4.5 (17)	40 (2.8)	Yes	No
4325-243A	230V ac	0.3	4.5 (17)	40 (2.8)	Yes	No

\* CE fully suppressed models are identified by a prefix “R” and a CE mark on the label. (i.e. R4325-143L). Self Declaration Of Conformance (SDOC) is available upon request.

### OPERATION

With pump intake connected to supply tank or through hull fitting, and operation switch off, open outlet valve, then turn pump switch on. Water will begin to flow, when water is free of air turn valve off. When valve is shut off pump will stop. Should pump fail to stop, turn switch off and see the trouble shooting guide.

For portable use we recommend the pump be mounted on a base (i.e. 3/4” x 8” x 10” board or plywood), add a length of cable with alligator clips for battery connection or plug the 1 15V ac and 230V ac Models into a G.F.I. protected electrical outlet.

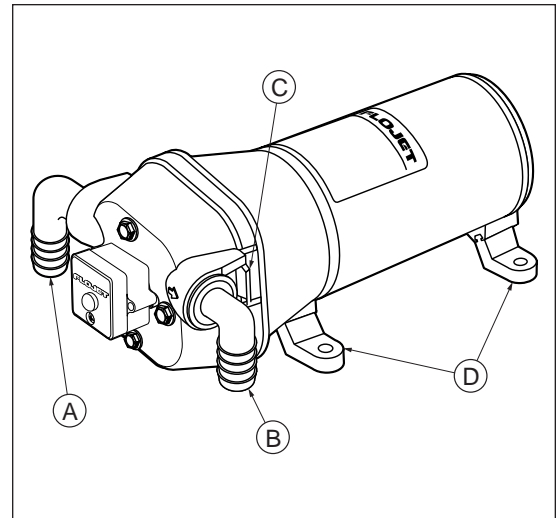
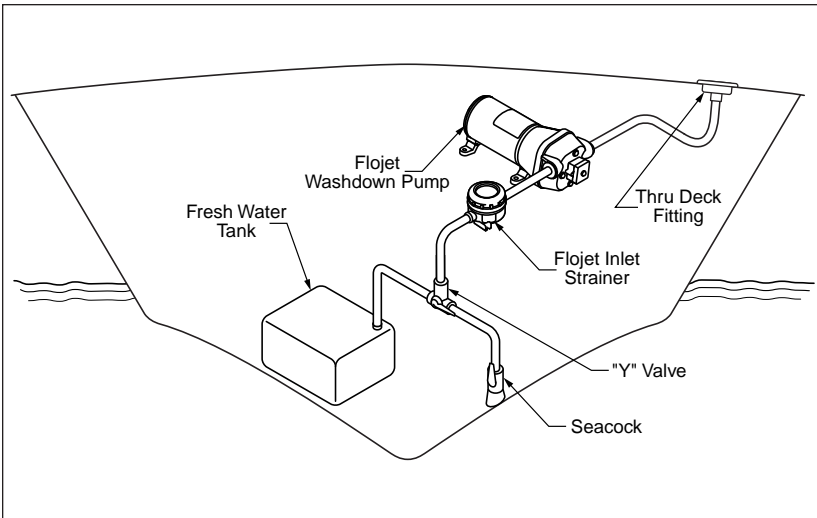

## INSTALLATION

### STEP 1

Remove shipping plugs from Quad pump ports. Some water from factory testing may spill out.

### STEP 2

Install inlet A and discharge B port connectors. Firmly push slide clips C forward to lock port connectors in place.

### STEP 3

Slide rubber mounts D fully into 4 mounting tracks.

### STEP 4

Mount pump vertically, with pump head down or horizontally in an accessible location. If mounting

vertically, motor up, attach motor mounts first, then pump head mounts while supporting weight of pump.

### STEP 5

Use 3/4" or 5/8" I.D. flexible hose (preferably braided or reinforced). Use hose clamps on the slip-on barb hose connectors.

### STEP 6

Install a 40 mesh in line strainer in accessible location between tank and pump inlet.

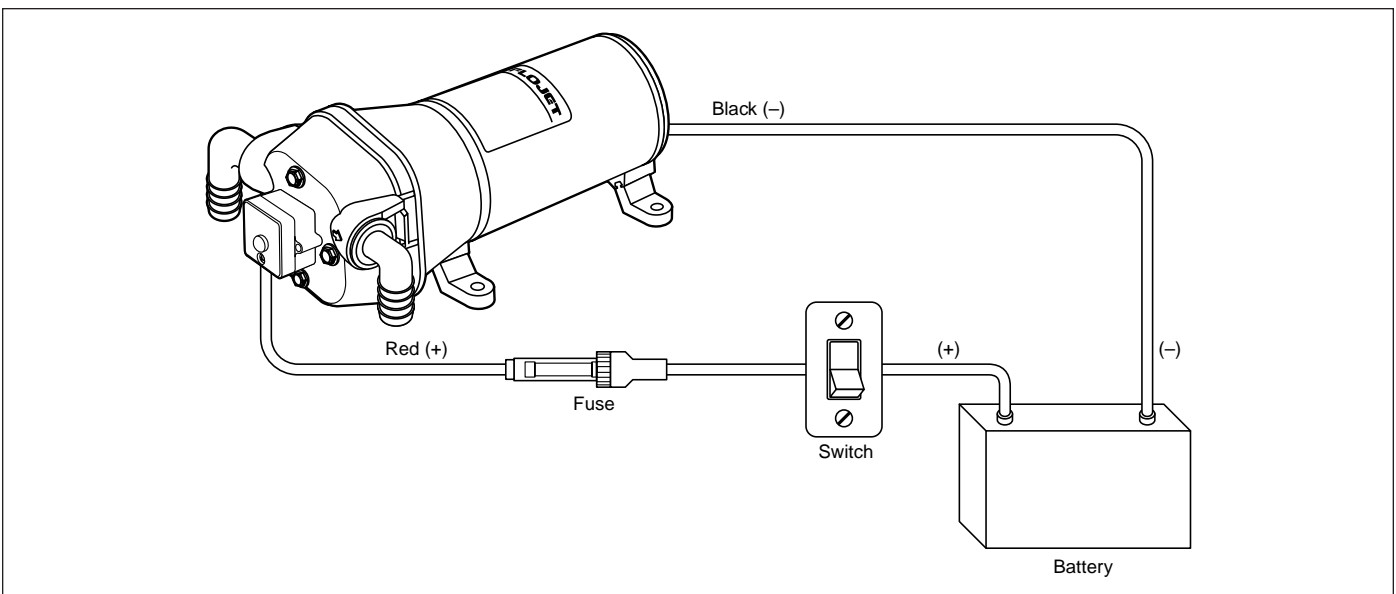

## D.C. WIRING

### STEP 1

Use 14 gauge stranded wire to 20', 12 gauge to 50', from power source.

### STEP 2

Use a 15 amp rated on-off switch on the (+) positive (red) motor lead.

### STEP 3

Install fuse protection in the positive lead. 12V use 15 amp fuse, 24V use 7 amp fuse, 32V use 5 amp fuse.

**NOTE:** The 115 Volt model may be plugged directly into a 115V a.c. electrical outlet. A G.F.I. (ground fault interruption) outlet and switched circuit is required near water.

## TROUBLESHOOTING

**WARNING: BEFORE SERVICING PUMP, TURN OFF PUMP AND DRAIN WATER FROM SYSTEM!!**

### Failure to Prime - Motor operates, but no pump discharge

- Restricted intake or discharge line
- Air leak in intake line
- Debris in pump
- Punctured pump diaphragm (pump leaks)
- Crack in pump housing

### Motor fails to turn on

- Loose wiring connection
- Pump circuit has no power
- Blown fuse
- Pressure switch failure
- Defective motor
- Open thermal protector

### Pulsating Flow - Pump cycles on and off

- Restricted pump delivery. Check discharge lines, fittings and valves for clogging or undersizing.

### Pump Falls to Turn Off After All Fixtures Are Closed

- Empty water tank
- Insufficient voltage to pump (low battery)
- Punctured pump diaphragm (pump leaks)
- Discharge line leak
- Defective pressure switch

### Low Flow and Pressure

- Air leak at pump intake
- Accumulation of debris inside pump and plumbing
- Worn pump bearing (excessive noise)
- Punctured pump diaphragm (pump leaks)
- Defective motor

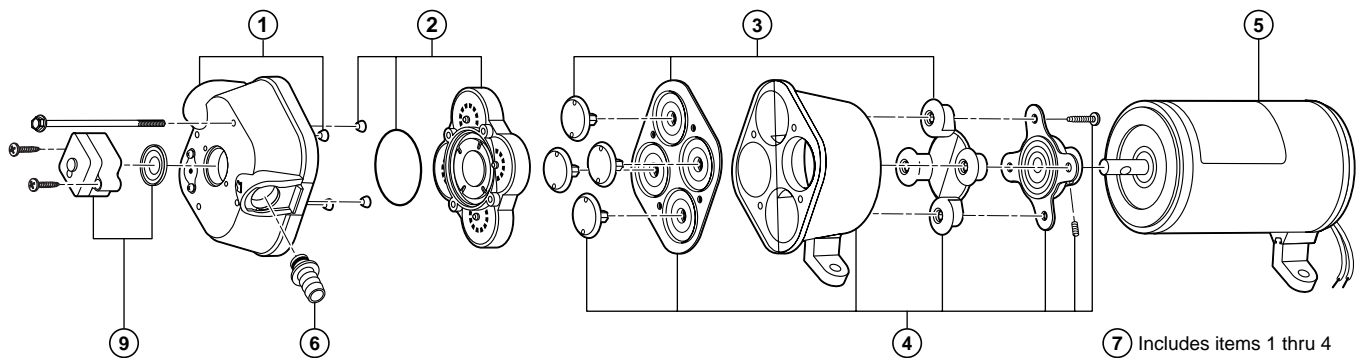

Quite often when a pump is worn or defective the one failed component has overburdened others. To avoid frequent aggravating repairs, Flojet offers service kit assemblies making repairs as quick and easy as possible.

## DISASSEMBLE

### Pressure Switch

1. Remove switch (9). Disconnect switch wires.

### Upper Housing

2. Loosen but do not remove four pump head screws and carefully remove upper housing assembly (1)
3. Inspect check valve (2) for debris
4. Reassemble new upper housing (1)

### Check Valve Assembly

Follow step 2

3. Replace check valve (2)
4. Reassemble upper housing (1)

### Lower Housing, Diaphragm, Motor

Follow step 2, then slide rubber foot from mounting track.

3. Rotate lower housing (4) so mounting notch opening on lower housing exposes set screw which holds bearing housing to shaft.
4. Loosen this set screw by inserting wrench 1/8" Allen wrench into mounting notch opening. Then, slide lower housing (4) off motor shaft.

### Diaphragm Cont'd

5. Loosen four cam piston screws with Phillips head screw driver and pull apart cam from inner pistons. (Pistons should always be replaced when a new diaphragm is installed.)

### Motor Cont'd

5. Replace Motor

## REASSEMBLE

### Motor

1. Reassemble lower housing assembly (4) to motor. (Follow steps 4 to 10.)

### Diaphragm

2. Lower housing is assembled with:
  - Flat side of diaphragm and outer pistons facing motor
  - Hex stem of inner pistons must be aligned into hex holes in outer pistons (4).
  - Outer pistons must be aligned with alignment slots on cam assembly making sure screw holes align in cam assembly, otherwise diaphragm will leak.
3. Tighten cam piston screws partially, center piston in diaphragm, then tighten screws securely (18 in. lbs. torque)

### Lower Housing

4. Reassemble lower housing assembly (4) to motor.
5. Retighten set screw securely. Set screw head must be positioned facing motor covering seam (indentation). (Positioning of this screw is critical to avoid misalignment and subsequent diaphragm damage.)

### Upper Housing, Check Valve

6. Reassemble upper housing (1)
7. Properly seat O-Ring in check valve assembly (2) and check if feeler rules and screen are in place on upper housing (1)
8. Install check valve (2) into upper housing (1) and push in.
9. Assemble on to lower housing (4), align 4 screws on to motor by rotating lower housing (4) if necessary to align feet
10. Tighten screws evenly to 30 in. lbs. torque.

### Pressure Switch

1. Place switch against front of pump (9), insert screws and take care not to cross thread or strip out threads in housing.
2. Reconnect wires.

## WASHDOWN PUMP SERVICE PARTS

KEY#	DESCRIPTION	MODEL#				
		4325-143	4325-343	4325-443	4325-043	4325-243
0	Service Kit*	20409-043	20409-043	20409-043	20409-043	20409-043
1	Upper Housing With Clips	20404-003	20404-003	20404-003	20404-003	20404-003
2	Check Valve Assembly	20407-030	20407-030	20407-030	20407-030	20407-030
3	Diaphragm Assembly (includes screws)	20403-040	20403-040	20403-040	20403-040	20403-040
4	Lower Housing Assembly	20419-002	20419-002	20419-002	20419-002	20419-002
5	Motors	2009-080A	2019-027A	2049-026A	—	—
	Motors CE Models	R2009-080A	R2019-027A	—	—	—
	Motor 115 Volt a.c./230 Volt a.c.	—	—	—	2029-091A	2039-087A
6	Ports - 3/4 Barb (pair)	20381-006	20381-006	20381-006	20381-006	20381-006
7	Pump Head Assembly	20406-002A	20406-002A	20406-002A	20406-002A	20406-002A
8	Side Clips (pair)	20408-000	20408-000	20408-000	20408-000	20408-000
9	Pressure Switch Assembly	02090-118	02090-118	02090-118	02090-118	02090-118

\*Service Kit includes #2, #3, #8 and drive cam assembly.

## ACCESSORIES

### QUICK CONNECT PORT SYSTEM

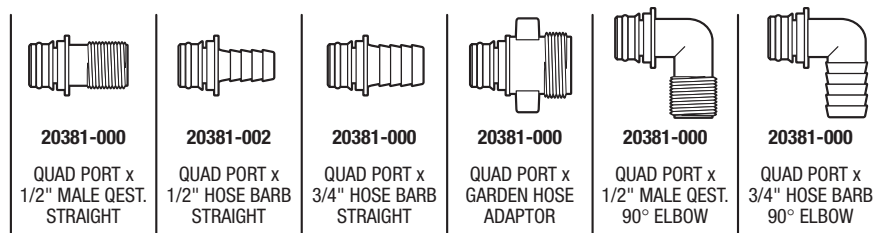

The above part numbers are packaged with 2 fittings per bag.

## STRAINERS

	Pump Series	Strainer Number	Inlet	Outlet	Screen
<b>STRAINER</b>	4325-XXX	1740-000	3/4 Barb	3/4 Barb	40 Mesh
<b>PRESSURE NOZZLE</b>	4325-XXX	20446-000	3/4 GH	—	—

## WARRANTY

FLOJET warrants this product to be free of defects in material and/or workmanship for a period of two years after purchase by the customer from FLOJET. During this two year warranty period, FLOJET will at its option, at no charge to the customer, repair or replace this product if found defective in material or workmanship, with a new or reconditioned product, but not to include costs of removal or installation.

This is only an overview of our limited warranty. If you would like a copy of our warranty, please call or write FLOJET.

## RETURN PROCEDURE

Prior to returning any product to FLOJET, call customer service for an authorization number. This number must be written on the outside of the shipping package. Place a note inside the package with an explanation regarding the reason for return as well as the authorization number. Include your name, address and phone number.

## Flojet

U.S.A.  
Flojet  
20 Icon  
Foothill Ranch, CA 92610-3000  
Tel: (949) 859-4945  
Fax: (949) 859-1153

UNITED KINGDOM  
Jabsco/Flojet  
Bingley Road, Hoddesdon  
Hertfordshire EN11 0BU  
Tel: +44 (0) 1992 450145  
Fax: +44 (0) 1992 467132

CANADA  
Fluid Products Canada  
55 Royal Road  
Guelph, Ontario N1H 1T1  
Tel: (519) 821-1900  
Fax: (519) 821-2569

JAPAN  
NHK Jabsco Company Ltd.  
3-21-10, Shin-Yokohama  
Kohoku-Ku, Yokohama, 222  
Tel: 045-475-8906  
Fax: 045-475-8908

GERMANY  
Jabsco GmbH  
Oststrasse 28  
22844 Norderstedt  
Tel: +49-40-53 53 73-0  
Fax: +49-40-53 53 73-11