

# 320R-RAC Series

## Gasoline Fuel Filter/Water Separators

Instruction Part Number 22237 Rev. D



### Overview:

Racor 320R-RAC series filters are designed for high-performance applications, which means your engine will perform better than ever with clean, water-free fuel.

The spin-on filter is simple to replace and re-useable clear plastic (or metal) contaminant collection bowl features a self-venting drain (or metal plug) for removing unwanted muck and water.



### Contact Information: Product Features:

Parker Hannifin Corporation  
**Racor Division**  
P.O. Box 3208  
3400 Finch Road  
Modesto, CA 95353

phone 800 344 3286  
209 521 7860  
fax 209 529 3278  
racor@parker.com

[www.parker.com/racor](http://www.parker.com/racor)  
[www.parker.com/racorproducts](http://www.parker.com/racorproducts)

- 320R-RAC-02 is UL listed and USCG approved for inboard marine use
- High-capacity 10 micron Aquabloc®II media
- 60 GPH (227 LPH) maximum flow rate
- Superior corrosion resistance with electrostatic powder coating
- 3-port die-cast aluminum mounting head with 1/4"-18 NPTF threads
- Removes 99% of free water



ENGINEERING YOUR SUCCESS.

# Mounting Information

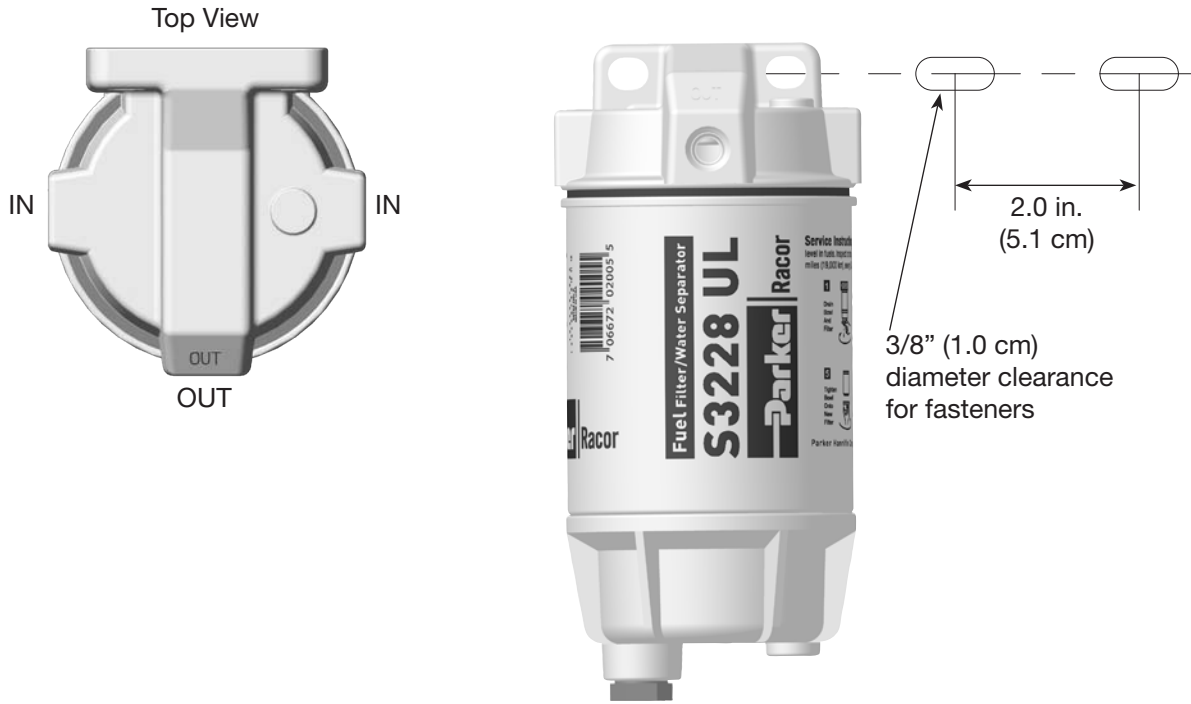

# Installation Diagram

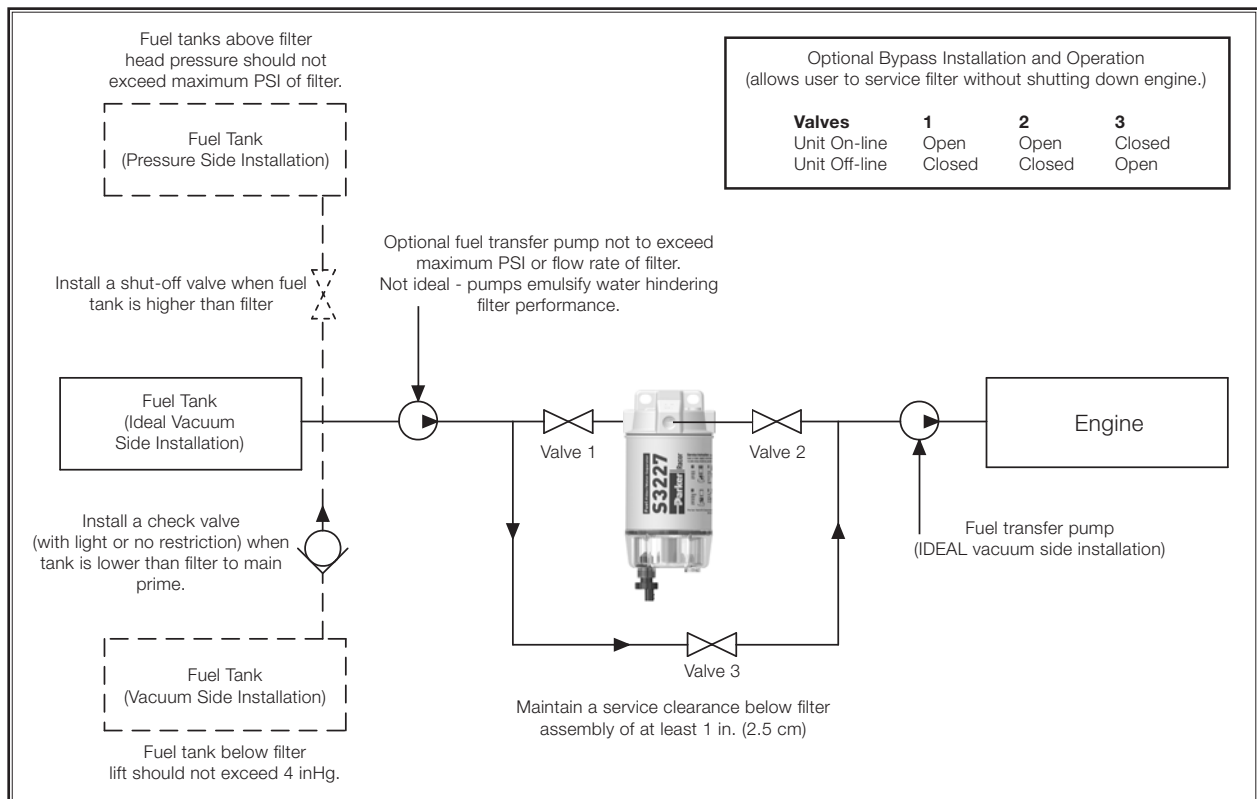

# Installation Guidelines

**Danger! Great care must be exercised to avoid potential fire hazards during installations on gasoline fuel systems. Do not smoke or permit open flames or sparks near the fuel system.**

1. Any secondary or pressure side filters located between pump and engine should be serviced and left in place.
2. Mount unit vertically on suction side of fuel pump, transfer pump, or non-removable filters, whichever comes first.
3. Ensure a suitable pipe thread sealing compound is used on NPT threads of fitting prior to installation into head. For mounting flexibility, there are two inlet ports and one outlet port. Plated steel fittings are recommended. Plug unused port with provided steel NPT plug - *do not use tapes on NPT threads.*
4. Use quality fuel hose in maximum fuel line size applicable to reduce potential fuel flow restrictions.  
*Note: USCG accepted hose recommended. Contact your Racor distributor for your application requirements.*

## Priming The Unit

1. Carefully spin off bowl/filter as one and fill both with clean fuel (use a strap wrench near top of element to remove and avoid damage).

2. Spin bowl/filter onto mounting head and tighten snugly by hand - *do not use tools to tighten.*
3. Start engine and check for leaks. If engine is difficult to start or runs rough, check that drain, bowl, filter, and port plug are securely tightened. Check all connections for security and hoses to ensure there are no kinks or sharp bends that would create excessive restriction.

## Service

**Danger! When servicing gasoline fuel systems, extreme care must be exercised to avoid potential fire hazards. Do not smoke or permit open flames near fuel system during servicing procedures.**

## Draining the Collection Bowl

Water is heavier than fuel and will settle at bottom of bowl and appear different in color. In extremely humid conditions, take a fuel sample (in clear container) frequently, daily, if needed and drain as required if water is present.

1. Place a suitable container below unit to collect contaminants.
2. Close fuel tank valve (if applicable), then open Racor self-venting drain (-01 model) or loosen/remove drain plug (-02 model) at bottom of bowl. *Note: a UL listed drain valve kit is available for -02 models, order part no. RK 19492.*
3. Prime fuel system following the manufacturer's procedure - refer to Priming The Unit.

## Filter Replacement

Filter replacement frequency is determined by contamination levels in fuels. Fuel flow to engine becomes restricted as filter slowly plugs with contaminants, resulting in noticeable power loss and/or hard starting. Replace filter annually, every 100 hours, or when there is a noticeable power loss, whichever comes first. Change filter as soon as possible. *Note: always carry extra replacement filters as one tankful of excessively contaminated fuel can plug a filter.*

Clean any debris or dirt away from Racor head/filter joint prior to removal.

1. Place a suitable container below unit to collect contaminants.
2. Close valve at fuel tank (if applicable) open or remove drain (plug) to empty Racor filter of fuel.
3. Spin filter and bowl off together (use a strap wrench on filter), then remove bowl from filter.
4. Clean, bowl O-ring gland and sealing surface of mounting head, of dirt, debris, or gums.
5. Apply lube oil to new seal and bowl O-ring supplied with new filter.
6. Place new seal onto top of new filter and O-ring into bowl gland.
7. Spin bowl onto filter, then both onto head. Tighten snugly by hand - *do not use tools to tighten.*
8. Prime fuel system following manufacturer's procedure - refer to Priming The Unit.

# Troubleshooting Procedures

A major cause of power loss or hard starting is result of an air leak (or clogged filter). If your unit will not prime or fails to hold prime, check that drain,

bowl, and filter are properly tightened. Next, check all fitting connections and ensure fuel lines are not pinched or clogged with contaminants. If problems

persist (and filter is new) call Racor Technical Service for assistance: (800) 344-3286 or (209) 575-7555.



Specifications	320R-RAC-01	320R-RAC-02
<b>Application:</b> Inboard Outboard	No Yes	Yes Yes
<b>Maximum Flow Rate</b>	60 GPH (227 LPH)	60 GPH (227 LPH)
<b>Center Threads</b>	1"-14	1"-14
<b>Port Size</b>	1/4"-18 NPTF	1/4"-18 NPTF
<b>Number of Ports:</b> Inlets Outlets	2 1	2 1
<b>Height</b>	9.3 in. (23.6 cm)	9.0 in. (22.8 cm)
<b>Width</b>	4.0 in. (10.2 cm)	4.0 in. (10.2 cm)
<b>Depth</b>	4.0 in. (10.2cm)	4.0 in. (10.2cm)
<b>Weight (dry)</b>	2.0 lb (0.90 kg)	2.0 lb (0.90 kg)
<b>Clean Pressure Drop</b>	0.61 PSI (4.23 kPa)	0.61 PSI (4.23 kPa)
<b>Maximum Pressure</b>	7 PSI (0.5 bar)	7 PSI (0.5 bar)
<b>Underbowl Clearance</b>	1.0 in. (2.5 cm)	1.0 in. (2.5 cm)
<b>Water Removal Efficiency</b>	99%	99%
<b>Ambient Temperature Range</b>	-40° to +255°F (-40° to +124°C)	
<b>Maximum Fuel Temperature</b>	190°F (32°C)	

# Accessories

## Hose

Racor fuel hose is fire resistant and meets SAE J1527 Type A class and SAE J1942 standards. This hose delivers test proven performance

in a wide operating temperature range, constant working pressure in popular sizes, long-lasting reinforced construction, kink and

cut resistance, and compatibility with a variety of standard fittings.



Part Number	Hose ID	Working Pressure	Burst Pressure	Min. Bend Radius
CGH-5	1/4" (6.3 mm)	500 PSI (3.5 MPa)	2000 PSI (14 MPa)	1" (25 mm)
CGH-6	5/16" (8 mm)	500 PSI (3.5 MPa)	2000 PSI (14 MPa)	1 1/4" (30 mm)
CGH-8	13/32" (10 mm)	500 PSI (3.5 MPa)	2000 PSI (14 MPa)	1 3/4" (45 mm)

**Note:** Additional sizes may be available - call Racor at 1.800.344.3286

### Additional Features

- High-tensile steel wire braid.
- No-Skive - does not require the removal of outer cover to install.
- USCG-rated for gasoline, diesel, lube oil and hydraulic systems.
- Working temperature of -4°F to +212°F (-20°C to +100°C).

## Drain Valve Kit

UL Listed drain valve kit is available for -02 models. Part number RK 19492.



## RK 22628 Bowl Wrench

Hand wrench to removes all metal and clear spin-on bowls that feature external ribs.



# Performance Information

Test results are from controlled laboratory testing. Field results may vary.

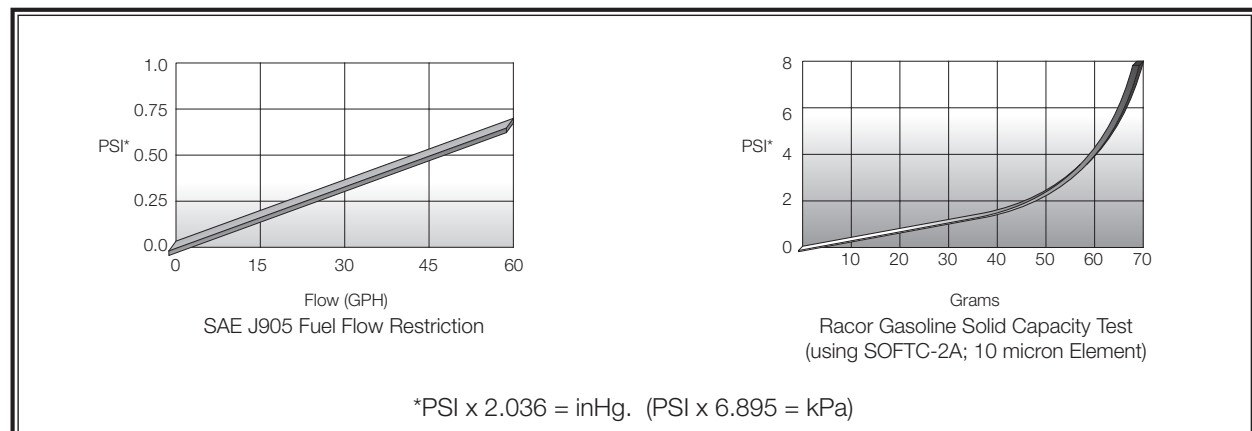

# 320R-RAC-01 Replacement Parts

<u>Part No.</u>	<u>Description</u>
1. RK 20180	Mounting Head Kit
2. 20707	Gasket Kit
3. S3227	10 Micron Replacement Filter
4. RK 22244	Bowl O-ring Kit
5. RK 30475	Clear Bowl Kit
6. RK 30476	Self-venting Drain Kit

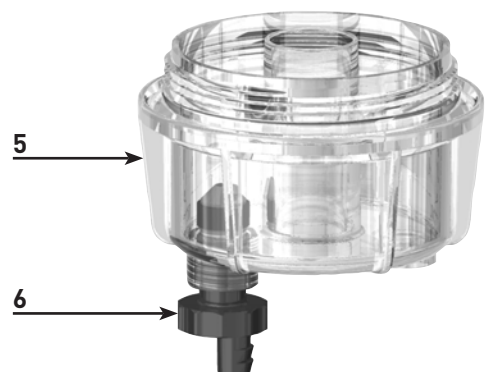
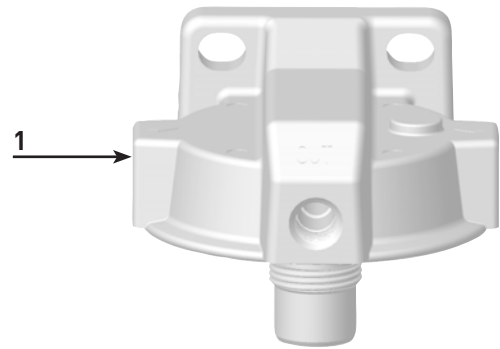

# 320R-RAC-02 Replacement Parts

<u>Part No.</u>	<u>Description</u>
1. RK 20180	Mounting Head Kit
2. 20707	Gasket Kit
3. S3228 UL	10 Micron Replacement Filter
4. RK 22244	Bowl O-ring Kit
5. RK 30473-02	Metal Bowl Kit
6. 918-N6	Steel Port Plug

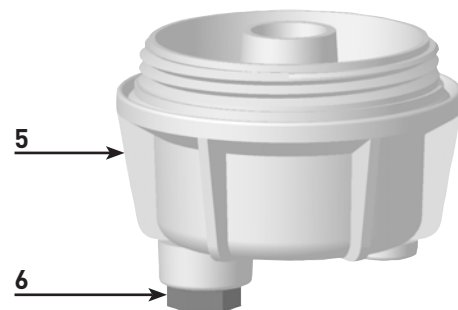
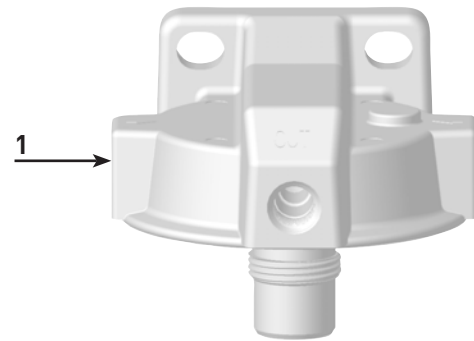

# Limited Warranties Statement

All products manufactured or distributed by Racor are subject to the following, and only the following, LIMITED EXPRESS WARRANTIES, and no others: For a period of one (1) year from and after the date of purchase of a new Racor product, Racor warrants and guarantees only to the original purchaser-user that such a product shall be free from defects of materials and workmanship in the manufacturing process. The warranty period for pumps and motors is specifically limited to ninety (90) days from date of purchase. A product claimed to be defective must be returned to the place of purchase. Racor, at its sole option, shall replace the defective product with a comparable new product or repair the defective product. This express warranty shall be inapplicable to any product not properly installed and properly used by the purchaser-user or to any product damaged or impaired by external forces.

THIS IS THE EXTENT OF WARRANTIES AVAILABLE ON THIS PRODUCT. RACOR SHALL HAVE NO LIABILITY WHATSOEVER FOR CONSEQUENTIAL DAMAGES

FLOWING FROM THE USE OF ANY DEFECTIVE PRODUCT OR BY REASON OF THE FAILURE OF ANY PRODUCT. RACOR SPECIFICALLY DISAVOWS ALL OTHER WARRANTIES, EXPRESS OR IMPLIED INCLUDING, WITHOUT LIMITATION, ALL WARRANTIES OF FITNESS FOR A PARTICULAR PURPOSE (EXCEPT FOR THOSE WHICH APPLY TO PRODUCT OR PART THEREOF THAT IS USED OR BOUGHT FOR USE PRIMARILY FOR PERSONAL, FAMILY, OR HOUSEHOLD PURPOSES), WARRANTIES OF DESCRIPTION, WARRANTIES OF MERCHANTABILITY, TRADE USAGE OR WARRANTIES OR TRADE USAGE.

## Warning

Failure or improper selection or improper use of the products and/or systems described herein or related items can cause death, personal injury and property damage. This document and other information from Parker Hannifin Corporation, its subsidiaries and authorized distributors provide product

and/or system options for further investigation by users having technical expertise. It is important that you analyze all aspects of your application and review the information concerning the product or system in the current product catalog. Due to the variety of operating conditions and applications for these products or systems, the user, through its own analysis and testing, is solely responsible for making the final selection of the products and systems and assuring that all performance, safety and warning requirements of the applications are met. The products described herein, including with limitation, product features, specifications, designs, availability and pricing, are subject to change by Parker Hannifin Corporation and its subsidiaries at any time without notice.

The following statement is required pursuant to proposition 65, applicable in the State of California: 'This product may contain a chemical known to the State of California to cause cancer or reproductive toxicity'