



Models 29200-0120
29200-0240

12 Volt
24 Volt

ELECTRIC FLUSH PUMP

FEATURES

- Directly replaces Manual Pump Assembly
- Easy to install
- Fits all Jabsco manual toilets and others with optional adapters
- Simple to operate
- Built-in macerator

SPECIFICATIONS

Ports: Inlet - 3/4" Hose Barb; Discharge - Attach manual pump 1 1/2" discharge elbow

Motor: Permanent magnet type with ball bearings on double ended stainless steel shaft

Pumps: Two flexible impeller pumps mounted on opposite ends of double ended motor

Weight: 7 1/2 lb (3,4 kg)

Dimensions: 10-1/2" (267 mm) high, 3-3/8" (86 mm) wide, 5-7/8" (149 mm) deep, 40" (1000 mm) wire leads

APPLICATION

The Jabsco Electric Flush Pump will convert any Jabsco or PAR manual toilet to electric operation. It is assembled at the factory to fit the 29090-Series and 29120-Series toilets which have been in production since 1987. The flush pump assembly simply replaces the entire manual pump assembly and screws directly to the toilet base. In addition to Jabsco & PAR toilets, the flush pump will also fit the Brydon Boy, Mansfield (Sealand) 751, Raske & Van der Meyde RM69, and Taiwan Magnetics TMC 999 toilet models.

In order to install the Flush Pump on the following listed toilet models, the indicated optional mounting flange must be installed on the pump assembly.

Toilet Model	Pump Mounting Configuration	Flush Pump Mounting Flange Adaptor Kit
PAR	3 Hole	29060-0000
BRYDON BOY	Triangle	
GROCO HC	2 Hole	29125-0000
Mansfield 750		
GROCO HE	3 Hole	29080-0000
GROCO HF	Equilateral Triangle	
Raritan Compact	4 Hole	29110-0000
Raritan PH & PH II		
Sealand 752	Square Pattern	
Wilcox Crittenden	4 Hole	29128-0000
Head Mate 1460 C		
Wilcox Crittenden	Square Pattern	
Winner R4042C*		

* The Wilcox Crittenden Flange Kit includes a 90° discharge elbow and joker valve which must be used in place of the original elbow and joker valve. The Winner toilet requires minor repositioning of the discharge plumbing because the new discharge elbow will be lower and about 4 inches further from the toilet bowl.

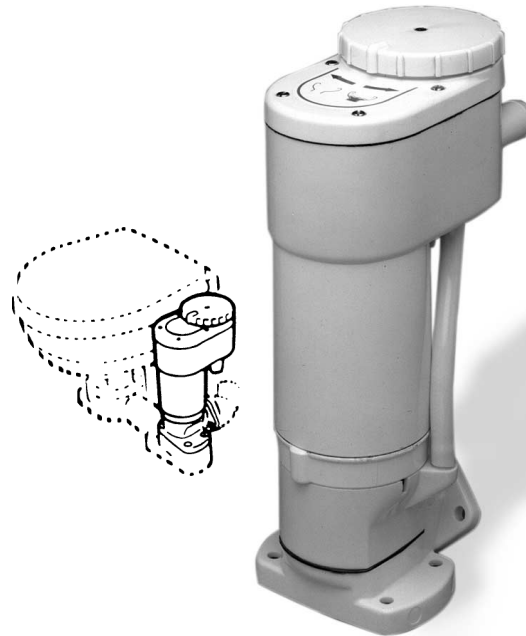

Models 29200-0120, 29200-0240

The pump may be installed on toilets which are mounted as high as 2 feet above the vessel's waterline or on toilets below the waterline if the total cumulative discharge head does not exceed 6 feet. It will fit toilets with either a compact size bowl or large household size bowl. Generally, the pump requires no modification or additions to the existing plumbing which services the manual pump assembly. However, if the discharge hose rises and falls repetitively and the total of all rising segments (when added together) exceeds 6 feet, it should be re-routed so the total cumulative rise is less than 6 feet. If this can not be done, the electric flush pump should not be installed.

INSTALLATION

⚠ WARNING Flood hazard. If toilet is installed below the waterline or may be below the waterline at any angle of heel or trim, it must be installed with properly positioned vented loops. Failure to do so can result in flooding which can cause loss of property and life.



The pump is assembled at the factory with a base mounting flange (macerator housing) which fits the 29090-Series and 29120-Series toilets. If the pump is to be installed on a PAR 59128-Series (Brydon Boy), Mansfield (Sealand) 751, Raske & Van Der Meyde RM69, Simpson Lawrence 444, or Taiwan Magnetics TMC 999, it is necessary to replace the four hole mounting flange with one of the optional mounting flanges listed in the Application section.

To change the mounting flange, remove the four screws (on bottom of pump assembly) which secure the mounting flange to the waste pump body. Note the relative position of the long and short screws.

Grasp the pump body, wearplate and motor with one hand, holding them together as an assembly. Then slide the mounting flange/macerator housing off the pump body with the other hand trying not to disturb the wearplate and damage the paper gaskets. It may be necessary to gently tap on the flange with a plastic mallet to start it sliding off the pump body.

If the gaskets are damaged, they should be replaced with new ones (provided) before attaching the new mounting flange/macerator housing. To do this insert a blunt rod dowel into the discharge hole in the pump body and push it against the impeller to prevent the motor shaft from turning. Unscrew and remove the chopper from the motor shaft. Lift the wearplate and gaskets from the pump body and clean any paper residue which may stick to the wearplate and body. Reassemble with new gaskets by reversing the procedure.

Before assembling the new mounting flange/macerator housing to the pump body, ensure the discharge port O-Ring is properly positioned in the O-Ring groove of the pump body. Secure the flange to the pump body with the two shorter screws and the pump assembly to the motor with the two longer screws.

Before removing the manual pump, flush the toilet for sufficient time to ensure all waste is thoroughly flushed from the discharge hose.

Remove the 3/4" inlet hose and toilet bowl link hose from the manual pump. Detach the discharge elbow, flange and joker valve assembly from the pump cylinder. It should not be necessary to remove the discharge hose from the elbow.

Remove the screws which secure the pump assembly to the toilet base and retain them to reattach the electric flush pump. Remove the manual pump assembly and the base flapper valve/gasket assembly with attached brass weight. The pump and flapper valve may be disinfected and stowed away for emergency use should the vessel lose electrical power.

Before assembling the electric flush pump to the toilet base, attach the discharge elbow, flange and joker valve to the flush pump discharge. Position the new pump base gasket (provided) on the toilet base. Align the flush pump mounting flange with the toilet base and secure it with the pump mounting screws.

Attach the 3/4" inlet hose to the inlet port (beneath the upper pump pointing down). Do not connect the pump inlet to a pressurized water system. Attach the bowl link hose to the flush pump discharge port (rear of upper pump pointing back). If the bowl link hose is not long enough or is kinked, replace it with the length of hose provided with the flush pump kit.

If the toilet is positioned below the waterline or may be below the waterline at any angle of heel or trim, the plumbing must include vented loops positioned above the waterline. To do this, remove the length of hose which connects the flush pump with the bowl. In its place install a length of hose long enough to connect the flush pump to a vented loop fitting positioned a minimum of 8 inches above the waterline. Connect the other side of the vented loop fitting to the bowl inlet elbow.

In below waterline installations with the discharge hose connected to a thru-hull fitting, the hose must rise up and be connected to a vented loop positioned a minimum of 8 inches above the waterline and then continue on to the discharge seacock. The total rise of the discharge hose, however, must not exceed 6 feet of head. If a vented loop fitting in the discharge hose positioned at least 8" above the waterline results in a total discharge head that exceeds 6 feet, the electric flush pump should not be installed.



WARNING Flood hazard. Close inlet and outlet seacocks prior to disassembling toilet. Failure to do so can result in flooding which can cause loss of property and life.

VENTED LOOP ILLUSTRATION

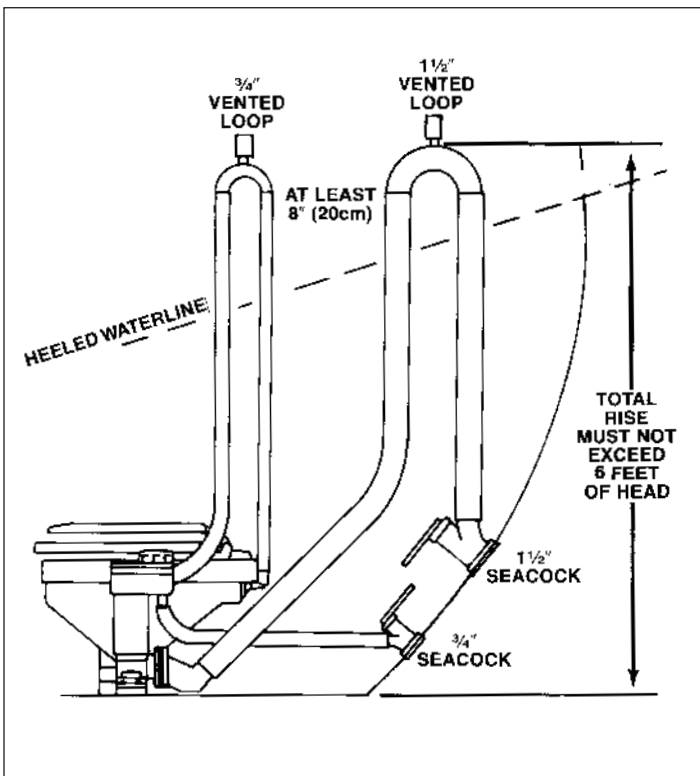

WIRING

The flush pump should be wired to the power source with an electrical circuit independent of all other accessories. The total length of wire should be kept to a minimum and the wire should be sized in accordance with the following electrical specifications chart. The wires, if not run through a conduit, should be supported every 18 inches with non-metallic clamps.

NOTICE: Correct wire size and secure wire connections are very important. Undersized wire and unsecured or corroded wire connections will cause a reduction in pump performance and possible pump failure.

The entire circuit should be protected by an appropriate size circuit breaker or switch panel located as close to the power source as possible.

Connect the red motor lead to positive and the black motor lead to negative. When making connections to the motor leads use only mechanical locking (crimp type) connectors or equivalent and seal the connection with silicone or heat-shrink tube to protect it from corrosion.

RATED VOLTAGE	NOMINAL AMPS	FUSE SIZE	WIRE SIZE PER LENGTH OF RUN*				
			0'-10'	10'-15'	15'-25'	25'-40'	40'-60'
12	24	25	12	10	8	6	4
24	13	15	16	14	12	10	10

*Length of run is the combined distance from the positive power source to the flush pump and back to ground. Wire sizes recommended will allow no more than a 5% drop in voltage.

OPERATION

NOTICE: Do not run pump dry for more than ten seconds. To do so may result in damage to the pump impeller.

To flush the toilet simply turn the large flush control knob clockwise to the flush position. In the flush position the flush Pump provides rinse water to the bowl while the waste pump simultaneously macerates and discharges the waste. Hold it in the flush position long enough to evacuate all waste.

To evacuate liquid from the bowl so it will not slosh while underway, turn the flush control knob counterclockwise to the drain position. In the drain position the flush pump will lower the liquid level to the bottom of the china bowl while incoming rinse water is reduced to a minimum.

If the toilet bowl is empty, a small amount of water may be added to the bowl prior to use by turning the flush control knob to the flush position.

The waste pump is designed to handle waste and toilet tissue (either household type tissue or Marine/RV water soluble tissue is acceptable) but it will not handle sanitary napkins, tampons or hard solid objects.

SERVICE INSTRUCTIONS



Flood hazard. Before performing any service, close all waste system seacocks. Failure to do so can result in flooding which can cause loss of property and life.

1. Disconnect the electrical power to the flush pump.
2. Detach the discharge elbow, flange and joker valve
3. Remove the inlet hose and toilet bowl link hose from the flush pump.
4. Remove the screws that attach the flush pump to the toilet base and lift the pump assembly from the base.

FLUSH PUMP DISASSEMBLY:

1. Remove the control knob screw and the control knob.
2. Remove the seven screws which attach the flush pump cover assembly to the pump body and lift off the cover assembly and the cork gasket.
3. Lift the brass wearplate and the flushing pump impeller out of the impeller bore.
4. Carefully lift the switch from the pump housing taking care not to lose the positioning dowel pin and gently disconnect the red wire leads.
5. Using a blunt punch or small piece of dowel inserted in the inlet port, push upward on the control valve assembly to dislodge it from the flush pump housing.
6. Remove the two screws which secure the flush pump housing to the motor and lift the pump housing off the motor.
7. Through the impeller bore side of the pump housing, push evenly against the shaft seal to press it out of the seal bore.

WASTE SYSTEM DISASSEMBLY:

1. Remove the flush pump to waste pump bleed tube.
2. Remove the four screws that secure the macerator housing and pump assembly together and to the motor. Note that they are two different lengths with the longer screws securing the pump assembly to the motor.
3. Grasp the waste pump body and motor then pull the

4. Remove the O-Ring around the discharge port.
5. Grip the flat of the shaft where it has been exposed by the remove top pump assembly to prevent it from rotating. Unscrew and remove the chopper and its lock washer.
6. Remove the wearplate and two gaskets from the pump assembly.
7. Remove the pump body and impeller from the motor then withdraw the impeller from the body.
8. Through the impeller bore side of the pump housing, push evenly against the shaft seal to press it out of the bore.

WASTE PUMP REASSEMBLY:

1. Press the lip seal into the seal bore of the pump body with the open side of the seal facing the impeller bore.
2. Lubricate the impeller bore of the body and the motor shaft with petroleum jelly then slide the pump body onto the shaft.
3. Slide the impeller onto the shaft and with a counter-clockwise motion push the impeller into the impeller bore.
4. Position a new paper gasket, wearplate and second paper gasket on the shaft against the pump body.
5. Grip the flat of the shaft on the top end of the motor to prevent it from turning. Install the chopper lock washer and the chopper on the bottom shaft.
6. Position the O-Ring in the O-Ring groove around the discharge port.
7. Slide the macerator housing onto the pump body and secure it with the two shorter screws.
8. Position the discharge flange on the same side of the motor where the wire leads enter the case and secure the pump assembly to the motor with the two longer screws.

FLUSH PUMP REASSEMBLY:

1. Press the lip seal into the bore of the pump body with the open side of the seal facing the impeller bore.
2. Lubricate the impeller bore of the body and the motor shaft with petroleum jelly.
3. Slide the pump body onto the shaft and secure it to the motor with two screws. Slide the impeller onto the shaft and with a clockwise rotary motion press it into the impeller bore of the body.
4. Push the inlet control valve assembly into the cylinder above the inlet port.
5. Position the switch spring on the spring locator post. Insert the dowel pin in the switch and slide the pin in its channel to position the switch. Connect the red power leads to the switch.
6. Press the brass wearplate into the impeller bore area ensuring the locator notch aligns with the locator tab in the body.
7. Position the cork gasket over the top of the flush pump housing. Position the flush pump cover on the housing and secure it with the seven long screws. Hint: When installing screws, press firmly downward on the screw and rotate it counterclockwise until you feel the thread 'click' into its groove, then screw it in until tight.
8. Position the control knob in its socket and secure it with one short screw. Install the Electric Flush Pump Assembly on the toilet base by following instructions for installation.
9. Attach the flush pump to waste pump bleed tube to the lower and upper bleed ports.

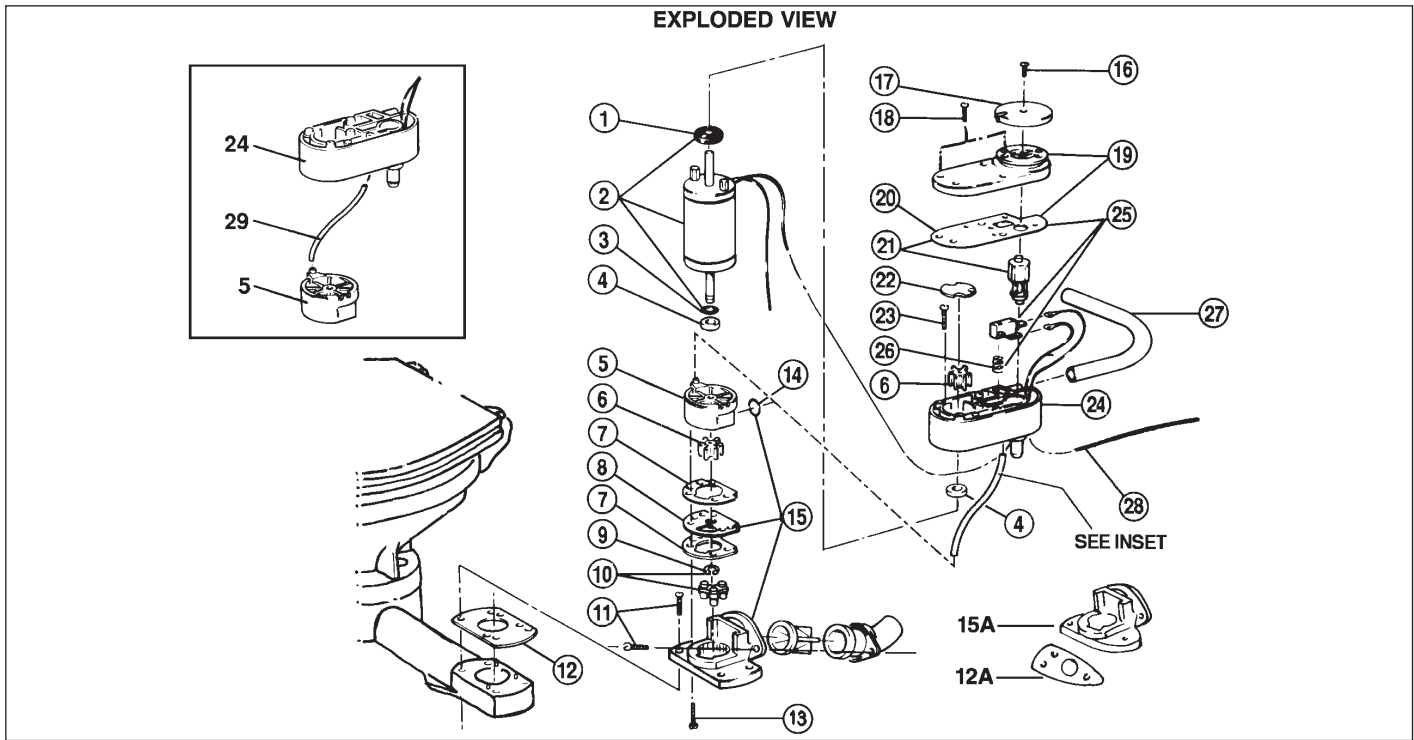

KEY	DESCRIPTION	QTY. PER TOILET	PART NO.	QTY. PER REPAIR KIT		
				A	B	C
1	SLINGER(Large)	1				
2	MOTOR ASSEMBLY 12V 24V		29108-0120 29108-0240			
3	SLINGER (Small)	1		1		
4	SEAL	2	18753-0384	2	2	
5	WASTE PUMP BODY	1				1
6	IMPELLER	2	6303-0003	2		
7	GASKET (Paper)	2	18753-0167	2	2	2
8	WEARPLATE (Stainless Steel)	1	18753-0168		1	
9	LOCKWASHER	1		1		
10	CHOPPER + SPRING WASHER	1	29102-1000			
11	MOUNTING SCREW (PAR)	-		1	1	
12	BASE GASKET (Rubber)	1	29072-1000			
13	SCREW (Waste Pump)	4			4	
14	O-RING	1	18753-0169	1	1	
15	MACERATOR HOUSING	1	29071-1000			
16	SCREW (Control Knob)	1		1	1	1

KEY	DESCRIPTION	QTY. PER TOILET	PART NO.	QTY. PER REPAIR KIT		
				A	B	C
17	CONTROL KNOB	1	29077-1000			
18	SCREW (Flush Pump Cover)			1	7	1
19	FLUSH PUMP COVER ASSY.	1	29081-1000			
20	FLUSH PUMP GASKET (Cork)	1	29075-1000	1	1	
21	CONTROL VALVE ASSY.	1	29083-1000	1	1	
22	WEARPLATE (Brass)	1	18753-0170		1	
23	SCREW Flush Pump)	1		1	2	1
24	FLUSH PUMP HOUSING	1				1
25	SWITCH ASSY.	1	29103-1000	1		
26	SWITCH SPRING	1	18753-0171			1
27	HOSE (All Toilets)	1	29035-1000			
28	CABLE ASSY.	1				
29	BLEED TUBE	1	29019-1010	1	1	1

REPAIR KITS AVAILABLE		
KIT	PART NO.	DESCRIPTION
A	29101-0000	SERVICE KIT
B	29109-0000	HARDWARE KIT
C	29116-1000	WASTE AND FLUSH PUMP HOUSING ASSYS

Jabsco



ITT Industries
Engineered for life

U.S.A.
Jabsco
20 Icon
Foothill Ranch, CA 92610-3000
Tel: (949) 609-5106
Fax: (949) 859-1254

UNITED KINGDOM
Jabsco
Bingley Road, Hoddesdon
Hertfordsire EN11 0BU
Tel: +44 (0) 1992 450145
Fax: +44 (0) 1992 467132

CANADA
Fluid Products Canada
55 Royal Road
Guelph, Ontario N1H 1T1
Tel: (519) 821.1900
Fax: (519) 821.2569

JAPAN
NHK Jabsco Company Ltd.
3-21-10, Shin-Yokohama
Kohoku-Ku, Yokohama, 222
Tel: 045.475.8906
Fax: 045.475.8908

GERMANY
Jabsco GmbH
Oststrasse 28
22840 Norderstedt
Tel: +49-40-53 43 73 -0
Fax: +49-40-53 53 73 -11

THE PRODUCTS DESCRIBED HEREIN ARE SUBJECT TO THE JABSCO ONE YEAR LIMITED WARRANTY, WHICH IS AVAILABLE FOR YOUR INSPECTION UPON REQUEST.