



SEATING OVERVIEW..... 194-195

AERGO SEATING SYSTEMS..... 196-197

MATRIX SEATING SYSTEMS..... 198-199

AVENIR SEATING SYSTEMS 200-203

DUAL HELM SEATING204

SAS BENCH SEATING205

CENTRIC II SEATING SYSTEMS 206-208

CENTRIC SEATING SYSTEMS 209-213

VENTURE SEATING SYSTEMS..... 214

PROFORM SEATING SYSTEMS 215

ABYC PEDESTAL REQUIREMENTS.....216

325 PEDESTAL SYSTEMS.....217

SEASPORT 2-7/8" PRODUCTS..... 218-219

LAKESPORT 238 SERIES PRODUCTS 220-221

238 SERIES 2-3/8" PRODUCTS..... 222-223

WEDGE 2" & 2-3/8" PRODUCTS..... 224

SNAP-LOCK 1.77" PRODUCTS225

LOCK 'N-PIN 3/4" PIN PRODUCTS 226-228

PEDESTAL ACCESSORIES..... 229-230

SEATING SYSTEMS

FIND A MATCH FOR EVERY BOATER'S STYLE OF COMFORT

Attwood introduces award-winning seating innovations, year after year. As the Attwood seating group grows, you can find the right seating style for every type of recreational boating, every type of customer.

Bucket Seating

For cruisers, runabouts, deck boats, and pontoon boats

Aergo

- Designed to be comfortable in any seating position
- Includes our 4-G mesh SAS suspension



Aergo

Matrix

- Ability to accept custom-shaped components offers the potential to create multiple levels of seating —from value-conscious to premium — from one platform
- Includes our 4G Mesh shock-absorbing suspension



Matrix

Avenir™

- Outstanding support, luxury, and styling
- Exclusive SAS™ Quad-Spring™ suspension offers unequalled shock absorption and comfort



Avenir



Avenir Sport

Bench Seating

For cruisers, yachts, pontoon, and center console boats.

Matrix Dual Helm

- Extra-wide seating for sharing the helm... or stretching out
- Flip-up bolster for stable, elevated seating and improved visibility
- Matches the style of the Matrix bucket seat



Dual Helm

SAS Bench

- Upholstery-ready platform that delivers what you need to create shock absorption seating
- Same technology and materials used in our award-winning SAS Quad-Spring seats



SAS Bench Seating Platform

Folding Seats

For all fishing boats and pontoon boats.

Centric II

- Ergonomically designed pan and back for ultimate comfort
- Seat pan designed for proper water drainage
- Larger seating surfaces
- Folds flat for a cleaner look



Centric II

Centric SAS™, Centric™ and Centric Contour

- Fold-down back allows unrestricted movement needed for active fishing
- Centric SAS adds shock absorption to soak up hull pounding



Centric Contour



Centric



Centric SAS

Venture™

- The best ergonomic contouring for cool comfort, with or without upholstery.
- Patented no-pinch folding hinge



Venture

PROForm®

- The long-time favorite for durability and comfort
- Many choices of shell and upholstery colors, including 2 camouflage styles



PROForm

THE FACTORS OF SEATING COMFORT

What makes a seat comfortable? The answer becomes complex as boating becomes more specialized and boaters more sophisticated. As your seating expert, Attwood stays ahead of design trends. In the columns below we list the universal and specialized comfort factors you should look for in any seat you choose.

UNIVERSAL FACTORS

Contouring

- The seat's backrest follows the natural curve of the spine
- An upward curve at back of the seat pan rotates the pelvis forward and properly positions the lumbar region
- A rounded front ("waterfall") edge reduces pressure on the thighs



Venture Fishing Seat is contouring in it's purest form

Backrest Angle

- The seat relieves pressure by shifting upper body weight to the backrest, while not reducing support. This is done by angling the seat and seat mount
- Optimal seat pan-to-backrest angle is 95° -105° for passengers, 95° - 100° for drivers

Seat Height

- Pedestal height is critical for comfort and driver's vision. If too low: weight shifts onto the sitting bones. If too high: weight shifts onto back of the thighs and into the spine
- Seat height should be adjustable within a 5" range — 14.5" to 19.5" above the deck

Proper Dimensions

- Seats should fit a range of body sizes
- Attwood's seats accommodate body frames ranging from small (5th percentile female) to large (95th percentile male)

SPECIALIZED FACTORS

Shock Absorption

- Attwood was the first to create effective shock absorption that isolates the boater's spine from hull pounding. Attwood accomplishes this through our two revolutionary seating suspension systems. Both take a 4-G hit without transferring shock to the rider by providing 3 inches of travel for a soft landing with no bottoming out.



SAS™ Quad-Spring Suspension



4G Mesh SAS Suspension

Cushioning

- If foam is too thick, the body "swims" without support, and movement is restricted
- If the foam is soft or thin, it "bottoms out," leading to discomfort or injury
- On Attwood seats, the right amount of sculpted foam enhances the comfort and support already designed into the ergonomic contour

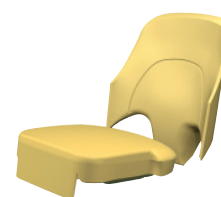

Breathability

- VisionAir™ Elastomeric Mesh Technology dissipates heat and moisture, offers cool comfort
- Venture folding fishing seats have ventilated seat back and pan to allow pass-through of air and water for increased comfort

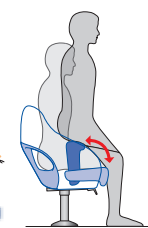
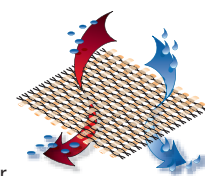

Accessories

- A flip-up bolster can add height and improve the field of vision for maneuvering
- The optional cargo panel on Matrix seats is a great way to stow your gear



SAS and 4G Mesh SAS Suspensions Provide Dynamic Comfort Underway and Static Comfort for Relaxing

What makes a seat comfortable? The answer becomes complex as boating becomes more specialized and boaters more sophisticated. As your seating expert, Attwood stays ahead of design trends. In the columns below we list the universal and specialized comfort factors you should look for in any seat you choose.

Dynamic Comfort

- While underway, both SAS suspension types absorb up to 4-Gs of impact from waves and hull pounding.

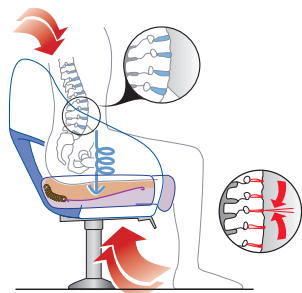

With Suspension
Impact is absorbed by the suspension — not the boater.

Without Suspension
Repeated impact can cause pain and chronic disk injury.

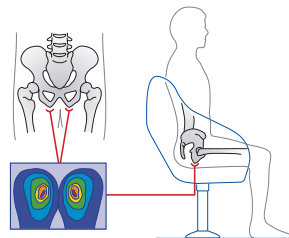

Static Comfort

Even while idle and sitting still, the SAS suspension adjusts to pressure and adds long term comfort..

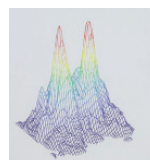

Conventional Seat
Graphs show that conventional seats allow pressure points and impaired circulation around sharp "sitting bones".

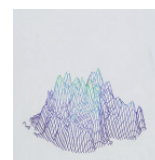

Seat with Suspension
The Attwood suspensions have stretching action to minimize pressure points.

AERGO SEATING

The new Aergo seats features show that it was definitely designed with comfort in mind. Angled back and cut-out allow the user to get a comfortable back angle in any seating position. Arm cap is angled in to keep arms in seat. The back of seat is pushed back to allow more seating area in the seat pan. A recessed arm area allows user to swing their leg over the side of the seat when turning to look behind the boat and the flip-up bolster allows additional height when trying to get the boat on plane. Aergo also possesses a feature that you expect in Attwood premium seating, the Mesh SAS Shock Absorbing System that absorbs up to 4-G's of shock.

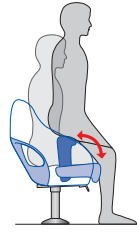

SAS SHOCK ABSORBING SYSTEM

Ergonomic In Any Position







Aergo Fully Upholstered Seats

The Aergo seat was designed to be comfortable in any seating position. Features the 4G mesh SAS shock absorbing system that absorbs up to 4-G's of shock. Available with 4 base colors and 12 accent color choices.

To Specify Base Color:

Specify one of the three base product numbers to indicate base color:

 Off-White Base Color = 98967 __-2	 Gray Base Color = 98968 __-2
 Bright White Base Color = 98966 __-2	 Tan Base Color = 98969 __-2

To Specify Accent Color:

Fill in blanks with the alpha code for accent color:

Example: Bright-White Base color with Red Accent = 98967RD-2

Accent Colors

Description	Code
 Burgundy	BG
 Red	RD
 Yellow	YE
 Beige	BE
 Tan	TN
 Gray	GY
 Smoke	SM
 Black	BK
 Blue	BL
 Green	GN
 Off-White	OW
 Bright White	BW

Description	Color	Bulk Packaging	Aftermarket Packaging
Aergo Fully Upholstered with Flip-up Bolster	Off-White	—	98967 __-2
Aergo Fully Upholstered with Flip-up Bolster Bright	White	—	98966 __-2
Aergo Fully Upholstered with Flip-up Bolster	Gray	—	98968 __-2
Aergo Fully Upholstered with Flip-up Bolster	Tan	—	98969 __-2

Example: 98967 BW-2 = Off-White Base Color with Bright White trim

For questions regarding Attwood's most up-to-date seating selections, or for assistance with your seating application, contact your Sales Representative or Attwood Customer Service (616.897.9241)

Aergo Seat Shell Kits

These new Aergo Kits contain all the molded foam and plastic in one! Our 4-G Mesh SAS Shock Absorbing System and molded-in armrests give extra functional elements to the design and ergonomic comfort of this seat.

Aergo Kit Components

These kits contain the molded core, pan, and bolster plastic and foam pieces. You can choose either the standard kit, which contains standard bolster foam, or the large bolster kit which has larger bolster foam for added comfort during elevated seating.



Description	Bulk Packaging	Aftermarket Packaging**
Kit with standard bolster	98961-1	—
Kit with large bolster	98963-1	—

MATRIX SEATING

Superior Styling, Unequaled Comfort and Infinite Design Possibilities

Matrix is the first seat built to accept custom-shaped components that give you the ability to build a completely original seating system.

Create your unique design with one of three standard seat core configurations. Then add arms and/or a headrest to change the overall appearance of the seat and craft a truly distinctive look.

Develop your concept by utilizing density-controlled molded foam packs.

Enhance your final design with optional accessories to turn your value conscious seat into a premium product.

Uses standard components and Ready-to-Go Seats or Create Your Own Design

SAS Shock Absorption in Every Seat

Every Matrix design provides two kinds of comfort with the SAS Mesh seat pan suspension system. Built into the core of every Matrix seat, the SAS Mesh Shock Absorbing System is completely integrated within the seat pan to simultaneously support the sculpted foam pack and absorb shock without transferring impact to the boater.

Static Comfort

- Elastic mesh will not deform under pressure. Always returns to its original tension without sagging
- Relieves pressure and improves circulation around the sharp “sitting bones”

Dynamic Comfort

- The elastic mesh absorbs a SAS upward thrust from hull pounding, without transferring that shock to the rider
- 3-inches of suspension travel always gives a soft landing with no hard bottom



SAS SHOCK ABSORBING SYSTEM

Matrix Fully Upholstered Seats

Our plush Matrix bucket seat features marine grade vinyl upholstery and thick foam padding along with SAS Mesh shock absorbing technology that takes a SAS hit without transferring shock to the rider. Seat also features a flip-up bolster for added seat height. Some models include a back panel with mesh cargo net to keep things organized.



98801/98803



98811/98813



98821/98823



Cargo Back Panel

Description	Bulk Packaging	Aftermarket Packaging
Off-White Upholstery, Bolster, No Cargo Panel	—	98801-2
Off-White Upholstery, Bolster, w/ Cargo Panel	—	98803-2
Bright-White Upholstery, Bolster, w/ Cargo Panel	—	98804-2
Off-White Upholstery, Arms, Bolster, No Cargo Panel	—	98811-2
Off-White Upholstery, Arms, Bolster, w/ Cargo Panel	—	98813-2
Bright-White Upholstery, Arms, Bolster, w/ Cargo Panel	—	98814-2
Off-White Upholstery, Arm/Headrest, Bolster, No Cargo Panel	—	98821-2
Off-White Upholstery, Arm/Headrest, Bolster, w/ Cargo Panel	—	98823-2
Bright-White Upholstery, Arm/Headrest, Bolster, w/ Cargo Panel	—	98824-2

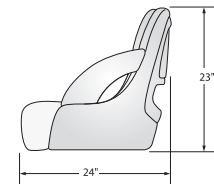



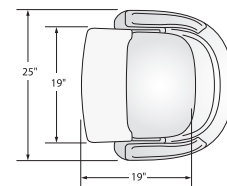

Dimensions



MATRIX SEATING COMPONENTS

Core Component Specifying Chart

1 Choose Seat Core Configuration	A. Basic Seat Core <ul style="list-style-type: none"> • Seat core • Bolster • 4G Mesh Seat Pan 	B. Seat Core with Arms <ul style="list-style-type: none"> • Seat core • Bolster • 4G Mesh Seat Pan • Left & Right Arms 	C. Seat Core with Arm-Headrest <ul style="list-style-type: none"> • Seat core • Bolster • 4G Mesh Seat Pan • Headrest & Arms 
	2 Choose Cargo Configuration	A. With Cargo Panel <ul style="list-style-type: none"> • Molded pack panel with elastic net for small-item storage • Order trim ring separately 	B. Without Cargo Panel <ul style="list-style-type: none"> • Includes back panel for upholstering over hole in seat core back 

Core Components

Start customizing by selecting from the standard Matrix components and accessories. Because Matrix is modular, you can select the configuration that matches the boater's needs. Then choose whether or not to add the optional cargo back panel that is perfect for storing small items and keeping them secured.

Configuration	Description	Bulk Packaging	Aftermarket Packaging
A-B	Seat Core, Bolster, No Cargo Panel	98261-1	—
A-A	Seat Core, Bolster, Cargo Panel Option*	98263-1	—
B-B	Seat Core w/Arms, Bolster, No Cargo Panel	98271-1	—
B-A	Seat Core w/Arms, Bolster, Cargo Panel Option*	98273-1	—
C-B	Seat Core w/Arm-Headrest, Bolster, No Cargo Panel	98281-1	—
C-A	Seat Core w/Arm-Headrest, Bolster, Cargo Panel Option*	98283-1	—



Configuration shown:
A-B 98261



91420



91418

Accessory Components

Description	Bulk Packaging	Aftermarket Packaging
CARGO PANELS		
White Cargo Panel	914120-001-1	—
Medium Gray Cargo Panel	914120-005-1	—
TRIM RINGS		
White Trim Ring	914118-001-1	—
Medium Gray Trim Ring	914118-005-1	—
Satin Aluminum Trim Ring	914118-065-1	—

Molded Foam Packs

Description	Bulk Packaging	Aftermarket Packaging
SEAT BACK FOAM PACKS		
Seat Back Foam (uncut)	ATT121	—
Seat Back Foam (cut)	ATT122	—
SEAT PAN & BOLSTER FOAM PACKS		
Large Bolster Foam	001002607	—
Bolster Foam	ATT120	—
Seat Pan	ATT119	—

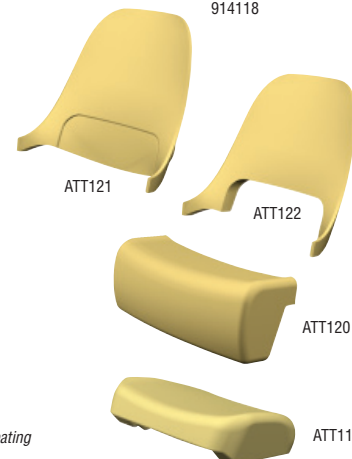

* Order Cargo Panel and Trim Ring separately.

For questions regarding Attwood's most up-to-date seating selections, or for assistance with your seating application, contact your Sales Representative or Attwood Customer Service (616.897.9241)

AVENIR™ SEATING

Avenir is the world's first bolster seat with the award winning, patented SAS shock absorbing system.

Seat Shell and Molded Foam

Work together to provide ergonomic comfort and spinal support.

Flip-Up Bolster

Bolster down creates rounded edge at front of seat and exceeds ABYC H-31 Type A Driver requirements. Up position holds the bolster at a 102° angle with 7" height for improved maneuvering vision or when boat is off plane.

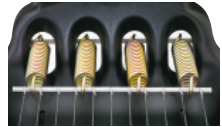
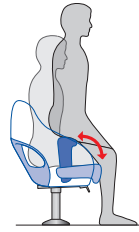

Spring Grid
Flexes with the coil springs and supports the seat foam. Continually adjusts for circulation and comfort.



Quad Spring Suspension
Provides comfort and 3" travel for shock absorption. Prevents rider from "bottoming out."

SAS SHOCK ABSORBING SYSTEM

Recessed Bottom Angle
Rounded corners and recessed bottom angle minimize the bottom "footprint." Allows seat to swivel in confined spaces.

No Exposed Hinges
No ugly brackets or fasteners to color-match, pinch, or abrade.

Avenir Fully Upholstered Seats

Avenir mid-back upholstered seats are trimmed out with a deep-tuck backrest, molded polyurethane foam, and marine grade vinyl upholstery. The curved arm supports arms in a natural comfortable position. The side cutaway provides lower back ventilation. Seats include corrosion-resistant T-nuts for attachments to pedestals. Available with 4 base colors and 12 accent color choices.

To Specify Base Color:

Specify one of the three base product numbers to indicate base color:

- Off-White Base Color = 98407 __-2
- Gray Base Color = 98409 __-2
- Bright White Base Color = 98408 __-2
- Tan Base Color = 98416 __-2

To Specify Accent Color:

Fill in blanks with the alpha code for accent color:

Example: Bright-White Base color with Red Accent = 98407RD-2



Description	Color	Bulk Packaging	Aftermarket Packaging
Avenir Fully Upholstered with Flip-up Bolster	Off-White	—	98407__-2
Avenir Fully Upholstered with Flip-up Bolster	Bright White	—	98408__-2
Avenir Fully Upholstered with Flip-up Bolster	Gray	—	98409__-2
Avenir Fully Upholstered with Flip-up Bolster	Tan	—	98416__-2

Accent Colors

Description	Code
Burgundy	BG
Red	RD
Yellow	YE
Beige	BE
Tan	TN
Gray	GY
Smoke	SM
Black	BK
Blue	BL
Green	GN
Off-White	OW
Bright White	BW

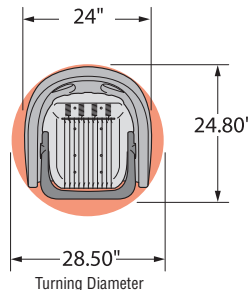
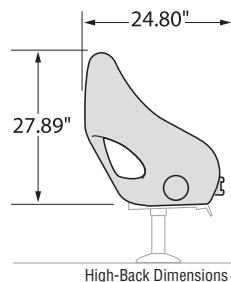
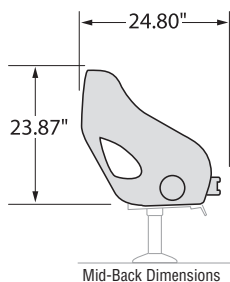

AVENIR SEATING COMPONENTS



Easy to Install...So It Saves Assembly Time and Cost

Avenir seating can reduce your upholstery and installation costs because it's refined to just four interlocking components. The only fasteners required are the bolts that attach it to seat pedestals with universal hole patterns. Avenir uses the marine grade materials tested and proven in Centric SAS seats — thermoplastic shell and stainless steel suspension grid with corrosionproof springs.

Avenir bulk-packaged components are available as convenient labor-saving kits, ready for upholstery. SAS seat pan includes corrosion-resistant T-nuts for attachment to seat pedestals. Fasteners used to attach the pedestal seat mount draw the seat shell and pan together by threading into the T-nuts located in the seat pan.



Mid Back Shell



High Back Shell

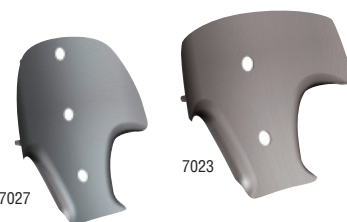

7027

7023



98170



7060

Seat Shell Kits

Avenir Seat Shell Kits includes one each of seat shell and backrest upholstery insert. The backrest upholstery insert speeds up the upholstery of the seat shell and provides an easy means of adding a stylish accent piece with deep-tuck seam. Insert posts snap securely into seat shell using foolproof clips for quick, easy assembly.

SAS Seat Pan and Bolster

Avenir's SAS Seat Pan is offered with or without Flip-up Bolster. When specifying molded foam packs for SAS seat pans, be sure to specify the correct corresponding with or without bolster part number.

Upholstery Trim Rings

Avenir Upholstery Trim Rings provide a finished cap to cover seam where mesh and vinyl meet in ventilation holes at back of seat. Custom colors are available based on a one-time colorant charge and minimum orders of 500 seats.

Description	For Use with Foam Pack	Bulk Packaging	Aftermarket Packaging
SEAT SHELL KITS			
Mid-Back Kit, w/onsert 7023	ATT103	98160-1	—
High-Back Kit, w/onsert 7027	ATT106	98164-1	—
SEAT PAN AND BOLSTERS			
SAS Seat Pan and Bolster	ATT101, ATT102	98170-1	—
SAS Seat Pan	ATT108	98171-1	—
TRIM RINGS			
Left Side Trim Ring, White Plastic		7060-1	—
Right Side Trim Ring, White Plastic		7040-1	—

Molded Foam Packs

Molded foam packs are contoured specifically to enhance Avenir's ergonomic design for maximum comfort and style. Eliminates labor intensive and costly cut foam and provides a consistent shape that improves the quality of the upholstered seat.

Description	For Use with Component	Bulk Packaging	Aftermarket Packaging
SEAT SHELL FOAM PACKS			
Mid-Back Shell	98160	ATT103	—
High-Back Shell	98164	ATT106	—
SEAT PAN FOAM PACKS			
SAS Seat Pan w/Bolster	98170	ATT101	—
SAS Seat Pan	98171	ATT108	—
BOLSTER FOAM PACKS			
Flip-up Bolster		ATT102	—

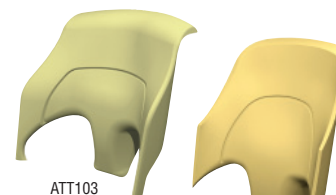

ATT103

ATT106

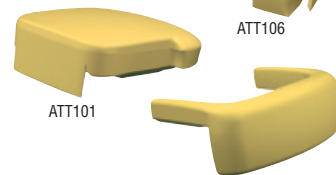

ATT101

ATT102



ATT108

For questions regarding Attwood's most up-to-date seating selections, or for assistance with your seating application, contact your Sales Representative or Attwood Customer Service (616.897.9241)

AVENIR™ SPORT SEATING

Avenir Sport has all the break-through features of the Avenir (SAS suspension system and flip-up bolster) but with a more compact, low profile, sporty styling. It's ideal for smaller cockpits or any application where boater comfort and compact size are important.

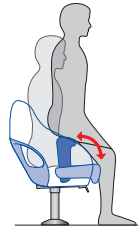

Arm Contour

Stylish curve supports the arms in a natural, comfortable position.

Flip-Up Bolster

Bolster down creates rounded edge at front of seat and exceeds ABYC H-31 Type A Driver requirements. Up position holds the bolster at a 102° angle with 7" height for improved maneuvering vision when boat is off plane. Avenir is the world's first bolster seat with the award winning, patented SAS shock absorbing system.



Spring Grid
Flexes with the coil springs and supports the seat foam. Continually adjusts for circulation and comfort.



Quad Spring Suspension
Provides comfort and 3" travel for shock absorption. Prevents rider from "bottoming out."

SAS SHOCK ABSORBING SYSTEM

Recessed Bottom Angle
Rounded corners and recessed bottom angle minimize the bottom "footprint." Allows seat to swivel in confined spaces.

No Exposed Hinges
No ugly brackets or fasteners to color-match, pinch, or abrade.





Avenir™ Sport Fully Upholstered Seats

Avenir™ Sport upholstered seats are trimmed out with a deep-tuck backrest, molded polyurethane foam, and marine grade vinyl upholstery. The side cutaway provides lower back ventilation. Seats include corrosion-resistant T-nuts for attachment to seat pedestals. Available with 4 base colors and 12 accent color options.

To Specify Base Color:

Specify one of the three base product numbers to indicate base color:

To Specify Accent Color:

-  Off-White Base Color = 98437__-2
-  Gray Base Color = 98439__-2
-  Bright White Base Color = 98438__-2
-  Tan Base Color = 98450__-2



Fill in blanks with the alpha code for accent color:

Example: Bright-White Base color with Red Accent = 98438RD-2

Description	Color	Bulk Packaging	Aftermarket Packaging
Avenir Sport Fully Upholstered with Flip-up Bolster	Off-White	—	98437__-2
Avenir Sport Fully Upholstered with Flip-up Bolster	Bright White	—	98438__-2
Avenir Sport Fully Upholstered with Flip-up Bolster	Gray	—	98439__-2
Avenir Sport Fully Upholstered with Flip-up Bolster	Tan	—	98450__-2

Accent Colors

Description	Code
Burgundy	BG
Red	RD
Yellow	YE
Beige	BE
Tan	TN
Gray	GY
Smoke	SM
Black	BK
Blue	BL
Green	GN
Off-White	OW
Bright White	BW

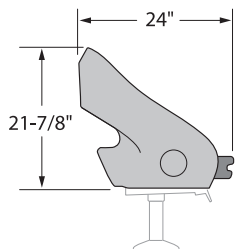
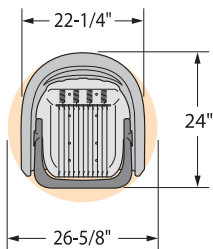

AVENIR SPORT SEATING COMPONENTS

Avenir Sport bulk-packaged components are available as convenient labor-saving kits, ready for upholstery. The Avenir Sport Seat Shell Kit can be outfitted with or without Flip-up Bolster; See “SAS Seat Pan and Bolster” offering for more details. SAS seat pan includes corrosion-resistant T-nuts for attachment to seat pedestals. Fasteners used to attach the pedestal seat mount draw the seat shell and pan together by threading into the T-nuts located in the seat pan.

Seat Shell Kits

Avenir Sport Seat Shell Kits includes one each of seat shell and backrest upholstery insert. The backrest upholstery insert speeds up the upholstery of the seat shell and provides an easy means of adding a stylish accent piece with deep-tuck seam. Insert posts snap securely into seat shell using foolproof clips for quick, easy assembly.



98190



7032

SAS Seat Pan and Bolster

Avenir Sport’s SAS Seat Pan is offered with or without Flip-up Bolster. When specifying molded foam packs for SAS seat pans, be sure to order the correct corresponding with or without bolster part number.

Description	For Use with Foam Pack	Bulk Packaging	Aftermarket Packaging
SEAT SHELL KITS			
Seat Shell Kit, onsert 7032	ATT109	98190-1	—
SEAT PANS AND BOLSTERS			
SAS Seat Pan w/ Bolster	ATT101, ATT102	98170-1	—
SAS Seat Pan	ATT108	98171-1	—

Molded Foam Packs

Molded foam packs are contoured specifically to enhance Sport’s ergonomic design for maximum comfort and style. Eliminates labor-intensive and costly cut foam and provides a consistent shape that improves the quality of the upholstered seat.

Description	For Use with Component	Bulk Packaging	Aftermarket Packaging
SEAT SHELL AND ONSERT FOAM PACKS			
Seat Shell and Onsert	98190	ATT109	—
Seat Shell and Onsert	98190, 7033	ATT110	—
SAS SEAT PAN AND BOLSTER FOAM PACKS			
SAS Seat Pan w/Bolster	98170	ATT101	—
SAS Seat Pan w/o Bolster	98171	ATT108	—
Flip-up Bolster	98170	ATT102	—

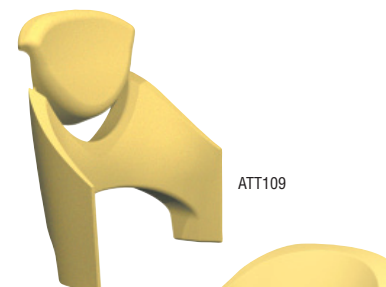

ATT109



ATT110



ATT101



ATT102

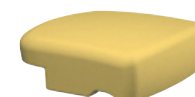

ATT108

For questions regarding Attwood’s most up-to-date seating selections, or for assistance with your seating application, contact your Sales Representative or Attwood Customer Service (616.897.9241)

DUAL HELM SEATING

Boating is more fun when it's shared.

A sporty bucket style has its applications. But sometimes a seat is just meant to be shared. Or sometimes you may need to stretch out at the helm. The Dual Helm seat is a roomy 42" wide. Perfect for sharing the helm... or lounging solo with all of the elbow room you could hope for. With the bolster up you have the clearer view, height, and support needed for closequarters maneuvering. With it down you have added leg support and a waterfall front edge for extra comfort.

The Dual Helm was developed for use on cruisers but is equally at home on center consoles, deck boats and pontoon boats.

Dual Helm is another new way that Attwood supports you with the seating sizes, configurations, and options that your customers want!

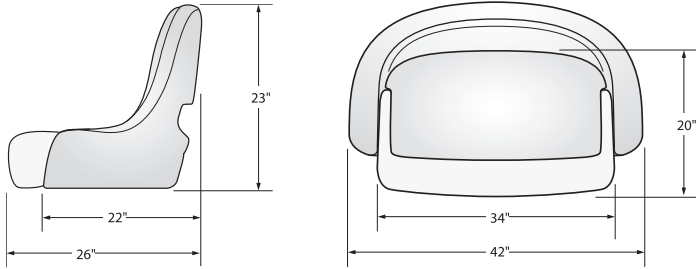

98220



98220
Bolster Up

Dual Helm Fully Upholstered Seats

Description	Bulk Packaging	Aftermarket Packaging
Dual Helm, fully upholstered, Off-White, With flip-up bolster	—	98220-2

DUAL HELM CORE COMPONENTS

Seat Shell Kits

The seat core and bolster components are blowmolded thermoplastic. They accept staples and are easy to upholster.

Foam Pack Kit

Foam pack kit includes foam for seat core, bolster and seat pan.

Description	Bulk Packaging	Aftermarket Packaging
SEAT SHELL KIT		
Includes Core, Bolster, Non-SAS Seat Pan	98210-1	—
FOAM PACK KIT		
Foam Packs for Core, Bolster, Seat Pan	ATT130	—

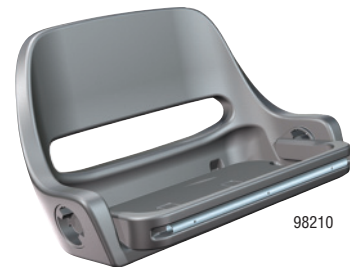

98210

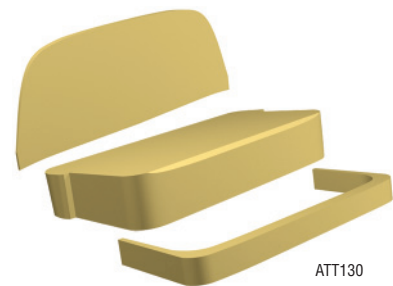

ATT130

SAS BENCH™ UPHOLSTERY-READY SEATING PLATFORMS

Here's the ideal way to design-in SAS™ shock absorbing benefits in a Bench Seat. Now available for OEM configuration.

- Use SAS Bench™ in helm, passenger, or single bench positions
- You can even gang it as a 2, 3, or 4-wide bench



SAS Bench is not a stripped-down version

It is simply simplified to the components that you need. The technology and materials are the same as those found in our award-winning fully fitted seats:

Standards and Specifications

All materials are marine-grade and designed for long lasting corrosion-resistance.

Simple Installation

The SAS Bench™ can be installed directly to the substrate through the bottom or front. The front lip is self-locating and can be attached to the substrate.

SAS Bench™ Seating

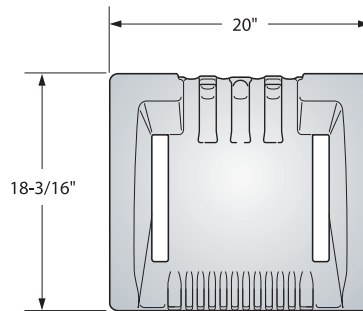
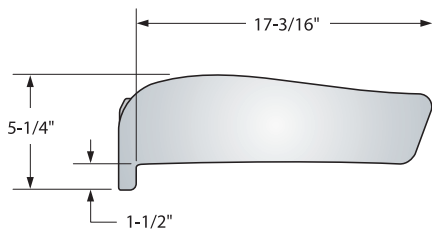

Description	Bulk Packaging	Aftermarket Packaging
SAS Bench™ Upholstery-Ready Modular Seating Platform	98151-1	—



SAS Bench Bucket™ Seating

Description	Bulk Packaging	Aftermarket Packaging
SAS Bench Bucket™ Upholstery-Ready Seating Platform, Spring Grid Suspension	001001204	—
SAS Bench Bucket™ Upholstery-Ready Seating Platform, Mesh Suspension	001004418	—



For questions regarding Attwood's most up-to-date seating selections, or for assistance with your seating application, contact your Sales Representative or Attwood Customer Service (616.897.9241)

CENTRIC II SEATING

The next generation in folding boat seats

Centric II has new features and state-of-the-art styling that make it the next generation in folding boat seats. Ergonomically designed to deliver maximum comfort with larger seating surfaces, the Centric II offers more features than the competition and does it in a compact footprint. All Centric II seats offer contoured pans designed to prevent standing water, integrated hand grips for stability, and a clean look in the 'closed' position. The SAS suspension is an option for the more advanced applications, where maximum comfort and support is desired. The seat back lock down mechanism is another option that separates the Centric II from the competition, as it delivers the positive locking in the folded position. The styling, functionality, and performance of the Centric II are why it is used on the boats of today's elite professional fishermen.

Call your Attwood Sales rep. for availability and specifications

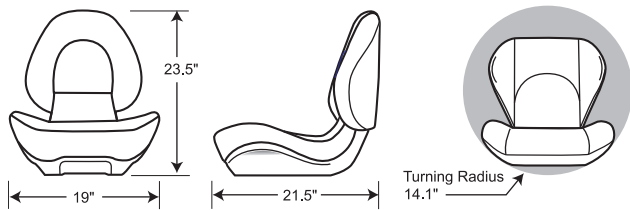

Custom OEM Version

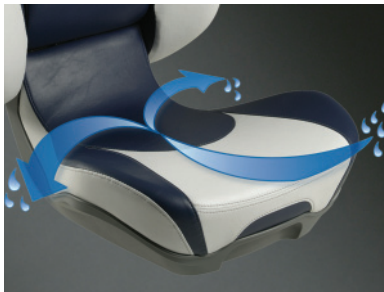

Seat Pan Designed For Proper Water Drainage



Folds Flat for a Cleaner Look



Larger Seating Surfaces



Optional Seat Back Lock-Down Button

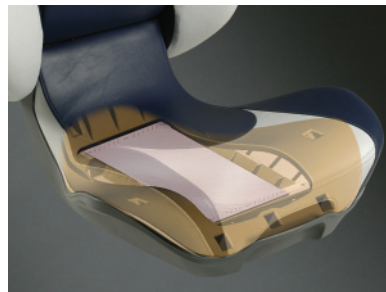

Optional 4-G Seat Mesh SAS Suspension



Ergonomically Designed Grab Landings

Centric II Seating Fully Upholstered Seats

Centric II Seats are trimmed out with deep tuck upholstered backrest, molded polyurethane foam, and marine-grade vinyl upholstery. Choose from 2 seat base colors, and 12 accent color options. Lock Down Button on back of seat is an optional feature. Seats include corrosion-resistant t-nuts for attachment to pedestals.

To Specify Seat:

Select seat description and base color below and add accent color code (from the chart on the right) to the part number. Example: 98971BL-2 = Centric II standard seat, Tan base upholstery with Blue Accents

Description	Color	Bulk Packaging	Aftermarket Packaging
Centric II Fully Upholstered, Standard	Gray	—	98970__-2
	Tan	—	98971__-2
Centric II Fully Upholstered, w/Seat Back Lock-Down Button	Gray	—	98970L__-2
	Tan	—	98971L__-2



Centric II SAS Seating Fully Upholstered Seats

Centric II SAS Seats are trimmed out with deep tuck upholstered backrest, molded polyurethane foam, marine-grade vinyl upholstery and Attwood's 4-G Mesh SAS suspension that absorbs up to 4-G's of shock. Choose from 2 seat base colors, and 12 accent color options. Lock Down Button on back of seat is an optional feature. Seats include corrosion-resistant t-nuts for attachment to pedestals.

To Specify Seat:

Select seat description and base color below and add accent color code (from the chart on this page) to the part number.

Example: 98870LRD-2 = Centric II SAS seat with Lock-Down Button, Gray base upholstery with Red Accents

SAS SHOCK
ABSORBING
SYSTEM

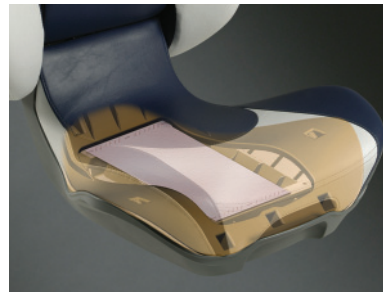

Description	Color	Bulk Packaging	Aftermarket Packaging
Centric II SAS Fully Upholstered, Standard	Gray	—	98980__-2
	Tan	—	98981__-2
Centric II SAS Fully Upholstered, w/Seat Back Lock-Down Button	Gray	—	98980L__-2
	Tan	—	98981L__-2

Accent Colors

Description	Code
Burgundy	BG
Red	RD
Yellow	YE
Beige	BE
Tan	TN
Gray	GY
Smoke	SM
Black	BK
Blue	BL
Green	GN
Off-White	OW
Bright White	BW

CENTRIC II SEAT COMPONENTS

Centric II seats are the next generation of Centric Seating. These sleek, functional, and ergonomically designed seats provide the new look you've been looking for in folding fishing or helm seats! Just choose the base plastic kit that suits your functional needs. Then choose a stylish foam kit and complete your look.



Seat Shell Kits

Centric II seat shell kits contain all plastic components to assemble our new Centric II seating line. Our options include special features such as our SAS Shock Absorbing System, locking backs with button, and gray or duck base colors. Base pieces include corrosion resistant T-nuts for pedestal attachment.

Description	For Use with Foam Pack	Bulk Packaging	Aftermarket Packaging
Non-SAS, Non-Locking, Gray	ATT200-1, ATT205-1, or ATT210-1	98900-1	—
Non-SAS, Non-Locking, Dark Gray	ATT200-1, ATT205-1, or ATT210-1	98908-1	—
Non-SAS, Non-Locking, Duck	ATT200-1, ATT205-1, or ATT210-1	98910-1	—
Non-SAS, Locking, Gray	ATT200-1, ATT205-1, or ATT210-1	98901-1	—
Non-SAS, Locking, Duck	ATT200-1, ATT205-1, or ATT210-1	98911-1	—
SAS, Non-Locking, Gray	ATT220-1	98920-1	—
SAS, Non-Locking, Dark Gray	ATT220-1	98928-1	—
SAS, Non-Locking, Duck	ATT220-1	98930-1	—
SAS, Locking, Gray	ATT220-1	98921-1	—
SAS, Locking, Duck	ATT220-1	98931-1	—

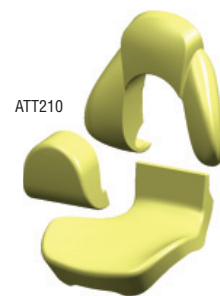

Molded Foam Packs

Centric II molded foam kits come in a variety of shapes to fit your individual styling needs. SAS and Non-SAS foam kits are used with their corresponding plastic kits above.

Description	Bulk Packaging	Aftermarket Packaging
Non-SAS Standard Foam Pack	ATT200-1	—
Non-SAS Flared Headrest Foam Pack	ATT205-1	—
Non-SAS Rounded Headrest Foam Pack	ATT210-1	—
SAS Standard Foam Pack	ATT220-1	—



For questions regarding Attwood's most up-to-date seating selections, or for assistance with your seating application, contact your Sales Representative or Attwood Customer Service (616.897.9241)

CENTRIC SAS™ SPORT SEATING

Centric SAS offers outstanding value and performance in a folding seat. It incorporates all of the ergonomically tuned comfort surfaces of the Centric seat with the added comfort of the SAS shock absorbing system. In rough seas and tight maneuvers, the side bolsters and SAS suspension help to keep the boater centered in the seat.

Lateral Support

By compressing the suspension system, the rider sits in the seat not on the seat.

Compact Turning Diameter

Centric SAS fits in confined cockpits with a 23" turning diameter.

Concealed Hinge

Patented pinch-proof hinge molded into the shell. Lock-Down detent secures seat in the down position at speeds up to 70 mph.

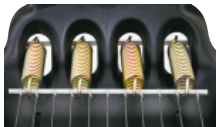

Spring Grid

Flexes with the coil springs and supports the seat foam. Continually adjusts for circulation and comfort.



Quad Spring Suspension

Provides comfort and 3" travel for shock absorption. Prevents rider from "bottoming out."

SAS SHOCK ABSORBING SYSTEM







Waterfall Front

Allows proper circulation at pressure points behind knees.

Centric Sas Fully Upholstered Seats

These attractively patterned High-Back Centric SAS spring suspension seats are trimmed out with deep-tuck upholstered backrest, molded polyurethane foam, and marine-grade vinyl upholstery. Seats include corrosion-resistant T-nuts for attachment to seat pedestals. Available with 4 base colors and 12 accent color options.

To Specify Base Color:

 Off-White Base Color = 98370 __-2	 Gray Base Color = 98372 __-2
 Tan Base Color = 98371 __-2	 Bright White Base Color = 98373 __-2

Specify one of the three base product numbers to indicate base color:

To Specify Accent Color:

Fill in blanks with the alpha code for accent color:

Example: Bright-White Base color with Red Accent = 98370RD-2

Description	Color	Bulk Packaging	Aftermarket Packaging
Centric SAS Fully Upholstered	Off-White	—	98370 __-2
Centric SAS Fully Upholstered	Tan	—	98371 __-2
Centric SAS Fully Upholstered	Gray	—	98372 __-2
Centric SAS Fully Upholstered	Bright White	—	98373 __-2

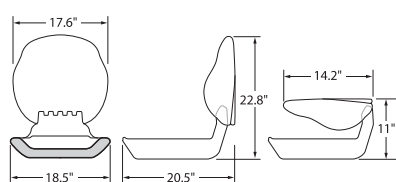

Mid-Back Dimensions

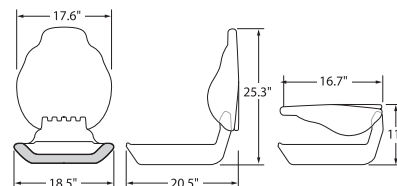

High-Back Dimensions



Accent Color

Base Color

Accent Colors

Description	Code
Burgundy	BG
Red	RD
Yellow	YE
Beige	BE
Tan	TN
Gray	GY
Smoke	SM
Black	BK
Blue	BL
Green	GN
Off-White	OW
Bright White	BW

CENTRIC SEATING

The popular Centric seat is a brilliant combination of style and sturdy support. The ergonomic contouring comforts and supports the spine and helps eliminate pressure points. The heavy-duty blow molded construction meets and exceeds ABYC H-31 impact standards.

Concealed Hinge

Patented pinch-proof hinge is molded into the shell. Lock-Down detent secures seat in the down position at speeds up to 70 mph.

Raised Seat Pan Back

Centric provides surprising support and comfort to your lower back and spine, unlike seats with traditional hinges that are open in the lower back.

Side Bolsters

Provide lateral support to help keep rider seated, even in rough seas and tight maneuvers.

Compact Turning Diameter

Centric fits in confined cockpits with a 23" turning diameter.



Recessed Underbody

A minor feature that helps hide the seat mount and slider, allowing for easy access to seat hardware adjustment handles and makes for a sleek interior. Fits all standard seat mounts and sliders.

Upholstery

Marine grade fabric is UV stable and weather resistant.



Centric Fully Upholstered Seats

These attractively patterned High-Back Centric seats are trimmed out with deep-tuck upholstered backrest, molded polyurethane foam, and marine-grade vinyl upholstery. Seats include corrosion-resistant T-nuts for attachment to seat pedestals. Available with 4 base colors and 12 accent color options.

To Specify Base Color:

Specify one of the three base product numbers to indicate base color:

 Off-White Base Color = 98380 __-2

 Gray Base Color = 98382 __-2

 Tan Base Color = 98381 __-2

 Bright White Base Color = 98383 __-2

To Specify Accent Color:

Fill in blanks with the alpha code for accent color:

Example: Bright-White Base color with Red Accent = 98380RD-2

Description	Color	Bulk Packaging	Aftermarket Packaging
Centric Fully Upholstered	Off-White	—	98380 __-2
Centric Fully Upholstered	Tan	—	98381 __-2
Centric Fully Upholstered	Gray	—	98382 __-2
Centric Fully Upholstered	Bright White	—	98383 __-2

Accent Colors

Description	Code
 Burgundy	BG
 Red	RD
 Yellow	YE
 Beige	BE
 Tan	TN
 Gray	GY
 Smoke	SM
 Black	BK
 Blue	BL
 Green	GN
 Off-White	OW
 Bright White	BW

CENTRIC CONTOUR SEATING

Centric Contour is the perfect solution for value-driven boat interiors.... and boaters who want attractive styling and comfort. These High-Back Centric seats are trimmed out with deep-tuck upholstered backrest, and new upholstery patterns. All upholstery is marine grade vinyl. Seats include corrosion-resistant T-nuts for attachment to seat pedestals.

Centric Contour Upholstered Seats

Description	Bulk Packaging	Aftermarket Packaging
White Marine Grade Vinyl Upholstery	—	98360-2
Tan/Beige Marine Grade Vinyl Upholstery	—	98361-2
Gray/Smoke Marine Grade Vinyl Upholstery	—	98362-2
Blue/White Marine Grade Vinyl Upholstery	—	98363-2
Mossy Oak Shadowgrass Camo Cordura Nylon Upholstery	—	98364-2
Red/White Marine Grade Vinyl Upholstery	—	98365-2
Blue/Gray Marine Grade Vinyl Upholstery	—	98366-2
Red/Gray Marine Grade Vinyl Upholstery	—	98367-2

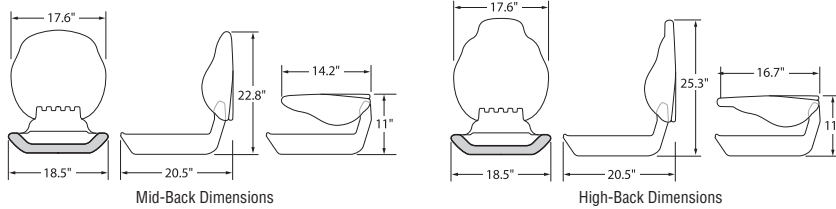

98365



98360



98363

Centric With Snap-On Removable Upholstered Pads

Enjoy the comfort of the Centric seat with snap-on removable upholstered pads. Seats include corrosion-resistant T-nuts for attachment to all standard-pattern seat pedestals.

Description	Bulk Packaging	Aftermarket Packaging
Centric Mid-Back, Black, with snap-on upholstered pads 1000 Denier Cordura, Shadow Grass Pattern	—	98304-2
Centric Mid-Back, White, with White vinyl snap-on upholstered pads	—	98350-2



98304



98350

CENTRIC SEAT COMPONENTS

With all of its features, Centric is surprisingly easy to upholster using our molded foam packs. Centric seat components consist of blow-molded fishing or helm seat cores, with SAS or non-SAS suspension system seat pan, injection molded upholstery inserts for the backrest and seat back hinge cover, injection molded vent plate for seat pan, and molded foam packs.

Seat Core Kits

Centric seat core kits include the seat pan with a choice of Mid-Back and High-Back backrest styles. Each seat includes a separate seatback insert to cover and protect the hinge. Insert can be applied and then upholstered over with the rest of the seatback or upholstered separate of the seatback as a means of providing an accent piece. Seat cores include corrosion-resistant T-nuts for attachment to seat pedestals.



Upholstery Inserts

The Upholstery Inserts speed up the upholstery of the backrest and provide an easy means of adding a stylish accent piece with deep-tuck seam. Insert posts snap securely into seat core using foolproof clips for quick, easy assembly.

Seat Pan Vent Plate

The Seat Pan Vent Plate provides a stylish cover for the back of the SAS shock absorbing seat pan.

Description	For Use with Foam Packs	Bulk Packaging	Aftermarket Packaging
SEAT CORES AND INSERTS			
SAS Mid-Back Core Kit	ATT001, ATT009, ATT010	98130-1	—
SAS High-Back Core Kit	ATT008, ATT010	98140-1	—
SAS Mid-Back II Core Kit	ATT016	98141-1	—
Mid-Back Core, Black	ATT001, ATT002, ATT007	98100-1	—
Mid-Back Core, White	ATT001, ATT002, ATT007	98200-1	—
High-Back Core, Black	ATT007, ATT008	98120-1	—
Mid-Back II Core, Black	ATT016	98121-1	—
Mid-Back Insert	ATT009	7009-1	—
High-Back Insert	ATT008	7006-1	—
Mid-Back II Insert	ATT016	98124	—
SAS SEAT PAN VENT PLATES			
Vent Plate, Black		7019-1	—
Vent Plate, White		7019W1	—

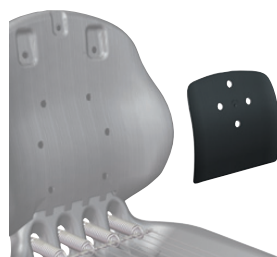

7019

7009

7006

98124

CENTRIC SEAT COMPONENTS

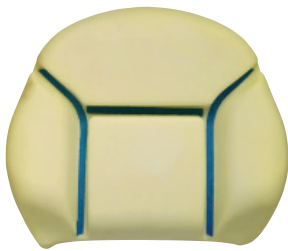

ATT001



ATT009



ATT008

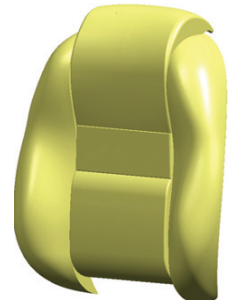

ATT016

Molded Foam Packs

Molded foam packs are contoured to enhance the ergonomic shape of Centric SAS's seat core for maximum comfort and style. Eliminates labor-intensive and costly cut foam and provides a consistent shape that improves the quality of the upholstered seat. Centric SAS foam packs are offered with a choice of integrated "hook and loop" or "onsert" upholstery methods.

Hook and Loop—Joins upholstery seam-to-foam to form a moderate tuck.

Onserts—provide a deep tucked seam depth by using a separate upholstered panel.

Description	For Use with Component	Bulk Packaging	Aftermarket Packaging
BACKREST FOAM PACKS			
Mid-Back, Hook & Loop	98130	ATT001	—
Mid-Back, w/Onsert	98130, 7009	ATT009	—
High-Back, w/Onsert	98140, 7006	ATT008	—
Mid-Back II Foam Pack	98141, 98121, 98124	ATT016	—
SEAT PAN FOAM PACKS			
SAS Pan, Hook & Loop	98130, 98140	ATT010	—
Sport Weight Hook & Loop	98100, 98200, 98120	ATT002	—
Luxury Weight Hook & Loop	98100, 98200, 98120	ATT007	—

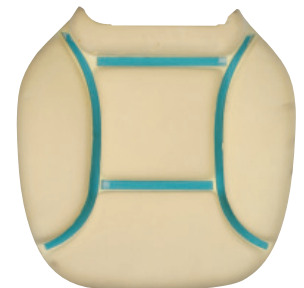

ATT010

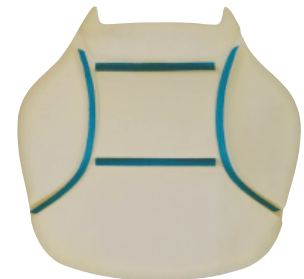

ATT002

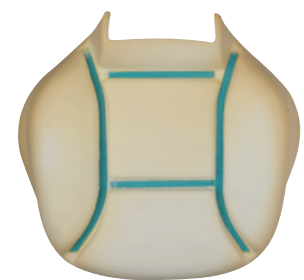

ATT007

For questions regarding Attwood's most up-to-date seating selections, or for assistance with your seating application, contact your Sales Representative or Attwood Customer Service (616.897.9241)

VENTURE FOLDING FISHING SEAT

The Venture folding fishing seat is designed to satisfy the widest possible range of boaters and boat builders. Mounts in any location on bass boats, aluminum fishing boats, fish'n ski, pontoon and deck boats. Its advanced styling distinguishes it from all other seats on the market, and its upholstery possibilities let you customize it for a unique look to any boat design, user preference or price point.

Ventilated

Seat back and pan are ventilated to allow pass-through of air and water for increased comfort.

Portability

Venture quickly folds away to allow more room for activity and fishing excitement. Then it can be easily removed and transported using the built-in carry handle.



Simple, Pinch-Proof Hinge and Lock

Push-button release automatically locks the seat back in upright sitting position or the folded position for transport.

Certified and Simple to Install

The Venture Upholstered Folding Seat meets all ABYC H-31 seating requirements. The seat bottom has molded-in T-Nuts in the universal 5" pattern. Requires only 4 bolts to fit on any standard pedestal.



97103



97104

Upholstered Folding Fish Seats

Description	Bulk Packaging	Aftermarket Packaging
SEAT WITH SLIP-ON UPHOLSTERED SEAT & BACK PADS		
White Seat Shell, White Marine Grade Vinyl Upholstery	—	97101-2
Medium Gray Seat Shell, Gray Marine Grade Vinyl Upholstery	—	97102-2
Taupe Seat Shell, Taupe Marine Grade Vinyl Upholstery	—	97103-2
Olive Seat Shell, ShadowGrass Cordura Nylon Upholstery	—	97104-2
SEAT WITH SLIP-ON UPHOLSTERED SEAT PAD ONLY		
White Seat Shell, White Marine Grade Vinyl Upholstery	—	97111-2
Medium Gray Seat Shell, Gray Marine Grade Vinyl Upholstery	—	97112-2
Taupe Seat Shell, Taupe Marine Grade Vinyl Upholstery	—	97113-2
Olive Seat Shell, ShadowGrass Cordura Nylon Upholstery	—	97114-2



97111



97100-029

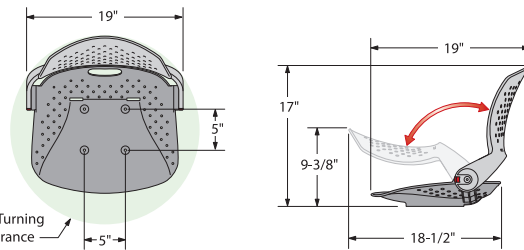

Seat Shell Only

Description	Bulk Packaging	Aftermarket Packaging
Shell Only, White	97100-001-1	97100-001-2
Shell Only, Off-White	97100-002-1	97100-002-2
Shell Only, Medium Gray	97100-005-1	97100-005-2
Shell Only, Dark Gray	97100-028-1	97100-028-2
Shell Only, Taupe	97100-029-1	97100-029-2
Shell Only, Olive	97100-006-1	97100-006-2

PROFORM SEATING

Molded-In Support

Designed into the contours of the seat back and pan, offering comfort with or without padding.

Molded-In Color

The high-impact polymer is strong and UV stable. Colors have been specially selected to coordinate with boat interiors, trim, carpet and vinyls

Upholstery

Marine grade fabric is UV stable and weather resistant.

Foam Padding

Minimized to reduce cost and water absorption yet provide comfort.

Molded-In Drain Holes

Eliminate standing water; no more "puddle sitting."



Pinch-Resistant Hinge

Strong enough to withstand impact.



Seat Back Lock

Secures backrest in down position; no more vinyl straps and snaps.

"Waterfall" Front Edge

Gently minimizes pressure behind the knees.

Curved Front Corners

Permit easy, comfortable movement when driving, fishing or relaxing.



7012-104

PROForm Seats With Upholstered Onserts

Available in a variety of colors, seats include backrest and seat pan onserts upholstered with marine grade vinyl or Cordura 1000 denier nylon that use 1" thick foam for comfort. Onserts are installed with corrosion-resistant screws. Seats include corrosion-resistant T-nuts for attachment to seat pedestals.



7012-101



7012-004



7012-504



7012-606

Description	Bulk Packaging	Aftermarket Packaging
SEATS WITH UPHOLSTERED ONSSERTS		
White PROForm Seat with White upholstered onserts	7012-101-1	7012-101-4
Light Gray PROForm Seat with Blue vinyl upholstered onserts	—	7012-004-4
Light Gray PROForm Seat with Red vinyl upholstered onserts	—	7012-104-4
Light Gray PROForm Seat with Gray vinyl upholstered onserts	7012-504-1	7012-504-4
Olive PROForm Seat with Woodland Camo Cordura nylon upholstered onserts	7012-606-1	7012-606-4
Olive PROForm Seat with Shadow Grass Cordura nylon upholstered onserts	7012-706-1	7012-706-4
SEATS WITH UPHOLSTERED ONSSERTS AND OUTER BACK PANEL – FOR MORE FINISHED LOOK		
White PROForm Seat and Outer Back Panel with White vinyl upholstered onserts	7022-101-1	—
Oyster PROForm Seat and Outer Back Panel, with Neutral vinyl upholstered onserts	7022-202-1	—



7012-202

